

Jordan Controls, Inc.

IM 0496-S

**MODEL PF-1010
POSITION SENSOR**

**MODEL PT-1000
POSITION TRANSMITTER**

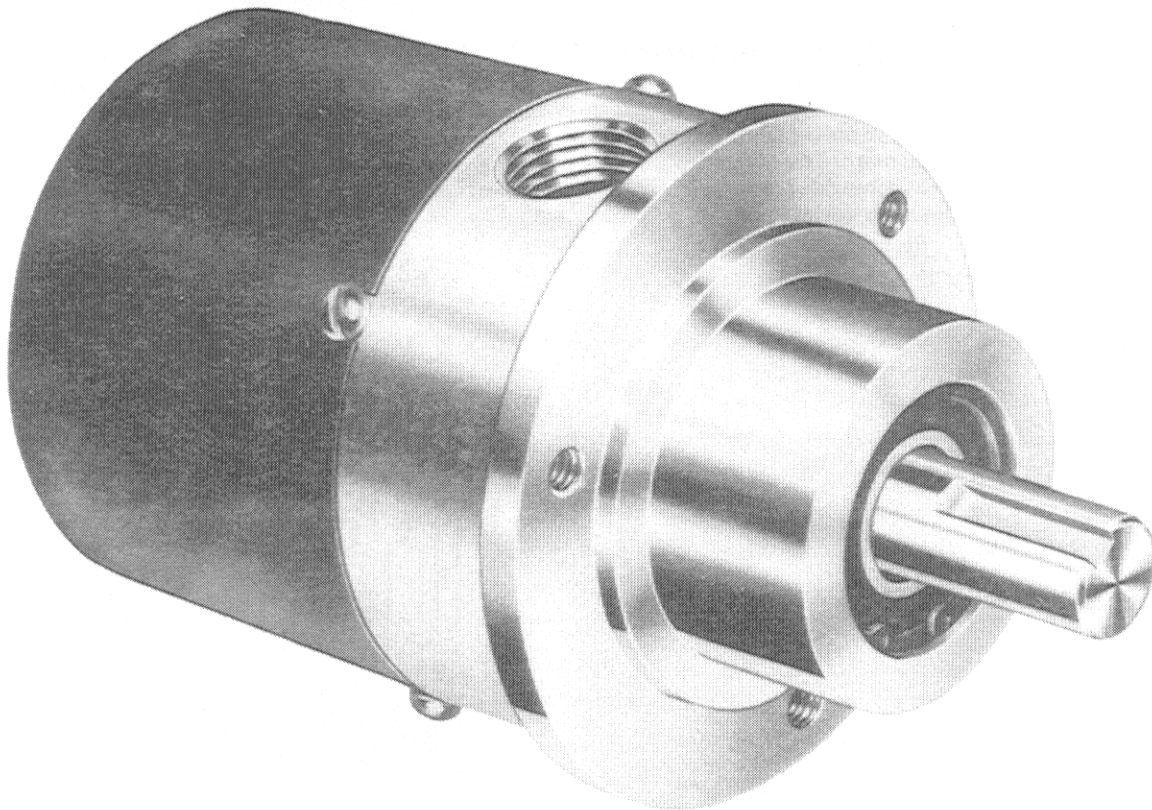

Jordan

CONTROLS

PF-1010

DESCRIPTION

The PF-1010 rotary position sensor is a ruggedly constructed sensor designed to convert mechanical input rotation to an electrical signal proportional to the input shaft position. The sensor may be equipped with a potentiometer and limit switches specified to actuate within the rotational range of the input shaft. The sensor has an input range of 58° to 460 turns depending on the gear ratio and potentiometer and/or limit switch arrangement used. The housing may be an inside industrial Nema 12, watertight Nema 4 or explosionproof Nema 7 & 9. The input shaft is made of stainless steel and is supported in ball bearings.

PT-1000

DESCRIPTION

The PT-1000 position transmitter is a PF-1010 rotary position sensor with a 1000 ohm potentiometer and an EC-10649 2 wire transmitter mounted inside of the sensor. The 2 wire transmitter converts the linear movement of the potentiometer to a 4-20 ma output signal. All the parts and gear ratios of the PF-1010 are compatible with the PT-1000.

MOUNTING

INSTALLATION

The PF-1010 and PT-1000 may be mounted in any desired position. While some installations use the 3.625 Dia. lip as a servo type mount with lip clamps most installers use the 3 hole face mount. When using the 3 hole face mount tighten each bolt evenly to approximately 8 foot lbs. The bolts should be grade 5 or better.

The input shaft has a diameter of .6250 inches and is slotted to accept a .187 sq. key x .70 long. The device you attach to the shaft should slide on and not be forced onto the shaft. If the shaft is to be "in line coupled" to another shaft it is best to use a flexible coupling to prevent excessive side loading due to shaft misalignment. The conduit entry should be kept plugged until ready for wiring and the cover should be put in place to protect the internals of the unit.

WIRING

INSTALLATION

Prior to wiring the unit locate the internal wiring print which was shipped with the order. Check the wiring print for compatibility with your system wiring prints.

Access to the wiring terminals is obtained by removing the cover. Nema 12 units use a slip-on cover retained with four (4) slot head screws around the outside of the unit. Nema 4, 7 and 9 units use a screw-on cover. Turning the cover counter clockwise will allow removal. The screw threads are lightly lubricated with grease to prevent seizing. Keep the threads clean of all dirt.

The unit is equipped with a ½ NPT conduit entry. The conduit must be sealed to prevent water from entering the unit.

INSTALLATION MOUNTING DIMENSIONS

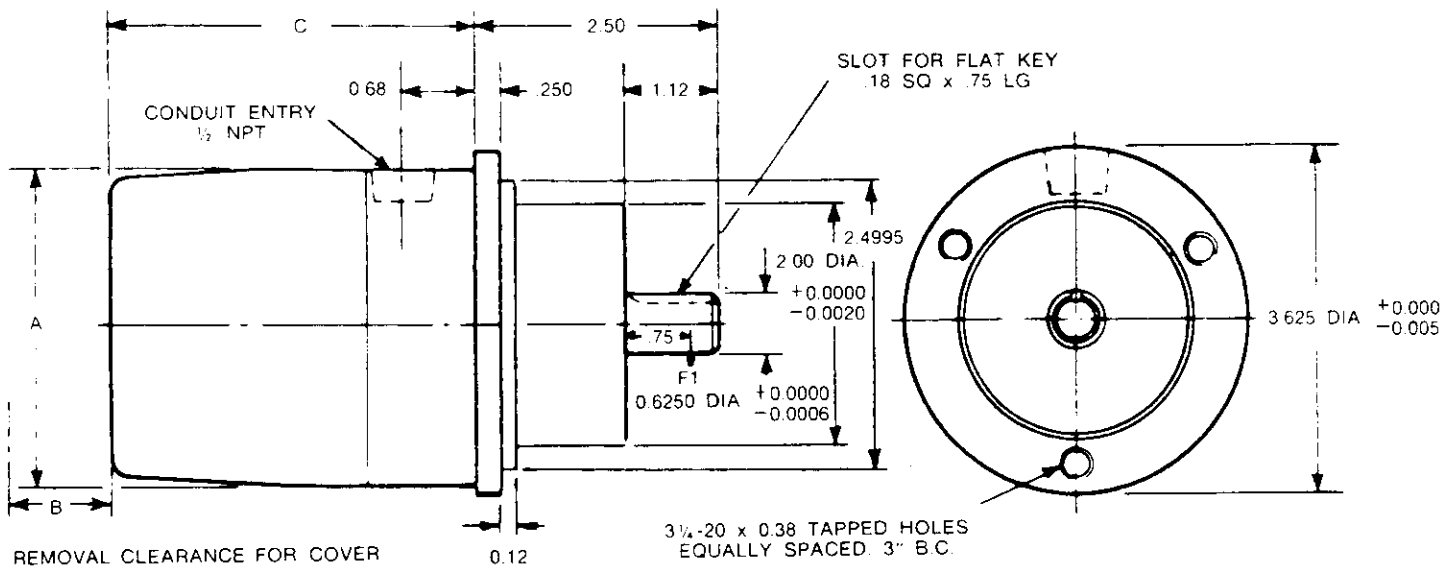

BASIC UNIT	A	B (STD)	B (LIMIT SWITCH OPTION)	C (STD)	C (LIMIT SWITCH OPTION)
PF-1010-D	3.38 DIA (85.85 mm)	2.50 (63.5 mm)	4.50 (114.3 mm)	3.75 (95.25 mm)	5.75 (146.05 mm)
PF-1010-E	3.50 DIA (88.9 mm)	2.81 (71.37 mm)	4.81 (122.17 mm)	4.06 (103.12 mm)	6.06 (153.92 mm)
PF-1010-X	3.50 DIA (88.9 mm)	2.81 (71.37 mm)	4.81 (122.17 mm)	4.06 (103.12 mm)	6.06 (153.92 mm)

BASIC UNIT	A	B (STD)	C (STD)
PT-1000-D	3.38 DIA (85.85 mm)	4.50 (114.3 mm)	5.75 (146.05 mm)
PT-1000-E	3.50 DIA (88.9 mm)	4.81 (122.17 mm)	6.06 (153.92 mm)
PT-1000-X	3.50 DIA (88.9 mm)	4.81 (122.17 mm)	6.06 (153.92 mm)

MAXIMUM INPUT TORQUE REQUIRED = 3 IN. LBS.
 F1 = MAXIMUM OVERHUNG OR SIDE LOAD AT 50 RPM = 150 LBS.

**PF-1010 PT-1000
WATERTIGHT
NEMA 4**

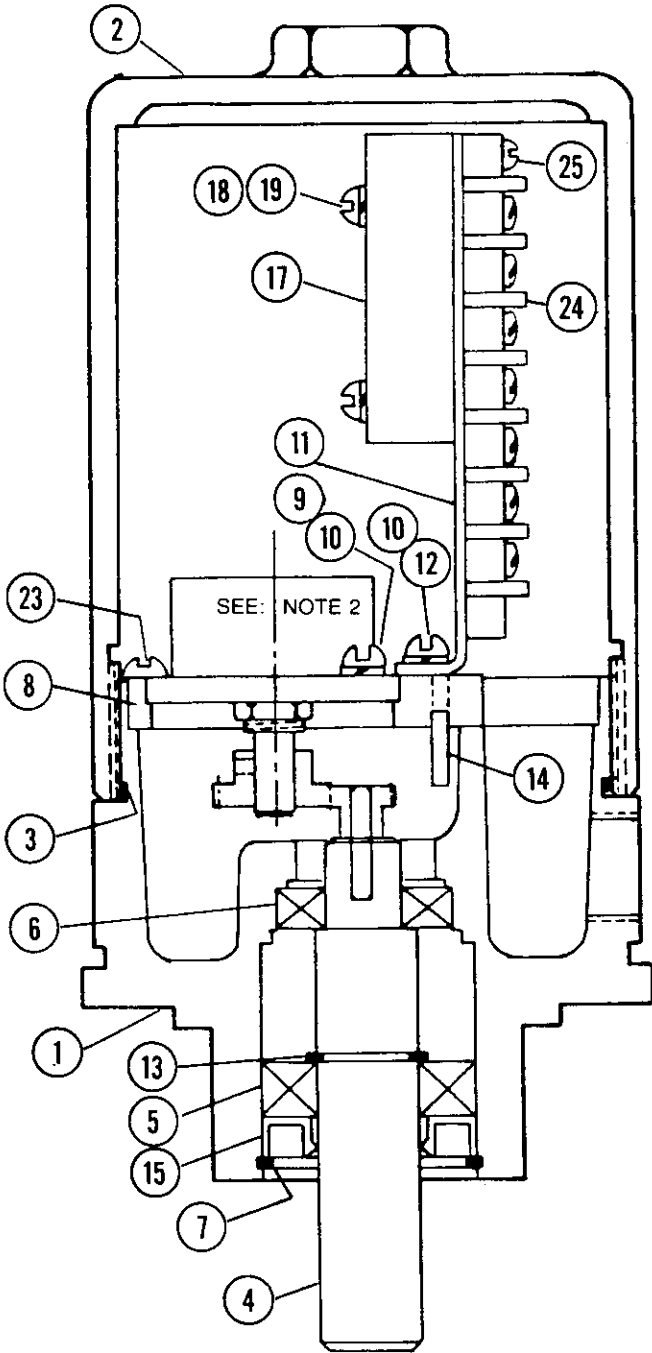

ITEM	DESCRIPTION	PART NUMBER	QTY.
1	Housing Base	60C-007164-001	1
2	Cover (long) Note 1	60A-007372-001	1
2	Cover (short) Note 1	60A-007371-001	1
3	"O" Ring	74B-010957-151	1
4	Input Shaft	62A-012432-001	1
5	Bearing	17B-003813-010	1
6	Bearing	17B-003813-011	1
7	Ret. Ring 5100-137	58B-014184-137	1
8	Plate	60A-007150-001	1
9	Screw 8-32 x .62	54A-015033-062	2
10	#8 Lockwasher	56A-015190-002	4
11	Brkt. (Long PF-1010)	13A-007169-001	1
11	Brkt. PT-1000	13A-007169-002	1
11	Brkt. (short — PF-1010)	13A-007103-001	1
12	Screw 8-32 x .32	54A-015033-031	2
13	Ret. Ring 5100-62	58B-014183-062	1
14	Pin .125 x .50	57A-015186-050	1
15	Seal	19B-003815-011	1
17	PT-1000 Xmitter	70A-019948-001	1
18	Screw 6-32 x .75	54A-015023-075	2
19	#6 Lockwasher	56A-015180-002	2
23	Screw 8-32 x .25	54A-015032-025	3
24	Terminals 3 Pin	43B-003888-103	1
24	Terminals 5 Pin	43B-003888-105	1
24	Terminals 7 Pin	43B-003888-107	1
25	Screw 6-32 x .38	54A-015023-038	2

NOTE 1: Long cover used on PF-1010 with potentiometer and limit switch feedback, always used on PT-1000. Short cover used on PF-1010 with potentiometer only — no switches.

NOTE 2: Feedback and gearing shown for reference only. See gear chart and feedback parts list.

**PF-1010/PT-1000
EXPLOSION PROOF
NEMA 7 & 9**

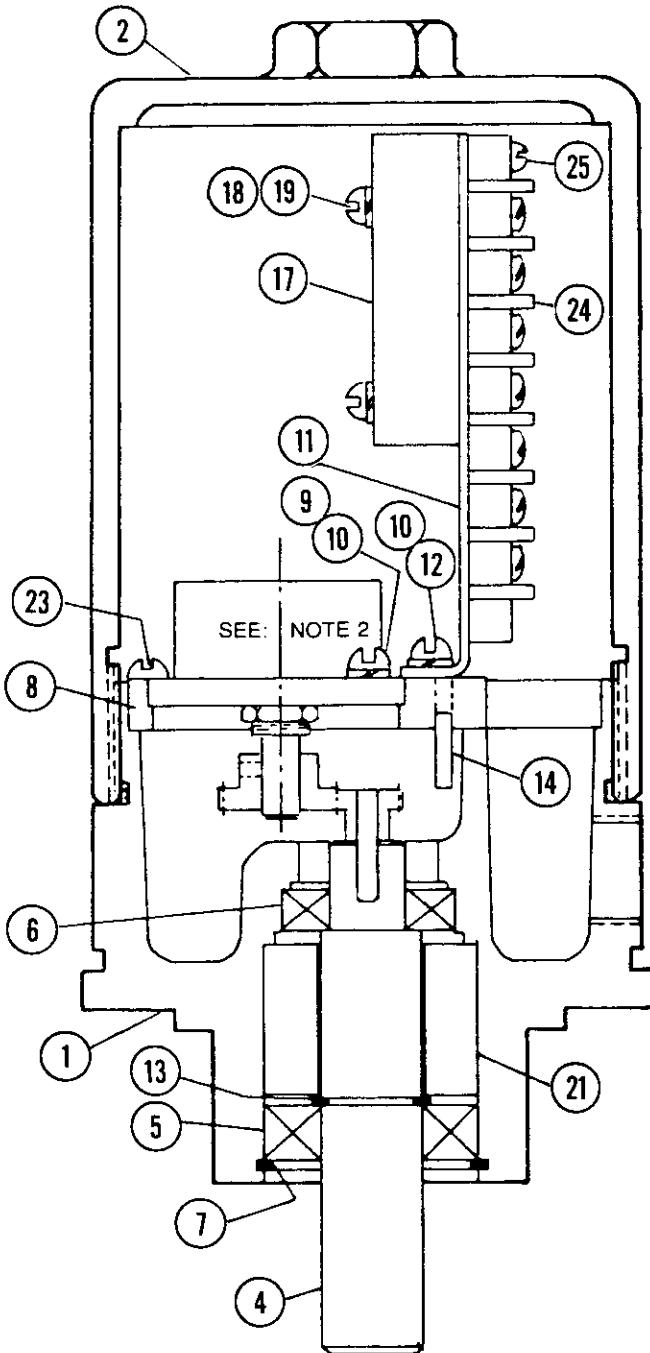

ITEM	DESCRIPTION	PART NUMBER	QTY.
1	Housing Base	60C-007164-001	1
2	Cover (long) Note 1	60A-007372-001	1
2	Cover (short) Note 1	60A-007371-001	1
4	Input Shaft	62A-007151-001	1
5	Bearing	17B-003813-010	1
6	Bearing	17B-003813-011	1
7	Ret. Ring 5000-137	58B-014184-137	1
8	Plate	60A-007150-001	1
9	Screw 8-32 x .62	54A-015033-062	2
10	#8 Lockwasher	56A-015190-002	4
11	Brkt. Long	13A-007169-002	1
11	Brkt. Short	13A-007103-001	1
12	Screw 8-32 x .31	54A-015033-031	2
13	Ret. Ring 5100-62	58B-014183-062	1
14	Pin .125 x .50	57A-015186-050	1
17	PT-1000 Xmitter	70A-019948-001	1
18	Screw 6-32 x .75	54A-015023-075	2
19	#6 Lockwasher	56A-015180-002	2
21	Spacer	61A-007159-001	1
23	Screw 8-32 x .25	54A-015032-025	3
24	Terminals 3 Pin	43B-003888-103	1
24	Terminals 5 Pin	43B-003888-105	1
24	Terminals 7 Pin	43B-003888-107	1
25	Screw 6-32 x .38	54A-015023-038	2

NOTE 1: Long cover used on PF-1010 with potentiometer and limit switch feedback, always used on PT-1000. Short cover used on PF-1010 with potentiometer only — no switches.

NOTE 2: Feedback and gearing shown for reference only. See gear chart and feedback parts list.

**PF-1010 PT-1000
INSIDE INDUSTRIALS
NEMA 12**

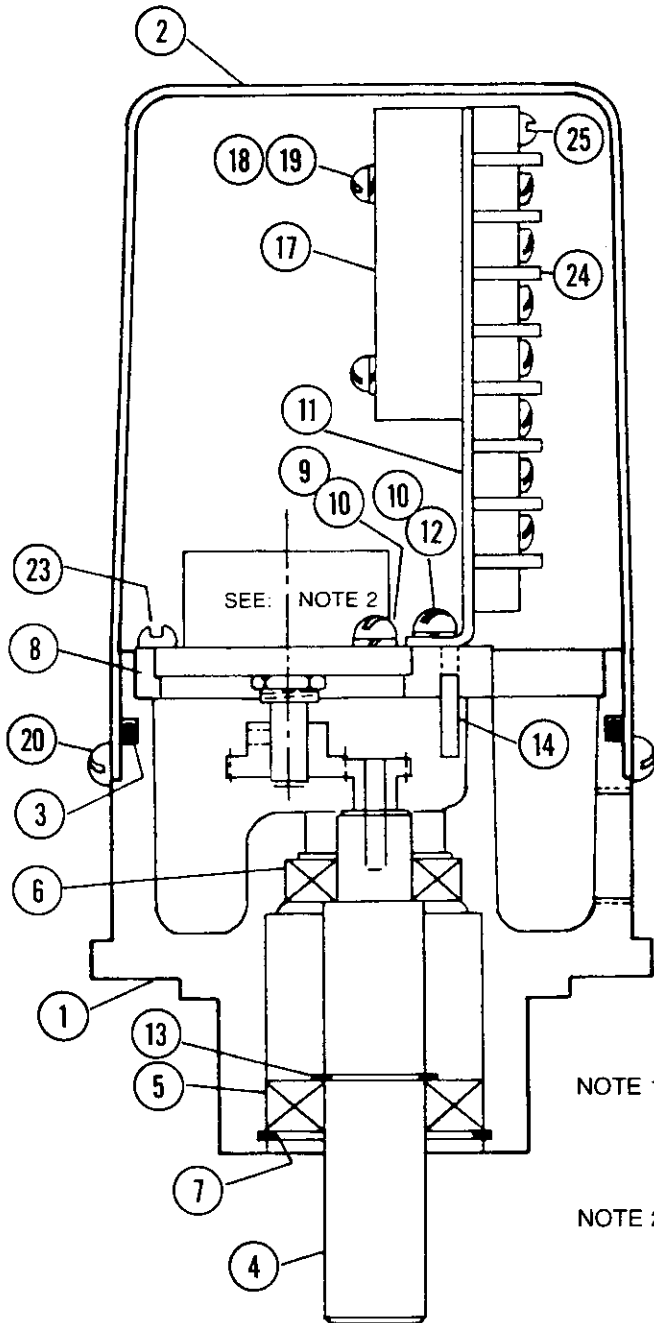

ITEM	DESCRIPTION	PART NUMBER	QTY.
1	Housing Base	60C-007148-001	1
2	Cover (long) Note 1	11A-003712-001	1
2	Cover (short) Note 1	11A-001383-001	1
3	"O" Ring	74B-004108-003	1
4	Input Shaft	62A-007151-001	1
5	Bearing	17B-003813-010	1
6	Bearing	17B-003813-011	1
7	Ret. Ring 5000-137	58B-014184-137	1
8	Plate	60A-007150-001	1
9	Screw 8-32 x .62	54A-015033-062	2
10	#8 Lockwasher	56A-015190-002	4
11	Brkt. Long PF-1010	13A-007169-001	1
11	Brkt. PT-1000	13A-007169-002	1
11	Brkt. Short PF-1010	13A-007103-001	1
12	Screw 8-32 x .32	54A-015033-031	1
13	Ret. Ring 5100-62	58B-014183-062	1
14	Pin .125 x .50	57A-015186-050	1
17	PT-1000 Xmitter	70A-019948-001	1
18	Screw 6-32 x .75	54A-015023-075	2
19	#6 Lockwasher	56A-015180-002	2
20	Screw 8-32 x .25	54A-015033-025	4
23	Screw 8-32 x .25	54A-015032-025	3
24	Terminal 3 Pin	43B-003888-103	1
24	Terminal 5 Pin	43B-003888-105	1
24	Terminal 7 Pin	43B-003888-107	1
25	Screw 6-32 x .38	54A-015023-038	2

NOTE 1: Long cover used on PF-1010 with potentiometer and limit switch feedback, always used on PT-1000. Short cover used on PF-1010 with potentiometer only — no switches.

NOTE 2: Feedback and gearing shown for reference only. See gear chart and feedback parts list.

FEEDBACK GEARING

The PF-1010 and PT-1000 can be built with any of 18 different gear ratios listed on the gear charts. The chart labeled "GEARING/% POTENTIOMETER USAGE" lists the gear ratios, number of teeth on each gear and the required input shaft rotation for 60%, 90% and 100% usage of the potentiometer element. For most installations the gear ratio is selected so that as the input shaft is rotated from one extreme to the other the potentiometer will rotate a minimum of 60% of its full travel to a maximum of 90%. It

is not recommended that you use more than 90% or less than 60% of the available 100% input turns.

Using 100% of the potentiometer range will cause a 10 turn potentiometer to hit its end stops and break. In using a 348° potentiometer the wiper arm might lose contact with the end of the element causing a loss of signal. If cam switches are used the cams will overlap activating both the CW and CCW switches at the same time.

GEARING/% POTENTIOMETER USAGE

RATIO	GEARS			INPUT TURNS			INPUT TURNS		
	No. of teeth			348° 1 turn pot.			10 turn pot.		
	C	B	A	60%	90%	100%	60%	90%	100%
.279:1	55	25 57	35	58°	87°	96°	1.16	2.51	2.79
.429:1	56	— —	24	90°	134°	149°	2.57	3.86	4.29
.600:1	50	— —	30	125°	188°	208°	3.61	5.40	6.0
1:1	40	— —	40	209°	313°	348°	6.0	9.0	10.0
1.22:1	36	— —	44	255°	382°	1.17	7.32	10.98	12.2
2.33:1	24	— —	56	1.35	2.03	2.25	13.98	20.97	23.3
3:1	20	— —	60	1.74	2.61	2.89	18.0	27.0	30.0
3.44:1	18	— —	62	1.99	2.99	3.32	20.64	30.46	34.4
4.72:1	14	— —	66	2.74	4.11	4.56	28.32	42.48	47.2
5.66:1	12	— —	68	3.28	4.92	5.47	33.96	50.94	56.6
7:1	10	— —	70	4.06	6.09	6.76	42.00	63.00	70.00
11.55:1	19	61 20	72	6.70	10.05	11.16	69.30	103.95	115.5
14.4:1	16	64 20	72	8.35	12.53	13.91	86.40	129.60	144.0
16.9:1	14	66 20	72	9.80	14.70	16.33	101.4	152.1	169.0
20:1	20	60 12	80	11.59	17.39	19.33	120.0	180.0	200.0
26.7:1	16	64 12	80	15.47	23.23	25.80	160.2	240.3	267.0
31.4:1	14	66 12	80	18.23	27.32	30.32	188.4	282.6	314.0
46.6:1	10	70 12	80	27.07	40.54	45.0	279.6	419.4	466.0

FEEDBACK GEARING

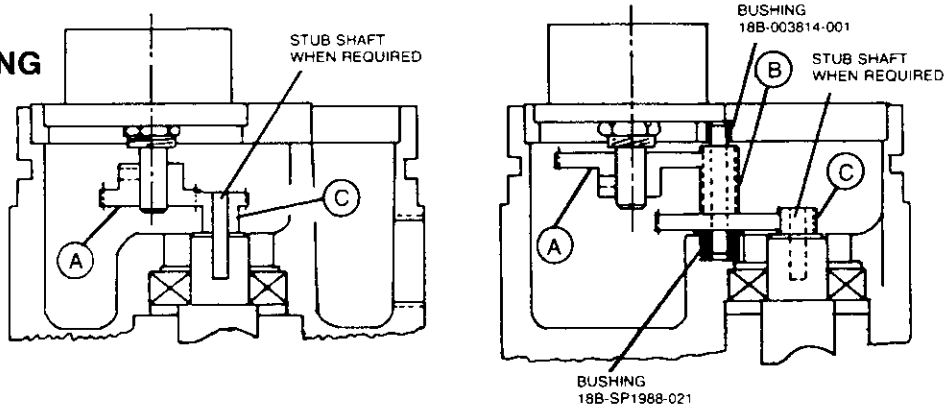

RATIO	GEAR A	GEAR ASSEMBLY B	GEAR C	STUB SHAFT 62A-007370-001	
				YES	NO
.279:1	16B-003811-162	65A-009396-001	16B-003811-163	X	
.429:1	16B-003811-140	not used	16B-003811-160	X	
.600:1	16B-003811-143	not used	16B-003811-151	X	
1:1	16B-003811-037	not used	16B-003811-060	X	
1.22:1	16B-003811-040	not used	16B-003811-150	X	
2.33:1	16B-003811-055	not used	16B-003811-017	X	
3:1	16B-003811-059	not used	16B-003811-014	X	
3.44:1	16B-003811-063	not used	16B-003811-004	X	
4.72:1	16B-003811-067	not used	16A-007359-001	X	
5.66:1	16B-003811-075	not used	16A-007829-001		X
7:1	16B-003811-083	not used	16A-007358-001		X
11.55:1	16B-003811-072	65A-007369-001	16B-003811-134	X	
14.4:1	16B-003811-072	65A-007368-001	16A-007360-001		X
16.9:1	16B-003811-072	65A-007367-001	16A-007359-001		X
20:1	16B-003811-079	65A-007366-001	16B-003811-014	X	
26.7:1	16B-003811-079	65A-007365-001	16A-007360-001		X
31.4:1	16B-003811-079	65A-007364-001	16A-007359-001		X
46.6:1	16B-003811-079	65A-007363-001	16A-007358-001	X	

NOTE 1: Stub shaft is pressed into hole in input shaft. Apply Loctite RC/601 to stub prior to inserting.

NOTE 2: Gear "C" may be held to stub shaft with set screws, roll pin or Loctite depending on gear size. Where no stub shaft is used, gear "C" and stub are one piece.

LUBRICATION: AMOCO-RYKON PREMIUM GREASE NO. 2 or SHELL-DARINA EP-O

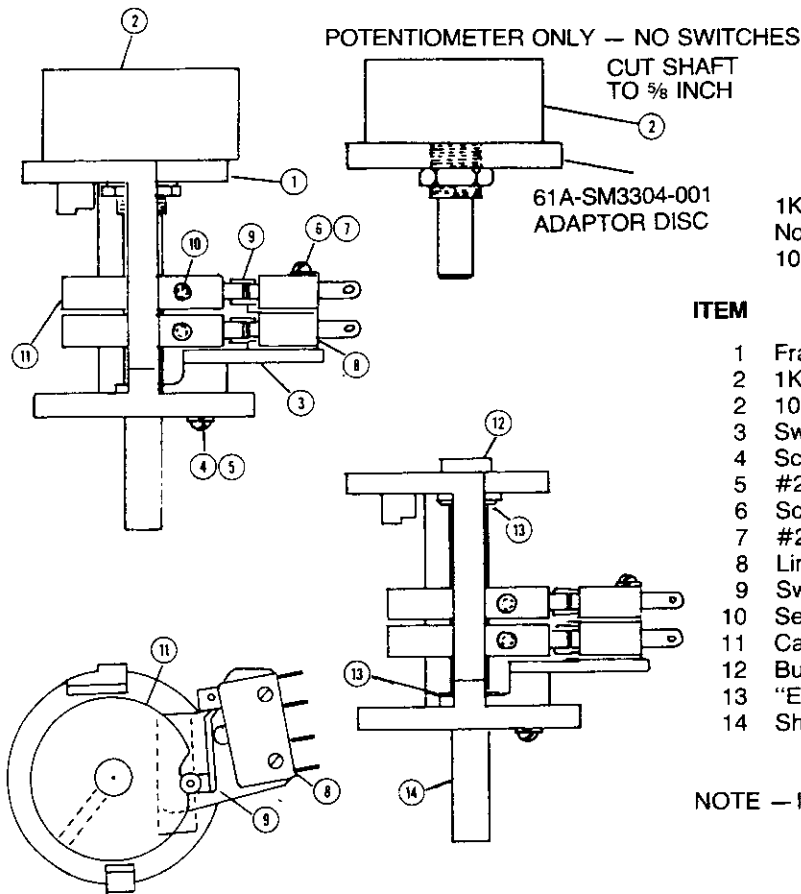

CAM OPERATED FEEDBACK ASSEMBLY

DESCRIPTION	PART NUMBER
1K pot & 2 Switches	68B-018200-001
No pot - 2 Switches	68B-018200-006
10K pot & 2 Switches	68B-018200-017

ITEM	DESCRIPTION	PART NUMBER	QTY.
1	Frame	14C-008600-001	1
2	1K Pot.	34A-015848-001	1
2	10K Pot.	34B-100032-014	1
3	Switch MTG. Plate	13A-010187-001	1
4	Screw 2-56 x .50 LG.	54A-015003-050	2
5	#2 Lockwasher	56A-015160-002	2
6	Screw 2-56 x .62 LG.	54A-015003-062	2
7	#2 Lockwasher	56A-015160-002	2
8	Limit Switch (SPDT)	46B-004053-405	2
9	Switch Actuator	46B-004053-406	2
10	Set Screw 8-32 x .38 LG.	54A-015037-038	2
11	Cam	14A-SM2341-001	2
12	Bushing	18B-SP1988-006	1
13	"E" Ring	#5133-25	2
14	Shaft (no pot)	62A-005942-001	1

NOTE — Items 12, 13, 14 only used on feedbacks without pot.

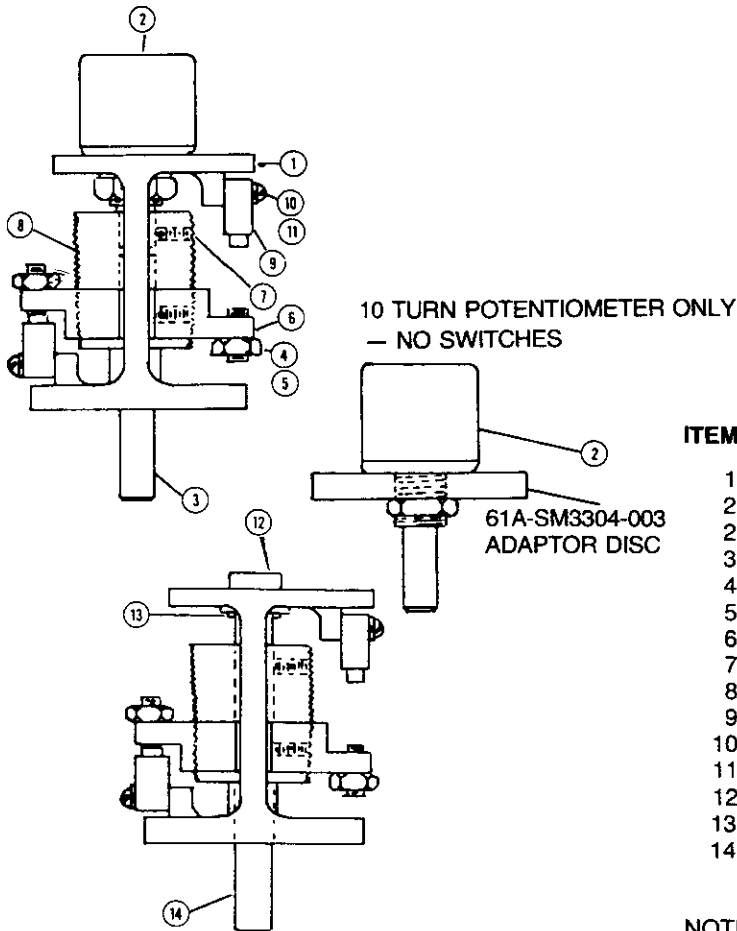

MULTI-TURN FEEDBACK ASSEMBLY

MULTI-TURN FEEDBACK ASSEMBLY

DESCRIPTION	PART NUMBER
1K Pot & 2 Switches	68B-006800-001
10K Pot & 2 Switches	68B-006800-002
No Pot - 2 Switches	68B-006800-003

ITEM	DESCRIPTION	PART NUMBER	QTY.
1	Frame	14C-008600-001	1
2	1K 10 Turn Pot.	34B-100033-001	1
2	10K 10 Turn Pot.	34B-100033-002	1
3	Shaft	62A-006806-001	1
4	Nut 8-32	55A-015038-001	2
5	Set Screw 8-32 x .38	54A-015037-038	2
6	Traveling Nut	14B-008602-001	1
7	Set Screw 8-32 x .25	54A-015037-025	2
8	Multi-Turn Screw	61A-006804-001	1
9	Limit Switch	46B-004053-409	2
10	Screw 2-56 x .38	54A-015003-038	4
11	#2 Lockwasher	56A-015160-002	4
12	Bushing	18B-SP1988-006	1
13	"E" Ring	#5133-25	1
14	Shaft	62A-005942-001	1

NOTE — Items 12, 13, 14 only used on feedbacks without pot.

PF-1010 Feedback Alignment

1. Locate the wiring print supplied with the unit.
2. If power is applied turn it off or use caution to prevent electrical shock.
3. Remove the access cover.
4. With the input shaft coupled to the driving device, rotate or cause the driving device to rotate the input shaft in the zero or minimum travel direction. While rotating observe the rotation direction of the potentiometer or limit switch shaft. Once you have established the direction of feedback rotation, stop rotating.
5. Remove 3 screws (item 23) which retain the feedback assembly.
6. Remove the feedback assembly from the unit.
7. Continue rotating the driving device to its full minimum position.
8. Holding the feedback assembly in one hand rotate the potentiometer shaft or limit switch shaft in the direction it was rotating in step 4. If the feedback has limit switches, rotate until the proper switch is tripped. If the

feedback is a potentiometer only, rotate the shaft until the wiper arm is 50 ohms off the zero end on a 1,000 ohm potentiometer or 500 ohms off the end on a 10,000 ohm potentiometer.

9. Insert the feedback into its mounting hole and tighten with the 3 screws removed in step 5.
10. If the feedback assembly is a potentiometer with limit switches, the potentiometer must now be set for 50 or 500 ohms as in step 8. Do this by loosening the potentiometer nut and rotating the body of the potentiometer. After setting tighten the nut.
11. Rotate the driving device in the increase direction and back to the minimum position. Re-check the limit switch setting and potentiometer position. Adjust if needed.
12. Rotate the driving device in the increase direction to the maximum travel position. Adjust the maximum position limit switch to trip at the maximum travel position.
13. Run the system and check limit switch wiring for proper operation.

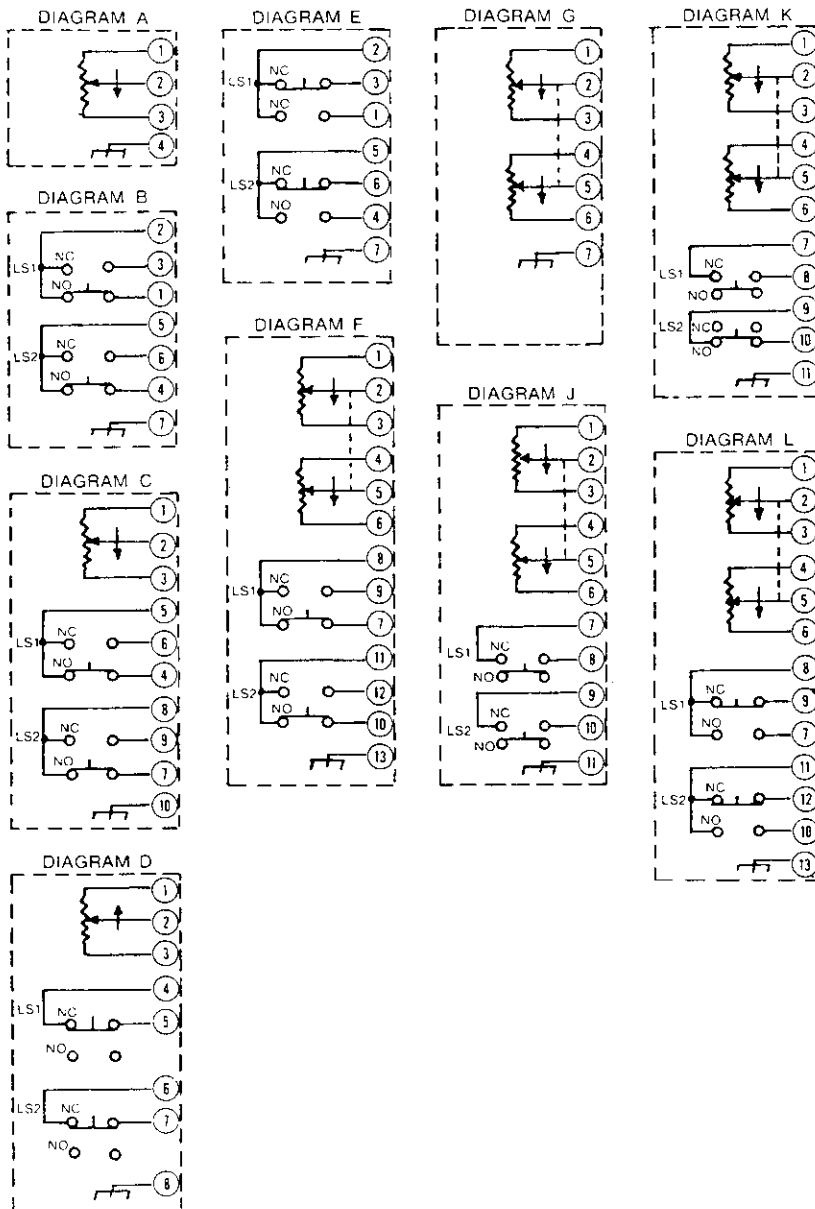

PF-1010

WIRING DIAGRAMS

DIAG.	FEEDBACK DESCRIPTION
A	potentiometer only
B	2 limit switches only cam activated
C	potentiometer 2 limit switches cam activated
D	multi-turn potentiometer 2 limit switches
E	2 limit switches multi-turn assembly
F	tandem potentiometer 2 limit switches cam activated
G	tandem potentiometers single or 10 turn
J	tandem potentiometer 2 limit switches — switches close at travel limits — cam activated
K	tandem potentiometer 2 limit switches — 1 NC, 1 NO wired out cam activated
L	tandem potentiometer 2 limit switches multi-turn assembly

NOTES:

1. Switches shown at mid-travel position. (Not at either limit)
2. LS1 operates at CW limit. (CW rotation of input shaft as viewed from shaft end)
3. LS2 operates at CCW limit. (CCW rotation of input shaft as viewed from shaft end)
4. Symbol indicates direction of potentiometer wiper travel for CW rotation of input shaft, viewed from shaft end.

PT-1000

Transmitter Alignment

1. Potentiometer and switch alignment.

Follow the feedback alignment for the PF-1010. The PT-1000 will always have a 1000 ohm potentiometer in the feedback assembly. When adjusting the potentiometer for 50 ohms at the minimum position remove the blue and yellow wires from the transmitter at terminals 3 and 5. As the PT-1000 is shipped from the factory turning the input shaft CW (looking at the shaft end) will cause an increasing output of the 4-20 ma signal. The potentiometer is set for 50 ohms between terminals 3 and 4 at the CCW limit of input shaft rotation. If it is desired that the current signal increase for CCW rotation, it will be necessary to interchange the blue and yellow wires at terminals 3 and 5. It will also be necessary to adjust the potentiometer for 50 ohms between terminals 4 and 5 with the input shaft at its CW limit of rotation.

2. Calibration

For the unit to function properly the 4 ma end of the feedback potentiometer must be preset to 50 ohms. This will insure linearity across the active region of the

feedback potentiometer. Both the RANGE and ELEVATION adjustments interact. (Range affects Elevation more than the other way around.) The Elevation adjustment is used to set the 4 ma point. The Range adjustment is used to set the 20 ma point for a span of 16 ma.

- Position the input shaft to the position where 4 ma output PT-1000 is desired.
- Confirm that the potentiometer resistance is approximately 50 ohms.
- Adjust ELEVATION for 4 ma.
- Position the input shaft to the position where 20 ma output of the PT-1000 is desired.
- Adjust RANGE for 20 ma. (A span of 16 ma)
- Repeat steps a,c,d & e until no further adjustments are necessary as RANGE and ELEVATION do interact.
- If the transmitter has the outputs reversed, 4 ma where 20 ma is desired and 20 ma where 4 ma is desired, reverse the blue and yellow wires and return to step a.

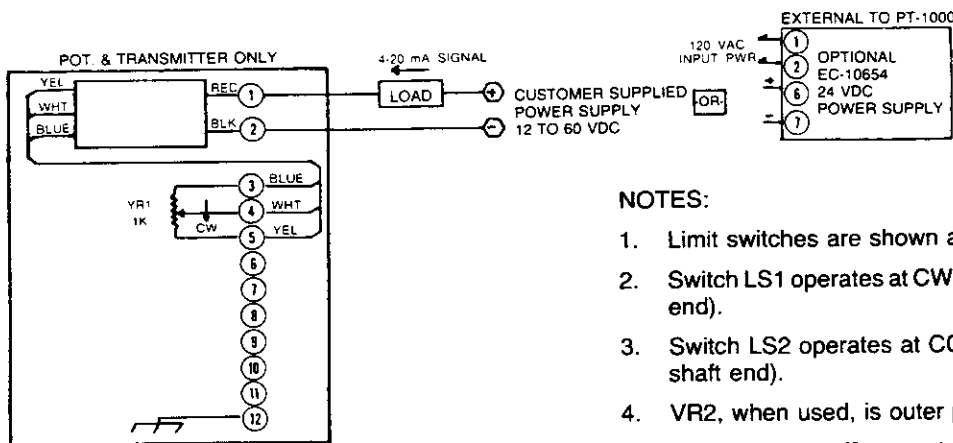

**PT-1000
4-20 mA TRANSMITTER
WIRING DIAGRAMS**

NOTES:

- Limit switches are shown at mid-travel (not at either limit).
- Switch LS1 operates at CW end of shaft rotation (as viewed from shaft end).
- Switch LS2 operates at CCW end of shaft rotation (as viewed from shaft end).
- VR2, when used, is outer pot.
- CW rotation of PT-1010 shaft (as viewed from shaft end) will result in the pot wiper (s) moving in the direction as indicated by the arrow(s). This will result in an increasing output of the 4-20 mA signal.
- If it is desired that the current signal increase for CCW shaft rotation, it will be necessary to interchange the blue and yellow wires at terminals 3 and 5.
- Supply voltage is not to exceed 60 VDC.
- The maximum load through which the 4-20 mA signal can be driven may be determined by the following formula:

$$\text{Max. Resistance} = \frac{\text{supply voltage} - 12\text{V}}{\text{maximum current}}$$

Example:

$$\text{Max. Rest.} = \frac{24\text{V} - 12\text{V}}{20\text{mA}} = 600\text{ ohm}$$

2 LIMIT SWITCHES
CAM ARRANGEMENT

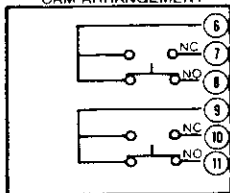

2 LIMIT SWITCHES
MULTI-TURN ARRANGEMENT

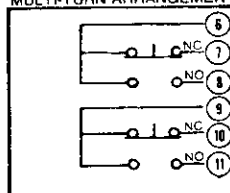

ADDITIONAL POT.

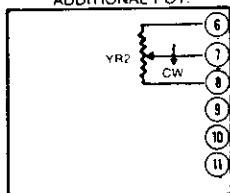

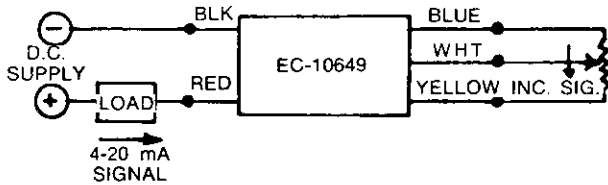
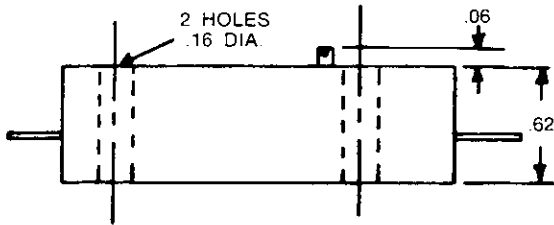
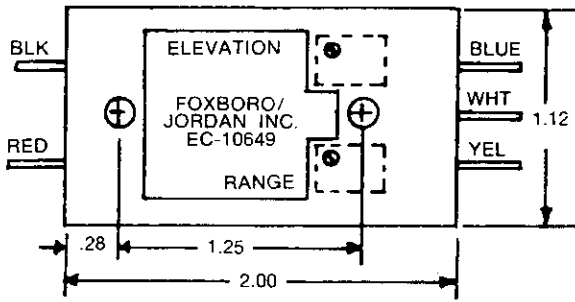

**4-20 mA. 2 WIRE TRANSMITTER
MODEL EC-10659
PART NO. 70A-019948-001**

The EC-10649 (1000 Ohm-input, 4-20 mA-output) 2-wire transmitter modulates the current on a direct current supply line proportional to the input resistance. It is powered by a 12V to 60V DC unregulated power supply line which is modulated from 4 mA to 20 mA proportional to the resistance of the input. Elevation and range adjustments are accessible on the top of the unit.

Output Span	4-20 mA prop. to full scale input.
Output Linearity*	Within 0.1% full scale output.
Input Resistance	1000 ohm ± 10%
Power Supply Voltage	12V DC — 60V DC unregulated.
Maximum Loop Res.	Supply Voltage — 12V = R. MAX.

$$\text{Example: } \frac{50V-12V}{.020A} = 1900 \text{ ohm}$$

Temperature Range	0°C - 52°C/32°F - 151°F
Line Voltage Effect	0.1% output variation with 45V power supply variation.
Temperature Effect	0.05% output variation per °C
Grounding	Input or output grounding is acceptable but not both .

*Referenced to linearity of input

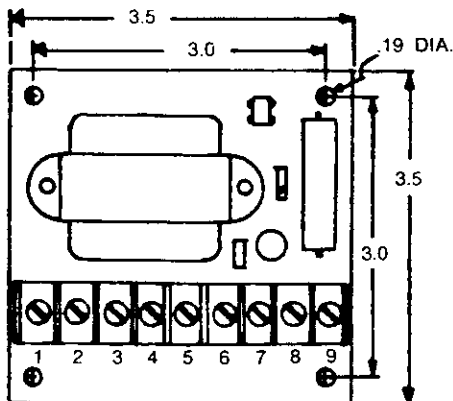
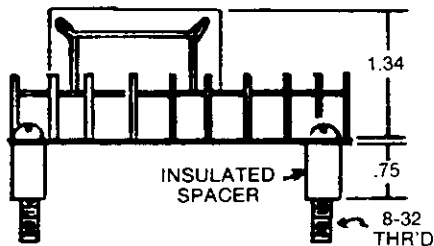

**24 VDC POWER SUPPLY
MODEL EC-10654
PART NO. 70C-020046-001**

The EC-10654 is a panel mounted 24 VDC power supply designed for use with the EC-10649 transmitter

INPUT:	120 VAC
	.020 AMPS MAX.
OUTPUT:	24V DC ± 1 VDC
	50 mA
MAX. TEMPERATURE	55°C AMBIENT
INPUT FUSING BY CUSTOMER	.25 amp

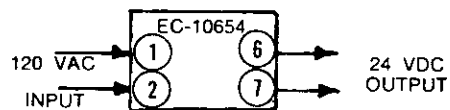

POTENTIOMETER REPLACEMENT

1. Disconnect Power.
2. Remove Cover.
3. Remove 3 Feedback Mounting Screws (Item 23).
4. Remove Feedback Assembly From Unit.
5. Go To A, B or C.

A. POTENTIOMETER ONLY — NO SWITCHES

1. Measure from the adaptor disc face to the gear face and record the measurement.
2. Loosen set screws holding gear to pot shaft and remove gear.
3. Remove pot nut and washer.
4. Replace pot and tighten pot nut.
NOTE: On single turn pots — cut shaft to length of original pot shaft.
5. Put gear on shaft to original location measured in step 1.
6. Insert feedback assembly into unit and secure with 3 (Item 23) screws.
7. Remove wires from old potentiometer one at a time and transfer to new potentiometer. Use 25 watt solder iron.
8. Align.

B. POTENTIOMETER — MULTI-TURN ASSEMBLY

1. Hold feedback assembly and rotate gear CW until lower limit switch is tripped.
2. Loosen set screw (7) holding pot shaft to multi-turn screw.
3. Loosen pot nut and pull out pot.
4. Turn shaft of new potentiometer to its CW end then turn the shaft back 1/2 turn.
5. Insert the pot into the mounting frame using the pot nut and lockwasher to secure the body and the set screw to lock the shaft to the multi-turn screw.

6. Turn the feedback gear CCW until the upper switch trips to check that the end stop in the pot does not hit prior to the switch tripping. If the end stop hits first, reset the switch trip screw.
7. Rotate the gear to the approximate center of travel.
8. Insert the assembly into the unit and secure with 3 (Item 23) screws.
9. Remove wires from old potentiometer one at a time and transfer to new potentiometer. Use 25 watt solder iron.
10. Align.

C. POTENTIOMETER — CAM SWITCH ASSEMBLY

1. Measure from the feedback frame mounting face to the gear face and record the measurement.
2. Loosen the set screws holding the gear to the shaft and remove the gear.
3. Loosen the set screw in each cam.
4. Loosen the pot nut and pull the pot out of the frame while observing which way the cams were installed.
5. Insert new pot while putting lockwasher, pot nut and cams onto pot shaft. Tighten nut.
NOTE: Installing cams upside down will cause access problems to set screws in final alignment.
6. Position gear on shaft to original dimension measured in step 1 and tighten set screws.
7. Mount feedback assembly in unit and secure with 3 (Item 23) screws.
8. Remove wires from old potentiometer one at a time and transfer to new pot. Use 25 watt solder iron.
9. Align.

GEARING REPLACEMENT

1. Disconnect power.
2. Remove unit from device it is mounted to.
3. Remove 2 (Item 9) screws which hold plate (Item 8) to base (Item 1).
4. Lift out plate with feedback assembly and terminal bracket.
5. Check input shaft and bearings — replace if worn.
6. Replace worn gears as needed.

INPUT SHAFT REMOVAL

- a. Remove retaining ring (Item 7).
 - b. Remove input shaft gear (C) if it is larger in diameter than the input shaft clearance hole. (Gear is held with 2 set screws thru hub.)
 - c. Pull input shaft out of housing, along with bearing (Item 5) and seal (Item 15) — if seal is in unit.
 - d. Replace worn parts.
 - e. Re-assemble in reverse order, lubricating gears.
7. Align.