

# rotork<sup>®</sup>

Keeping the World Flowing  
for Future Generations

## CP Range Pneumatic Actuator

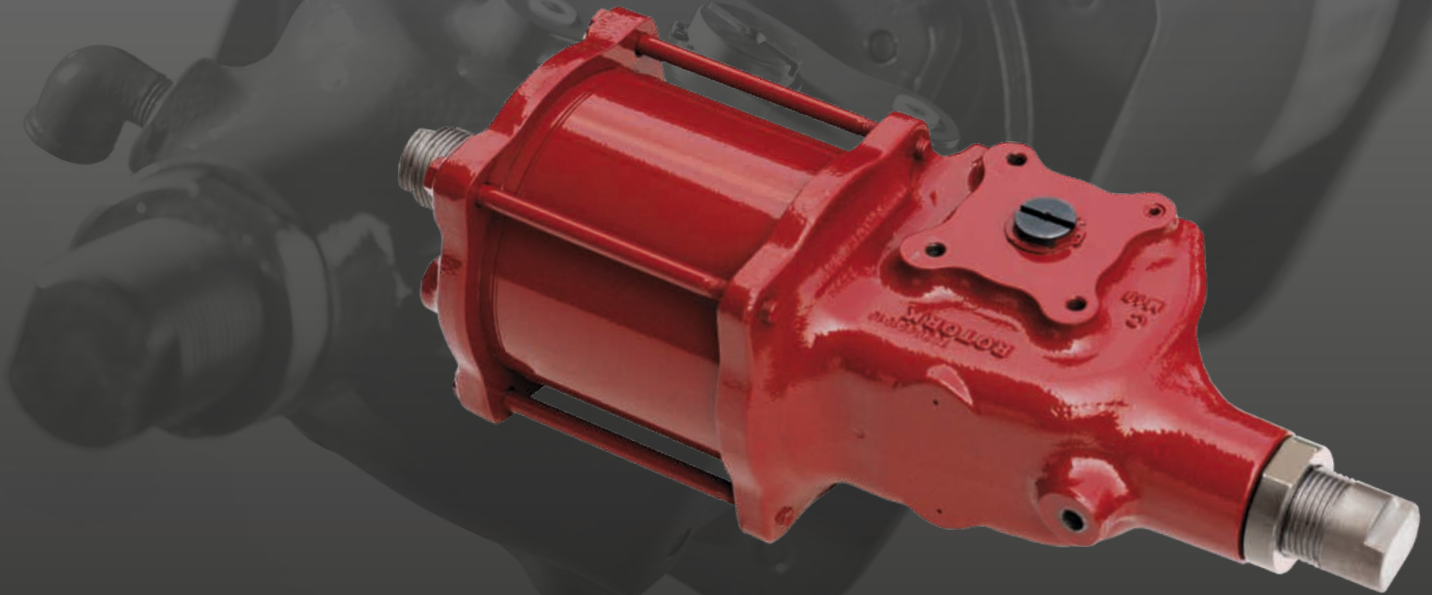

Installation, Commissioning and Maintenance Manual

## Contents

Section	Page	Section	Page
1. Introduction	3	10. Installation on Valve	9
2. Standards and Regulations	3	10.1 Preliminary Actions	9
3. General Information	4	10.2 Instructions	9
4. Health and Safety	4	11. Removal from Valve	10
4.1 Residual Risks	4	12. Operation	11
4.2 Thermal Risks	4	12.1 Description	11
4.3 Noise	4	12.2 Operating Description	12
4.4 Health Risks	4	12.3 Manual Override	12
4.5 Mechanical Risks	4	12.4 Angular Stroke Setting	14
4.6 Magnetic Risks	5	12.5 Pneumatic Power Supply	21
5. Labels and Nameplates	5	12.6 Pneumatic Connections	21
6. Operating Limits	6	12.7 Electrical Connections	22
6.1 Allowed Fluid Types	6	12.8 Start Up	22
6.2 Expected Lifetime	6	13. Dismantling and Disposal	23
6.3 Tightening Torque Chart	6	14. Rotork Sales and Service	23
7. Handling and Lifting	7	15. Troubleshooting	24
7.1 Lifting Recommendations	7	16. Periodic Maintenance	25
7.2 Lifting Instructions	7	17. Part List	42
8. Storage	8	18. Grease and Hydraulic Oil Specification	47
9. Long Term Storage	8	18.1 Grease	47



*Single effect size 055/065*



*Single effect size 035/045*



*Double effect*

This manual contains important safety information. Please ensure it is thoroughly read and understood before installing, operating or maintaining the equipment.

Rotork reserves the right to modify, amend and improve this manual without notice.

Due to wide variation in the terminal numbering of actuator products, actual wiring of this device should follow the print supplied with the unit.

## 1. Introduction

---

This manual covers maintenance aspects and instructions specific for the CP range actuators. General information on Rotork actuators are described in the User Manual, delivered separately.

In this manual, warning indications are represented by icons, according to ISO 7010 Safety Signs:



Generic danger



Hand crush/pinch point



Electrocution



Explosive material

### Customer Service

For technical assistance, please contact  
Rotork customer service

E-mail: [rfs.international@rotork.com](mailto:rfs.international@rotork.com)

Rotork, Via Padre Jacques Hamel, 138B, Porcari,  
Lucca, 55016, IT. Tel: +39 0583-222-1

Rotork plc, Brassmill Lane, Bath, UK. Tel +44 (0)1225 733200

## 2. Standards and Regulations

---

Actuators destined for European member states have been designed, built and tested according to the Quality Control System, in compliance with the EN ISO 9001:2008 standard and with the following regulations/directive.

- 2006/42/EC: Machinery Directive.
- 2014/68/EU: Pressure Equipment Directive (PED).
- 2014/34/EU: Directive for safety equipment and systems to be used in potentially explosive atmospheres (ATEX).
- 2014/30/EU: Electromagnetic Compatibility Directive.
- EN ISO 12100: Machinery Safety Directive.
- EN 60079-14: Explosive atmospheres - Part 14: Electrical installations design, selection and erection.
- ISO 80079-36: Non-electrical equipment for explosive atmospheres - Basic method and requirements.
- EN 1127-1: Explosive atmospheres – Explosion prevention and protection.
- ISO 80079-37: Non-electrical equipment for explosive atmospheres - Non-electrical type of protection construction safety "c", control of ignition sources "b", liquid immersion "k".
- UNI EN ISO 7010: Safety Signals.

### 3. General Information

This manual is produced to enable a competent user to install, operate and maintain the Rotork CP Actuator Single and Double Effect (CP/S and CP/D).

The mechanical installation should be carried out as outlined in this manual and also in accordance with any relevant national standard codes of practice.

Maintenance and operation should be carried out in accordance with the National Legislation and Statutory Provisions relating to the safe use of this equipment, applicable to the site of installation.

Any inspection or repair in a Hazardous Area should not be undertaken unless it conforms to National Legislation and Statutory Provisions relating to the specific Hazardous Area.

Only Rotork approved replacement parts should be used. Under no circumstances should any modification or alteration be carried out on the equipment, as this could invalidate the conditions under which its certification was granted.

Only trained and experienced operators should be allowed to install, maintain and repair Rotork Actuators. Work undertaken must be carried out in accordance with instructions in this manual. The user and those persons working on this equipment should be familiar with their responsibilities under any statutory provisions relating to the Health and Safety of their workplace.

Operators should always wear appropriate Personal Protection Devices (PPDs) in line with the existing plant regulations.

#### Appropriate Usage

Rotork CP series actuators have been specifically developed to motorize quarter-turn valves, such as ball valves, butterfly valves or plug valves installed on pipelines for oil & gas transport and distribution.

**⚠ Improper use can damage the equipment or cause dangerous situations for health and safety. Rotork declines any responsibility for damage to people and/or objects resulting from the use of the equipment for applications different from those described in the present manual.**

### 4. Health and Safety

Before installing the equipment, verify it is suitable for the intended application. If unsure consult Rotork.

#### 4.1 Residual Risks

Residual risks resulting from equipment risk evaluation performed by Rotork.

#### 4.2 Thermal Risks

Risk	Hot/Cold surface during normal operation (RES_01).
Preventive measures	Operators should wear protective gloves.

#### 4.3 Noise

Risk	Noise >85 dB during operation (RES_05).
Preventive measures	Operators should wear ear protections. Operators should not stand near the equipment during operation.

#### 4.4 Health Risks

Risk	Pressurized fluid ejection during normal operation (RES_02).
Preventive measures	All fittings must be properly sealed. All fixing clamps must be correctly tightened and sealed.
Risk	Risk of intoxication (according to the type of medium utilized) (RES_06).
Preventive measures	Operators must use P.P.Ds and any other equipment (breathing apparatus) based on the type of supply medium.

#### 4.5 Mechanical Risks

Risk	Uncontrolled movement (remote operation) (RES_03). (This risk is applicable only for actuator provided with Remote Control Panel).
Preventive measures	Assure that the actuator can not be operated remotely. Prior to starting, remove pneumatic supply, vent all pressure vessels, and remove electrical power.
Risk	Presence of moving parts (center body, valve adapter) (RES_04)
Preventive measures	Do not perform start-up or test the actuator if the cylinder tube is removed.
Risk	Loss of stability with possible parts projection (RES_08).
Preventive measures	Do not disassemble the actuator in case of malfunctioning. Follow instructions in the present manual and contact Rotork.

## 4. Health and Safety

Preventive measures	Foresee periodic maintenance procedure to verify tightening.
Risk	Presence of potential energy (RES_10) during dismantling.
Preventive measures	Do not disassemble the actuator during dismantling. Follow instructions in the present manual and contact Rotork.

### 4.6 Magnetic Risks

Risk	Risk of magnetic field/disturbance and exothermic reactions (RES_011).
Preventive measure	<p>The End User shall assure that actuator and its components are installed far from magnetic field, electro-magnetic field, radioactive source, electroacoustic transducer which could modify its behavior.</p> <p>The End User is in charge to avoid that exothermic reactions can verify.</p> <p>Avoid maintenance operations with acid/basic solutions.</p>

## 5. Labels and Nameplates

The following label is applied externally to the Actuator:



Fig 5.1 Actuator label

The TX surface temperature class is not provided since the actuator has not internal heat source. Maximum actuator temperature is near the environmental or exercise fluid temperature, whichever is the greater. Normal operating temperature is about -30 to +100 °C (-22 to +212 °F). Temperature range is specified within the project specific technical documentation. Special applications out of previous range are available upon request.

ATEX plate does not indicate the maximum environmental and/or exercise fluid temperature; this information is reported within the project specific technical documentation.

For CE (PED) marked actuator the following label is also used:

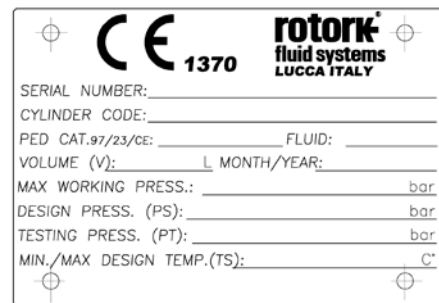

Fig 5.2 Actuator PED label

It is not allowed to remove the label.

## 6. Operating Limits

Temperature: -30 to +100 °C (-22 to +212 °F)  
for standard applications  
-20 to +100 °C (-4 to +212 °F)  
for PED applications  
-40 to +100 °C (-40 to +212 °F)  
for low temperature application  
-60 to +100 °C (-76 to +212 °F)  
for ultra-low temperature application

Design pressure: up to 12 barg. See PUB013-002 for details

Operating pressure: See PUB013-002

**⚠ Do not use the equipment outside its operating limits. Verify operating limits on the nameplate.**

Prevent external surface temperature to reach the ignition point in potentially explosive environments.

The actuator surface temperature is strictly dependent on the temperature of the process fluid used and by the irradiation's conditions. The end-user has to check the surface temperature of the assembly, so that this cannot go over the minimum gas ignition's temperature, which classifies the area with the explosion's risk.

Dust and debris accumulated on the actuator will slow down its cooling and contribute to the increase of its external temperature.

### 6.1 Allowed Fluid Types

The pneumatic actuator is designed to be operated with Gas, Instrument air with particles filtering  $\leq 40 \mu\text{m}$  (Class 7 according ISO 8573-1, table 1), pressure dew point  $\leq -20 \text{ °C}$  ( $-4 \text{ °F}$ ) (Class 3 according ISO 8573-1, table 2), total concentration of oil  $\leq 5 \text{ mg/m}^3$  (Class 4, according ISO 8573-1, table 3); if not differently specified in specific project documentation.

### 6.2 Expected Lifetime

Expected Lifetime greater than 25 years, in normal service conditions and with planned maintenance.

### 6.3 Tightening Torque Chart

RECOMMENDED TIGHTENING TORQUE (Class 8.8 bolts)		
Bolt Size	Nm	Ft. Lbs
M6	8.5	6
M8	20	15
M10	40	30
M12	55	40
M14	110	81
M16	220	162
M20	430	317
RECOMMENDED TIGHTENING TORQUE EXCEPTIONS		
ACTUATOR TIE RODS (AND CYLINDER FLANGEG TO HOUSING CP055 / 065 ONLY)		
M16 (CP055)	130	96
M16 (CP065)	180	133

## 7. Handling and Lifting

**⚠ Only trained and experienced personnel should handle/lift the actuator.**

The actuator is supplied packed on pallets suitable for normal handling.

**⚠ Handle the actuator with care. Never stack pallets.**

### 7.1 Lifting Recommendations

- The lifting device and the sling must be suitably rated for the actuator weight and dimensions
- Do not use damaged sling(s)
- The sling must not be shortened with knots or bolts or any other makeshift device
- For lifting purposes, use only suitable lifting tools
- Do not drill holes, weld eye bolts or add any other type of lifting device on the actuator external surface
- Do not lift the actuator and valve combination with the actuator lifting lugs
- Every assembly must be estimated separately for a safe and correct lifting
- Avoid pulls or abrupt movements during lifting. Avoid pushing the load
- During lifting operations, do not handle the slings and/or the actuator

**⚠ Do not step underneath suspended load.**

### 7.2 Lifting Instructions

**NOTE: Indication of weight, center of gravity, lifting points are reported within specific project documentation.**

**For actuator orientation different from the horizontal one please consult project specific documentation before lifting.**

- Prior to lifting the actuator, remove electrical power and vent all pressure vessels (if present).
- Place the textile eye slings as shown in Fig 7.1.

**⚠ The actuator must remain horizontal; balance the load.**

- Angle  $\beta$  must be between  $0^\circ$  and  $45^\circ$  as shown in Fig 7.2.



Fig 7.1 Lifting

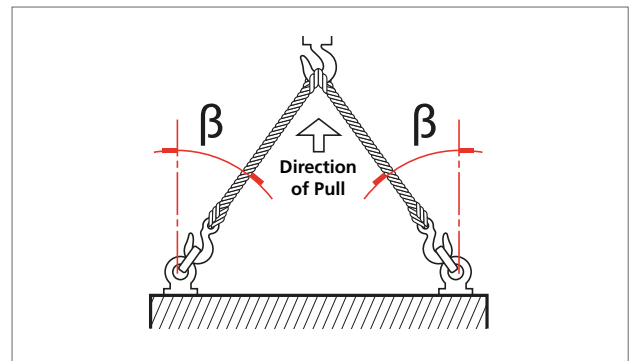

Fig 7.2 Lifting angle

## 8. Storage

---

Rotork actuators have been fully tested before leaving the factory.

In order to keep the actuator in good condition until installation, at least the following measures are recommended:

- Check presence and assembling of dust plugs
- Keep the actuator on shipping pallet until installation

**⚠ Never put the actuator directly on the ground.**

- Protect the valve coupling area (adapter flange and coupling joint, etc.) with rust preventive oil e.g. Mobilarma LT or equivalent
- Protect against weather action, covering the actuators with appropriate polyethylene sheets
- Check the actuator condition every 6 months and verify the above protection measures remain in place

**⚠ Remove package only at the installation time.**

**⚠ Actuator vent ports must be protected with polyethylene sheet to prevent water ingress during storage.**

## 9. Long Term Storage

---

If long term storage is necessary, further operations must be carried out to maintain the actuator in a good working condition:

- Replace the plastic plugs with metal plugs
- Stroke the actuator every 12-months:
  - Cycle the actuator (using filtered, dehydrated air) to the working pressure indicated on the name plate
  - Cycle the actuator with all the existing controls (i.e. two complete strokes - one open, one closed) at least 5 times
  - Cycle the actuator fitted with the hydraulic manual override by means of the hand pumps for 4 complete strokes
  - Disconnect the pipeline gas and electric (if present) supply from the actuator, and carefully close all the threaded connections of the actuator
- Remove electrical components covers (if present) to ensure control terminals are clean and free from oxidation and humidity. Reassemble the covers
- In case of storage for over 12 months prior to installation, it is recommended to operate the actuator to verify correct operation



## 10. Installation on Valve

Before proceeding, read and understand the Health and Safety information.

**Note: The valve should be properly secured prior to perform following operations according to instructions provided by the Valve's Manufacturer.**

 **Prior to performing any operations check the operating drawings and TAG numbers.**

Consult Rotork for any additional information.

### 10.1 Preliminary Actions

 **Verify the ATEX classification of the actuator is compatible with the plant zoning. Refer to actuator nameplate.**

- The centreline of the cylinder is usually aligned to the centreline of the associated pipe work
- Ensure all fasteners are adequately tightened, to avoid loosening during operation, taking into account the vibrations induced by the dynamics of the pipeline
- Piping used to provide pipeline gas power to the actuator must be free from contaminants and debris. Ensure tubing runs are adequately fastened and supported to minimize repetitive stress induced the dynamics of the pipeline. Ensure there are no leaks from any pipeline gas connections. Tighten as required

### 10.2 Instructions

The assembling can be performed by:

- Mounting directly using the actuator housing flange with threaded holes
- Using an adapter and a coupling joint between the actuator and the valve

The assembly position of the actuator must be in accordance with the actuator design, plant requirements and the valve model.

In order to assemble the actuator onto the valve, proceed as follows:

- Verify the coupling dimensions of the valve flange and stem; they must meet the actuator coupling dimensions
- Set the valve in the closed position. The actuator is supplied in the closed position. Check the position of the actuator by means of the position indicator on the center body or on the limit switch (if present)
- Clean the coupling flange of the valve and remove anything that might prevent adherence to the actuator flange. Grease shall be completely removed
- Lubricate the valve stem with oil or grease, to facilitate assembling
- Lift the actuator according to Handling and Lifting instructions (section 7)

- If possible, place the valve stem in a vertical position to facilitate assembling - in this case the actuator must be lifted while the coupling flange is kept in the horizontal position
- If the assembly is done using an adapter and a coupling joint, assemble the coupling joint onto the valve stem before proceeding with the assembly of the actuator
- Do not exert any force while lowering the actuator onto the valve

Installation must be performed by qualified personnel.

 **Hands must be kept away from the coupling area.**

- Fix the actuator to the valve by means of threaded connections (bolts, stud bolts and nuts)
- Tighten the bolts or the nuts of the connecting stud bolts to the correct torque, in accordance with the size and material characteristics of the bolts installed by the customer

 **Support the actuator until fully installed and fixing bolts are correctly tightened.**

 **Attention: Do not pressurize the actuator/valve adapter.**

- Check for possible damage to the paint-work and repair if necessary, according to painting specification

## 11. Removal from Valve

The End user is in charge of removing the actuator from the valve.

**⚠ Removal shall be performed only by qualified staff, wearing/using appropriate personal protection devices.**

**⚠ Do not remove the actuator if the valve is blocked in the intermediate position. Contact Rotork.**

In order to disassemble the actuator from the valve, proceed as follows:

- Cut off electrical power supply
- Cut off pneumatic supply
- Remove the supply pipes from the actuator
- Release any pressure from the control group
- Remove control and signal lines from electric components (if any)
- Sling the actuator in line with Handling and Lifting instructions (section 7)
- Unscrew the bolts or the nuts from the stud bolts fixing the actuator to the valve
- Lift and remove the actuator from the valve



Fig 11.1 Actuator/valve assembling example

## 12. Operation

The following instructions must be followed and integrated into End User safety program when installing and using Rotork products. Read and save all instructions prior to installing, operating and servicing this product.

Follow all warnings, cautions and instructions marked on and supplied with the product.

**Install equipment as specified in Rotork installation instructions and as per applicable local and national codes of practice. Connect all products to the proper pipeline gas sources.**

When replacement parts are required, ensure that the qualified service technician uses only replacement parts specified by Rotork.

Substitutions will invalidate any hazardous area certification and may result in fire, electrical shock, other hazards or improper operation.

**⚠ Do not operate the actuator without the protection guards installed.**

### 12.1 Description

The CP/S series actuators are pneumatic single acting – spring return actuators. The compact and efficient design yields surprisingly high torques even at low pressures. The design concepts found in Rotork’s large, heavy-duty actuators has been applied to the CP range, which brings heavy-duty actuator qualities to small, quarter-turn actuators.

The CP/S series can be assembled in the fail to close or fail to open version and can be fitted with an emergency manual override suitable to operate the actuator in the event of fluid supply failure.

This device can be of mechanical screw type operated using a wrench or a handwheel.

The main components of CP/S actuators are shown in Fig 12.1, Fig 12.2 and Fig 12.3.

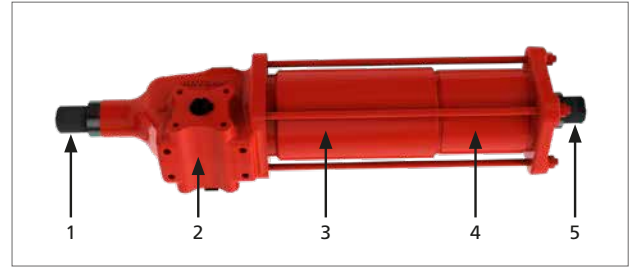

Fig 12.1 CPIS (055-065) main components

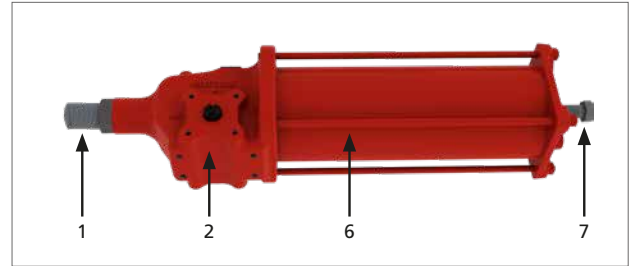

Fig 12.2 CPIS (035-045) main components

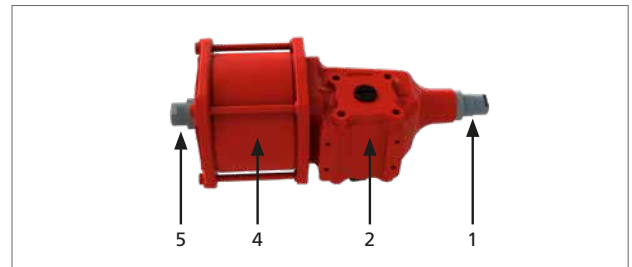

Fig 12.3 CPID main components

Table 1: CPIS Parts list

IT	DESCRIPTION	QTY
1	Mechanical stop bolt	1
2	Center body	1
3	Spring cartridge (055-065)	1
4	Cylinder tube (055-065)	1
5	Mechanical Stop bolt (055-065)	1
6	Cylinder tube (035-045)	1
7	Stop screw (035-045)	1

Table 2: CPID Parts list

IT	DESCRIPTION	QTY
1	Mechanical stop bolt	1
2	Center body	1
4	Cylinder tube	1
5	Mechanical stop bolt	1

## 12. Operation

Main components of a CP actuator are:

- A scotch-yoke mechanism made of ductile iron which transforms the linear movement of the pneumatic cylinder and of the spring (for single acting actuator) into a rotary movement suitable for operating quarter turn valves, such as ball valves, butterfly valves or plug valves

The scotch-yoke mechanism in symmetric execution is inside a weatherproof housing, made of ductile iron

The carbon steel axial bar is provided with Nitreg treatment (for CP055 and CP065) or Chromium plated (for CP035 and CP045) and supported by bushing made of bronze and Teflon to ensure minimum friction and long service

The Nitreg process provides increased surface hardness, reduced surface roughness as well as extremely high resistance to corrosion

- A Pneumatic cylinder, made of carbon steel

The cylinder tube is Nickel-plated internally

The piston is made of carbon steel with a dynamic floating seal

The dynamic seals of the cylinder are specifically designed to enable the use of the actuator without lubrication

- The spring, within the cartridge (only for 055-065 size) is contained by the piston and piston rod thus eliminating the possibility of inadvertent release of spring force

The design also allows access to the piston seal without the disassembly of the spring cartridge

- Two mechanical stop bolts are located in the end flange of the pneumatic cylinder and in the housing to ensure accurate angular stroke adjustment
- A mechanical visual position indicator directly connected to the valve stem that shows the position of the valve all along the actuator stroke

Upon request, CP/S series actuators can be equipped with additional accessories (limit switches box, positioner, position transmitter, etc.)

Use only control devices supplied by Rotork.

### 12.2 Operating Description

Please refer to the Operating Diagram supplied for the specific actuator.

In case of use of CP/D actuators in SIL applications the System Integrator must fulfill all requirements reported in par. 11.2.11 of standard IEC61511-1.

**⚠ Do not use the actuator outside 90° ±5° operating range.**

### 12.3 Manual Override

The CP series can be fitted with an emergency manual override suitable to operate the actuator in the event of fluid supply failure.

**⚠ A maximum operating time of the manual override of 24 hours, for maintenance or testing, is recommended.**

**NOTE: The use of manual override is not recommended in SIL applications. If it is necessary, strictly follow instructions reported in the following paragraphs.**

The manual override is mechanical type.

For CP series actuator the manual override consists of a jackscrew device controlled by a wrench (M type) or handwheel (MH type).

**⚠ Before operating the mechanical manual override, ensure that the cylinder is not pressurized and that the actuator is in the fail position, then proceed as indicated in the following paragraphs.**

**⚠ Before re-starting the actuator with air supply, rotate the jackscrew again so as to set the actuator in its original position.**

After each use, verify that the manual override has been disengaged before returning to remote operation.

## 12. Operation

### 12.3.1 Fail to Close, Single-Acting Actuator

- Rotate the jackscrew with a wrench or with a handwheel, counter-clockwise, to open the valve



Fig 12.4 "Fail to close" actuator with manual override „M" type

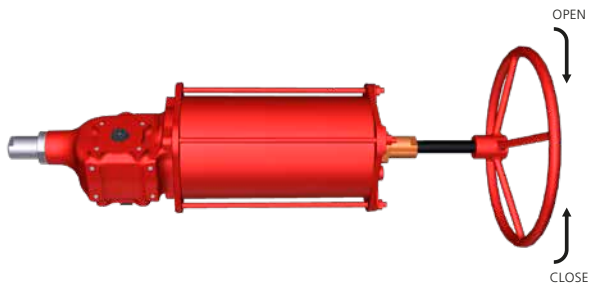

Fig 12.5 "Fail to close" actuator with manual override „MH" type

### 12.3.2 Fail to Open, Single-Acting Actuator

- Rotate the jackscrew with a wrench or with a handwheel, clockwise, to close the valve



Fig 12.6 "Fail to open" actuator with manual override „M" type

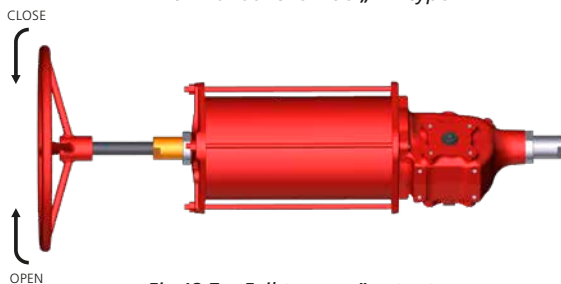

Fig 12.7 "Fail to open" actuator with manual override „MH" type

### 12.3.3 Opening Operation for Double-Acting Actuator

- Rotate the jackscrew with a wrench or with a handwheel, counter-clockwise, to open the valve

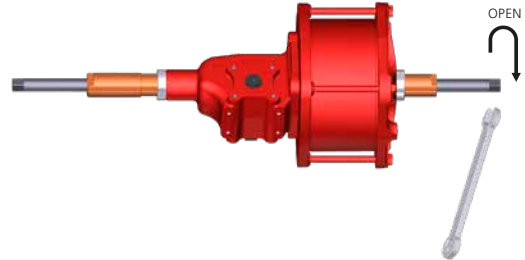

Fig 12.8 Opening operation for CPID with manual override „M" type

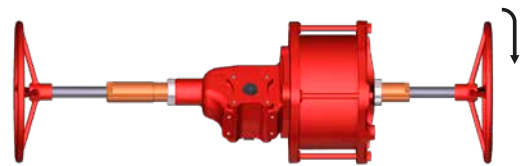

Fig 12.9 Opening operation for CPID with manual override „MH" type

### 12.3.4 Closing Operation for Double-Acting Actuator

- Rotate the jackscrew with a wrench or with a handwheel, clockwise to close the valve

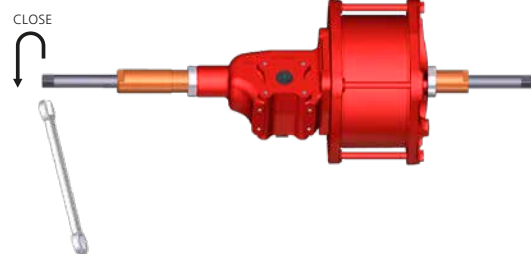

Fig 12.10 Closing operation for CPID with manual override „M" type

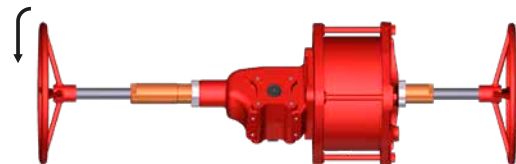

Fig 12.11 Closing operation for CPID with manual override „MH" type

Clean the jackscrew regularly and grease it afterwards. Use Shell Gadus S5 V25Q grease.

## 12. Operation

### 12.4 Angular Stroke Setting

**⚠️ Certain valves incorporate their own stops. For such valves, it is recommended that the actuator stop bolt positions coincide with the valve stop position.**

Contact the valve manufacturer to set the valve mechanical stops.

**⚠️ An incorrect setting of angular stroke could cause damages to actuator, valve and/or to personnel.**

#### 12.4.1 Single-Acting Actuator, Cylinder Stop Bolt Setting (size 055-065)

Perform the following operations as first setting.

Adjust the stop bolt located in the end flange of the cylinder as follows:

- A. Verify the absence of pressure
- B. Loosen stop nut (7) and O-ring (6)
- C. Screw the stop bolt until stop
- D. Slowly pressurize the cylinder to detach the stop bolt from the piston



- E. To increase angular stroke, rotate the stop bolt (8) anti-clockwise
- F. Remove pressure
- G. Verify the newly obtained angular position with one stroke
- H. Repeat operations A to F, until the desired angle is obtained

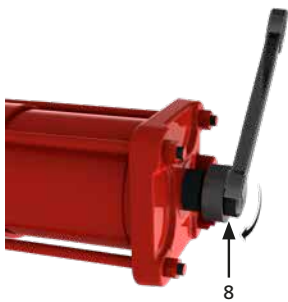

- I. To decrease angular stroke, rotate the stop bolt (8) clockwise
- J. Remove pressure
- K. Verify the newly obtained angular position with one stroke
- L. Repeat operations A to D and I to J, until the desired angle is obtained

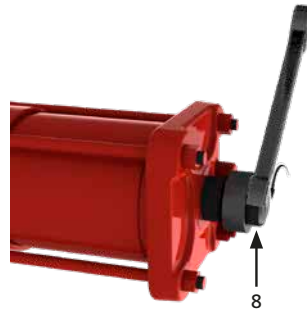

- M. Re-position O-ring (6) between flange and stop nut (7)

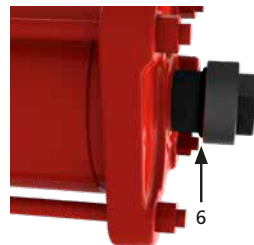

- N. Hold stop bolt (8) with a wrench and carefully tighten nut (7)



## 12. Operation

### 12.4.2 Single-Acting Actuator, Cylinder Stop Bolt Setting (size 035-045)

Perform the following operations as first setting.

Adjust the stop bolt located in the end flange of the cylinder as follows:

- A. Verify the absence of pressure
- B. Loosen stop nut (7) and O-ring (6)
- C. Screw the stop bolt until stop
- D. Slowly pressurize the cylinder to detach the stop bolt from the piston

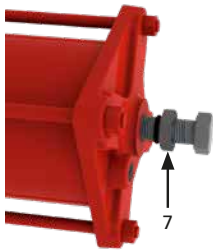

- E. To increase angular stroke, rotate the stop screw (8) anti-clockwise
- F. Remove pressure
- G. Verify the newly obtained angular position with one stroke
- H. Repeat operations A to F, until the desired angle is obtained

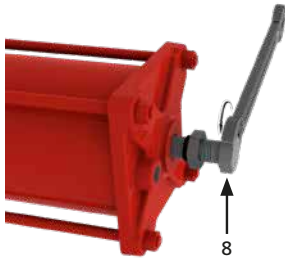

- I. To decrease angular stroke, rotate the stop screw (8) clockwise
- J. Remove pressure
- K. Verify the newly obtained angular position with one stroke
- L. Repeat operations A to D and I to J, until the desired angle is obtained



- M. Re-position O-ring (6) between flange and stop nut (7)

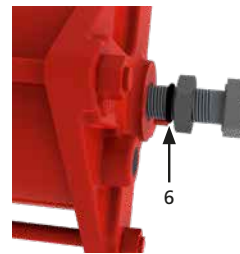

- N. Hold stop screw (8) with a wrench and carefully tighten nut (7)



## 12. Operation

### 12.4.3 Single-Acting Actuator, Center Body Stop Bolt Setting (size 035-045-055-065)

Perform this setting after having set the stop bolt on cylinder.

Adjust stop bolt (1) screwed into the housing, as follows:

- O. Pressurize the cylinder until reaching the fully open position, and verify the actuator stroke stop
- P. Depressurize the cylinder to adjust the angular stroke setting
- Q. Loosen stop nut (2) and O-ring (3)

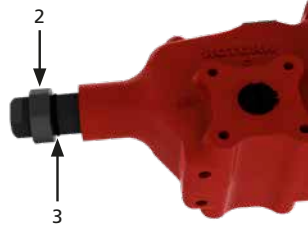

- R. To increase angular stroke, rotate the stop bolt (1) anti-clockwise

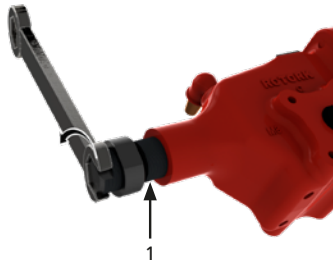

- S. To decrease angular stroke, rotate the stop bolt (1) clockwise

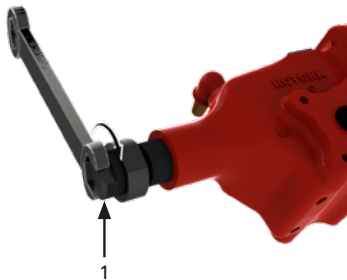

- T. Verify the newly obtained angular position with one closing stroke

- U. Repeat this operation until the desired angle is obtained

- V. Re-position O-ring (3) between flange and stop nut (2)

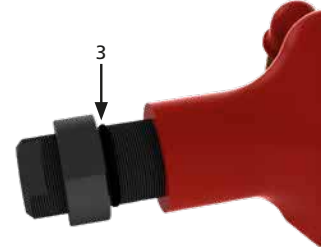

- W. Hold stop bolt (1) with a wrench and carefully tighten nut (2)

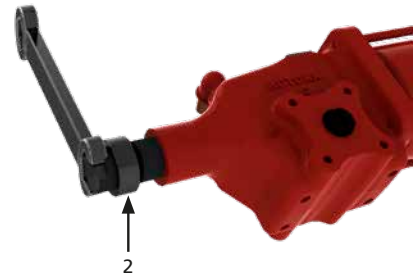



## 12. Operation

### 12.4.4 Single-Acting Actuator with MH Type Manual Override, Cylinder Stop Bolt Setting

Perform the following operations as first setting.

Adjust the stop bolt located in the end flange of the cylinder as follows:

- A. Verify the absence of pressure
- B. Verify the handwheel is fully retracted
- C. Loosen stop nut (7) and O-ring (6)
- D. Screw the stop bolt until stop
- E. Slowly pressurize the cylinder to detach the stop bolt from the piston

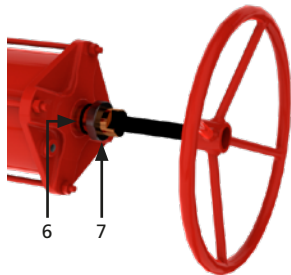

- F. To increase angular stroke, rotate the stop bolt (8) anti-clockwise
- G. Remove pressure
- H. Verify the newly obtained angular position with one stroke
- I. Repeat operations A to G, until the desired angle is obtained

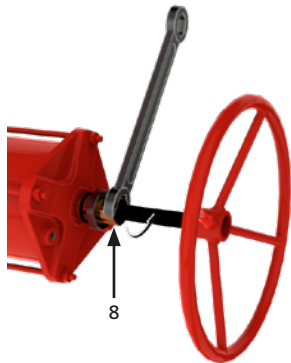

- J. To decrease angular stroke, rotate the stop bolt (8) clockwise
- K. Remove pressure
- L. Verify the newly obtained angular position with one stroke
- M. Repeat operations A to E and J to K, until the desired angle is obtained

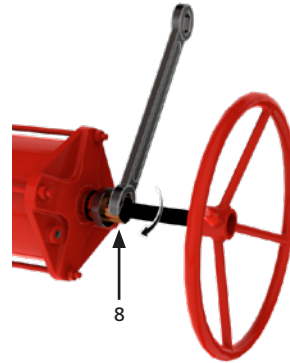

- N. Re-position O-ring (6) between flange and stop nut (7)

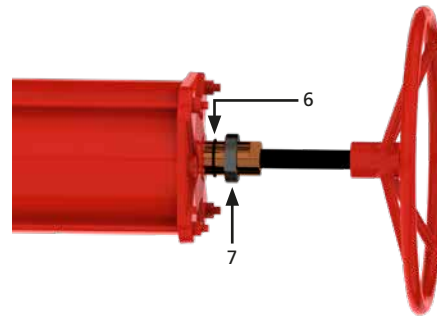

- O. Hold stop bolt (8) with a wrench and carefully tighten nut (7)

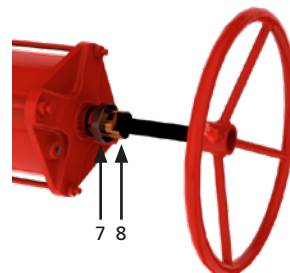

## 12. Operation

### 12.4.5 Cylinder Stop Bolt Setting (Double-Acting Actuator)

Adjust stop bolt (1) screwed into the end flange, as follows:

1. Pressurize the cylinder from the end flange side until the actuator reaches the fully open position, and verify the actuator stroke stop
2. Pressurize the cylinder from the second port side to detach the stop bolt from the housing
3. Loosen stop nut (2)

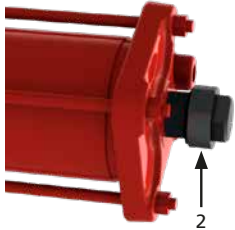

4. To increase angular stroke, rotate the stop bolt (1) anti-clockwise

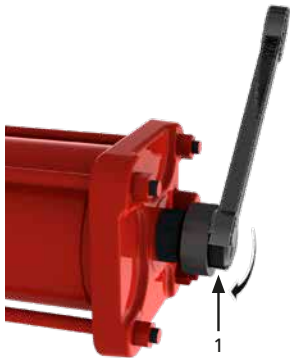

5. To decrease angular stroke, rotate the stop bolt (1) clockwise

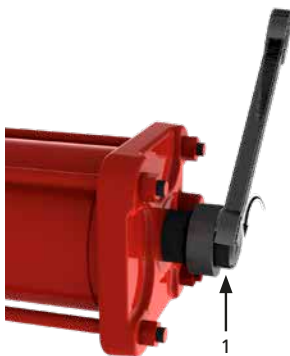

6. Verify the newly obtained angular position with one closing stroke
7. Repeat this operation until the desired angle is obtained
8. Ensure O-ring (3) is correctly positioned

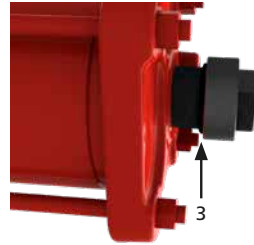

9. Hold stop bolt (1) with a wrench and tighten nut (2)



## 12. Operation

### 12.4.6 Center Body Stop Bolt Setting (Double-Acting Actuator)

Adjust stop bolt (8) screwed into the housing, as follows:

1. Pressurize the cylinder from the second port until reaching the fully stroke end position, and verify the actuator stroke stop
2. Pressurize the cylinder from the end flange side to detach the stop bolt from the piston
3. Loosen stop nut (7) and O-ring (6)

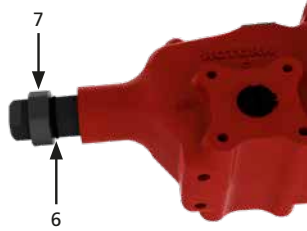

4. To increase angular stroke, rotate the stop bolt (8) anti-clockwise

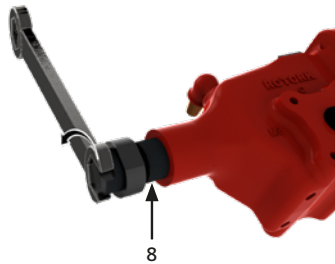

5. To decrease angular stroke, rotate the stop bolt (8) clockwise.

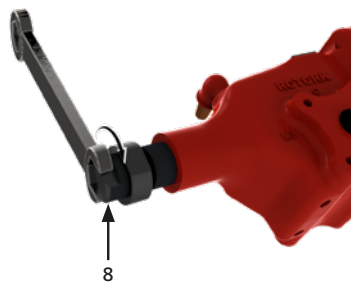

6. Verify the newly obtained angular position with one closing stroke.
7. Repeat this operation until the desired angle is obtained.
8. Re-position O-ring (6) between flange and stop nut (7)

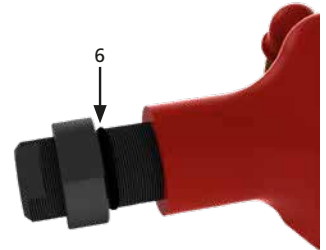

9. Hold stop bolt (8) with a wrench and tighten nut (7).

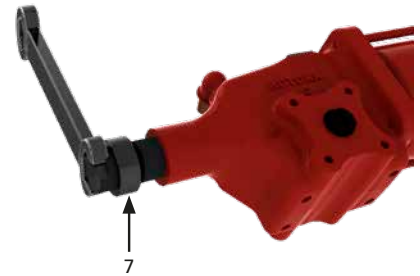

## 12. Operation

### 12.4.7 Double-Acting Actuator with MH Manual Override, Center Body Stop Bolt Setting (size 035-045-055-065).

Perform this setting after having set the stop bolt on cylinder.

Adjust stop bolt (1) screwed into the housing, as follows:

- A. Pressurize the cylinder until reaching the fully open position, and verify the actuator stroke stop
- B. Depressurize the cylinder to adjust the angular stroke setting
- C. Loosen stop nut (2) and O-ring (3)

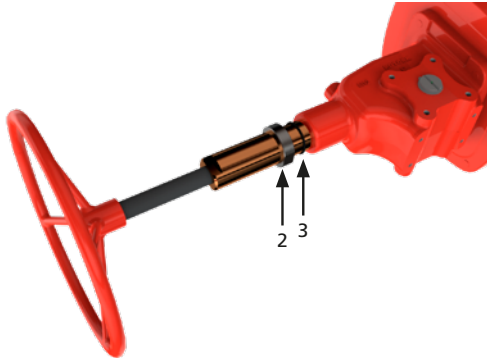

- D. To increase angular stroke, rotate the stop bolt (1) anti-clockwise

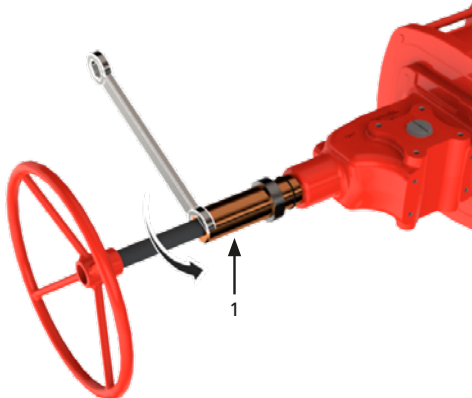

- E. To decrease angular stroke, rotate the stop bolt (1) clockwise

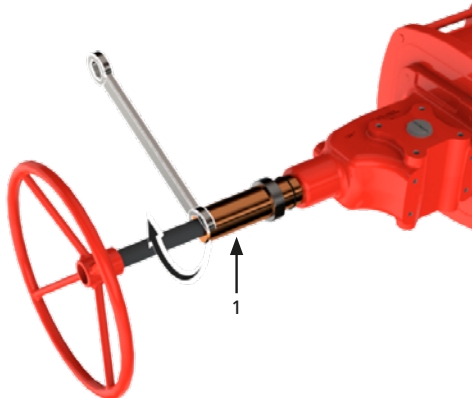

- F. Verify the newly obtained angular position with one closing stroke

- G. Repeat this operation until the desired angle is obtained

- H. Re-position O-ring (3) between flange and stop nut (2)

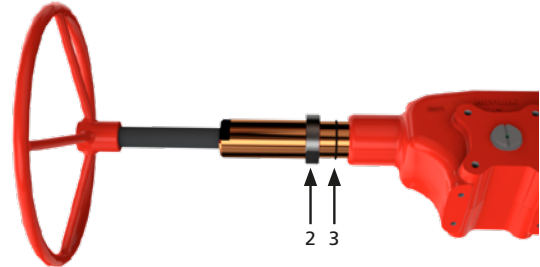

- I. Hold stop bolt (1) with a wrench and carefully tighten nut (2)

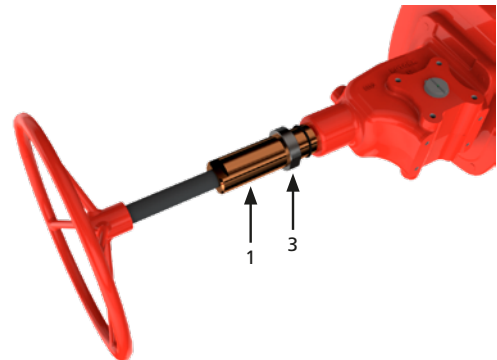

## 12. Operation

### 12.5 Pneumatic Power Supply

Verify allowed supply pressure range on actuator label.

**⚠️ Verify medium composition. Contact Rotork to check the compatibility with the supply medium.**

### 12.6 Pneumatic Connections

#### Preliminary Operations

1. Verify sizes of pipes and fittings according to applicable plant specifications
2. Clean the inside of the connection pipes by washing them with a suitable detergent and by blowing air into them
3. The connecting pipes must be properly shaped and fixed to prevent stress or loosening of threaded connections

**NOTE: For tapered-thread fluid connections, apply a thin layer of thread sealing product (Loctite 577 or equivalent) to ensure a good seal.**

**⚠️ Connect the pneumatic power source in accordance to the applicable operating diagram, please refer to specific job for details.**

**⚠️ Do not feed a single acting actuator from the spring container side after having removed the exhaust silencer, especially if the line valve is blocked.**

**⚠️ If actuator is provided of spool, avoid spool pressurization.**

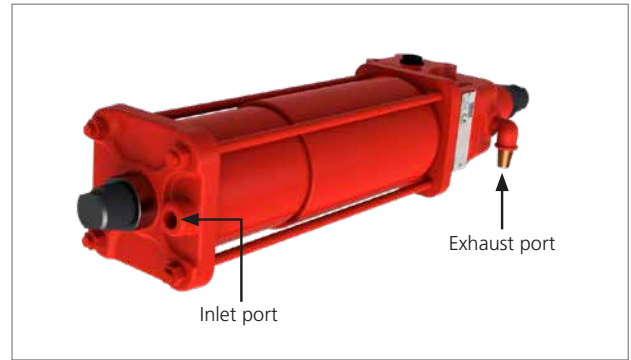

Fig 12.12 Inlet exhaust port for Single-Acting actuator

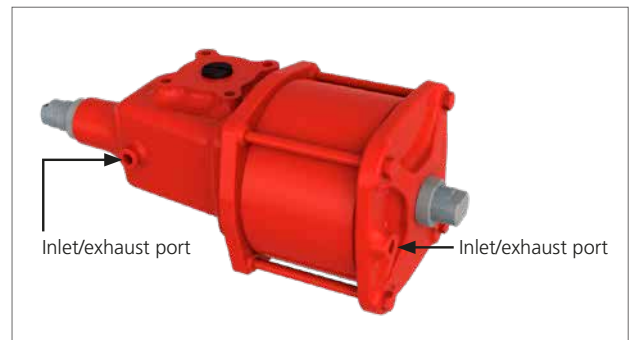

Fig 12.13 Inlet exhaust port for Double-Acting actuator (except for CPD-065)

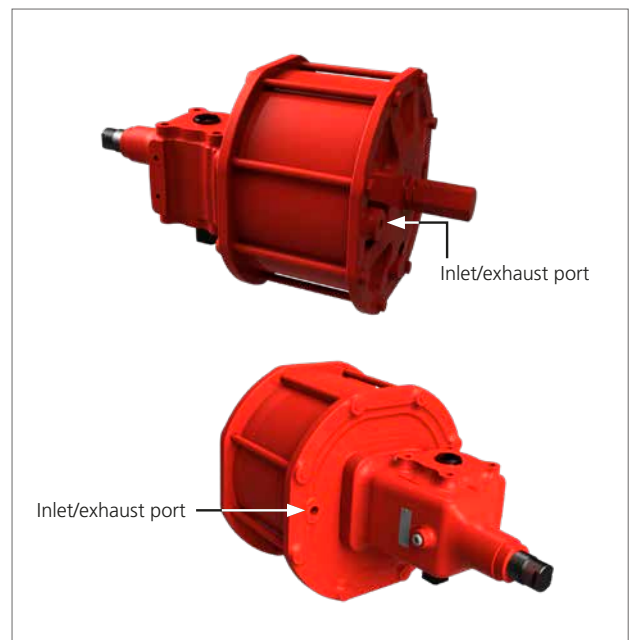





Fig 12.14 Inlet exhaust port for Double-Acting actuator CPD-065

## 12. Operation

### 12.7 Electrical Connections

 **Check electrical components supply voltage, before start-up.**

 **Access to live electrical conductors is forbidden in hazardous areas unless done under a special permit. Otherwise, all power should be isolated and the unit moved to a non-hazardous area for repair.**

 **Prevent electrostatic charges in potentially explosive areas.**

Electrical connection can be performed as follows:

- Remove power supply
- Remove the plastic protection plugs from the cable entries
- Use only appropriately certified reduction fittings, cable glands, fittings and explosion-proof cables
- The cable glands must be tightened in the threaded inlets, to guarantee the waterproof and explosion proof protection
- Pay attention to the correct installation of the O-rings of the cable glands to prevent water and debris infiltration inside electric components
- The size of the electric supply cable must suit the electric power demand
- Insert the connection cables through cable glands and perform assembly according to the cable gland manufacturer's instructions.
- Connect the cable wires to the terminal blocks in accordance with the applicable wiring diagram
- Electric connections must be made by using rigid conduits and trailing cables to prevent mechanical stresses in the cable entries
- On the unused entries of the junction box, replace the plastic plugs with approved metal plugs, in order to guarantee sealing and to comply with explosion safety protection codes
- Assemble the covers of the electric components, paying attention to seals
- Once connections have been completed, check electrical components functionality

 **Actuator and electrical components must be protected from electrical sparks, lightning, magnetic or electro-magnetic fields, at user's care.**

### 12.8 Start Up

During the start-up of the actuator, it is necessary to check if:

- Medium supply pressure is as prescribed
- The feed voltage values of electrical components (solenoid valves coils, limit switches, pressure switches etc., if applicable) are as prescribed
- Actuator controls such as remote control, local control, emergency control etc. (if applicable) work properly
- Input remote signals are correct
- The setting of control unit components is according to the plant requirements
- Pneumatic connections show no leakage. If necessary, tighten fittings
- The painted parts have not been damaged during transport, assembling or storage operations. On the contrary, after having removed rust, repair the damaged parts following the applicable painting specifications
- Actuator and all of its parties work as expected
- Operating time is in accordance with requirements

 **The End user must guarantee equal voltage potential between the valve and the actuator and provide appropriate grounding. The final user shall indicate and maintain the grounding connections on the actuator.**

### 13. Dismantling and Disposal

---

Prior to dismantling the actuator, check if any of its parts are still under pressure.

#### For Single-Acting Actuator

 **The spring cartridge module could contain potential energy due to compressed elastic elements.**

 **Grease and oil must be disposed of safely in accordance with the local environmental laws and regulations.**

- Dismount the actuator, separate and divide the various parts and components according to the type of material
- Dispose of the pieces of steel, cast iron and aluminum alloys as metal scraps
- Dispose of the rubber, PVC, resins etc. separately, in accordance with the existing national and regional regulations
- Electric components are to be separately disposed of on specialized disposal sites

Actuators manufactured after 1993 year do not contain asbestos or its by-products.

### 14. Rotork Sales and Service

---

If your Rotork actuator has been correctly installed and sealed, it will give years of trouble-free service. Should you require technical assistance or spares, Rotork guarantees the best service in the world. Contact your local Rotork representative or the factory direct at the address on the nameplate, quoting the actuator type and serial number.

Some actuators have a special spare parts list. Refer to the project specific documentation for further details.

## 15. Troubleshooting

ID	FAILURE	POSSIBLE CAUSES	CORRECTIVE MEASURES
1	Incorrect valve position	<ul style="list-style-type: none"> <li>Fault of pipeline valve</li> </ul>	<ul style="list-style-type: none"> <li>Consult the valve manufacturer's documentation</li> </ul>
2	Incorrect indication of valve position	<ul style="list-style-type: none"> <li>Incorrect signal from limit switches</li> </ul>	<ul style="list-style-type: none"> <li>Check limit switches position (see job specific documentation and limit switch box manufacturer's documentation)</li> </ul>
3	Incorrect movement	<ul style="list-style-type: none"> <li>Irregular supply of operating medium</li> </ul>	<ul style="list-style-type: none"> <li>Verify the supply pressure and adjust as necessary</li> </ul>
		<ul style="list-style-type: none"> <li>Worn parts</li> </ul>	<ul style="list-style-type: none"> <li>Contact Rotork customer service</li> </ul>
		<ul style="list-style-type: none"> <li>Fault in control panel equipment (if present)</li> </ul>	<ul style="list-style-type: none"> <li>Contact Rotork customer service</li> </ul>
		<ul style="list-style-type: none"> <li>Fault of pipeline valve</li> </ul>	<ul style="list-style-type: none"> <li>Consult the valve manufacturer's documentation</li> </ul>
4	Valve stroke not fully completed	<ul style="list-style-type: none"> <li>Insufficient gas flow</li> </ul>	<ul style="list-style-type: none"> <li>Increase gas supply flow</li> </ul>
		<ul style="list-style-type: none"> <li>Incorrect assembly between actuator and valve</li> </ul>	<ul style="list-style-type: none"> <li>Reassemble the actuator to the valve (section 10)</li> </ul>
		<ul style="list-style-type: none"> <li>Valve blocked</li> </ul>	<ul style="list-style-type: none"> <li>Consult the valve manufacturer's documentation</li> </ul>
		<ul style="list-style-type: none"> <li>Stop bolts wrong setting</li> </ul>	<ul style="list-style-type: none"> <li>Adjust stop bolt setting according to Angular Stroke Setting (section 12.4)</li> </ul>
5	Leakages	<ul style="list-style-type: none"> <li>Stop bolts wrong setting</li> </ul>	<ul style="list-style-type: none"> <li>Adjust stop bolt setting according to Angular Stroke Setting (section 12.4)</li> </ul>
		<ul style="list-style-type: none"> <li>Worn seals</li> </ul>	<ul style="list-style-type: none"> <li>Replace seals according to PM-CP2-005, PM-CP2-006, PM-CP2-007 (section 16)</li> </ul>
6	Actuator moves too fast	<ul style="list-style-type: none"> <li>No pressure on pipeline</li> </ul>	<ul style="list-style-type: none"> <li>Restore pipeline pressure</li> </ul>
		<ul style="list-style-type: none"> <li>Supply pressure greater than allowed range values</li> </ul>	<ul style="list-style-type: none"> <li>Verify the supply pressure and adjust as necessary</li> </ul>
7	Actuator moves too slow	<ul style="list-style-type: none"> <li>Fault on pipeline valve (valve hardened)</li> </ul>	<ul style="list-style-type: none"> <li>Consult the valve manufacturer's documentation</li> </ul>
		<ul style="list-style-type: none"> <li>Supply pressure lower than allowed range values</li> </ul>	<ul style="list-style-type: none"> <li>Verify the supply pressure and adjust as necessary</li> </ul>
		<ul style="list-style-type: none"> <li>Possible internal undue friction</li> </ul>	<ul style="list-style-type: none"> <li>Contact Rotork customer service</li> </ul>
8	Loss of power	<ul style="list-style-type: none"> <li>Inadequate supply pressure</li> </ul>	<ul style="list-style-type: none"> <li>Ensure that the supply pressure is above the minimum operating pressure of the actuator and that the output torque produced at supply pressure exceeds the required valve torque</li> </ul>
		<ul style="list-style-type: none"> <li>Leakage from cylinder</li> </ul>	<ul style="list-style-type: none"> <li>Replace seals according to PM-CP2-005, PM-CP2-006, PM-CP2-007 (section 16)</li> </ul>

For other problems, please contact Rotork.



## 16. Periodic Maintenance

Rotork recommends performing the following checks to help comply with the rules and regulations of the country of final installation:

**⚠ Remove pressure before proceeding with maintenance operations, discharge any accumulators or tanks (if present), except where otherwise indicated.**

### Periodic Maintenance Schedule

MAINTENANCE ACTIVITY	PERIODICITY		REFERENCE
	Months	Years	
Visual check of external components and control groups	6*	*	
Verify welding. In case of anomalies contact RFS	6*	*	
Check pneumatic connections for leaks. Tighten pipe fittings as required	-	1*	
Cleaning	-	1*	PM-CP2-001 page 26
Visual check of painting. Verify absence of damages. Repair if necessary according to painting specification	-	1*	
Functional test	-	1*	PM-CP2 -002 page 27
Functional test by Manual Override	-	1*	PM-CP2 -003 page 28
Check electrical components (if present) and grounding connections	-	1*	PM-CP2 -004 page 29
Cylinder seals replacement (Single-Acting Actuator size 035-045)	-	5*	PM-CP2-005 page 30
Cylinder seals replacement (Single-Acting Actuator size 055-065)	-	5*	PM-CP2-006 page 34
Cylinder seals replacement (Double-Acting Actuator)	-	5*	PM-CP2-007 page 38

(\*) The time between maintenance tasks will vary depending on the medium and service conditions. Refer to End User Plant Preventive Maintenance Program for specific task periodicity.



For SIL applications refer to Safety Manual.

### Corrective Maintenance Task



In case of fault, according to details in section 15, the following operations could be executed by the End User.

MAINTENANCE ACTIVITY	REFERENCE
Actuator fail mode converting	CM-CP2-001 page 41



## 16. Periodic Maintenance

		PM-CP2-001	Page: 1/1
<b>Component:</b> Single-Acting actuator (035-045-055-065 size) Double-Acting actuator	<b>Task:</b> Cleaning		
<b>Equipment, Tools, Materials:</b> Air compressor Project documentation (design and operating pressure values)	<b>Warnings:</b>		
			
<b>Preliminary Operations:</b>			
<b>Description:</b>			
<p> <b>Remove electric and pneumatic supply before proceeding.</b></p> <p>1. Remove dust from actuator external surface by dust rag and by blowing air</p> <p> <b>Do not polish/rub non metal surfaces with a dry cloth. The tools and cleaning procedures must not produce sparks or create adverse conditions in the environment during maintenance operations, so as to prevent potential explosion hazards. Prevent electrostatic charges in potentially explosive areas.</b></p>			



## 16. Periodic Maintenance

PM-CP2 -002		Page: 1/1
<b>Component:</b> Single-Acting actuator (035-045-055-065 size) Double-Acting actuator	<b>Task:</b> Functional test	
<b>Equipment, Tools, Materials:</b> Chronometer Project documentation (required stroke times)	<b>Warnings:</b> 	
<b>Preliminary Operations:</b>		
<b>Description:</b> <b>NOTE: Actuator must be connected to the pneumatic supply to perform the following test.</b> <ol style="list-style-type: none"><li>1. Operate the actuator</li><li>2. Perform the stroke several times by local and remote (if applicable) control</li></ol> <p> <b>Actuator could exhaust medium supply in the atmosphere during normal operation. Wear PPD including breathing device in function of type of medium supply used.</b></p> <ol style="list-style-type: none"><li>3. Verify actuator is correctly working</li><li>4. Note the stroke time(s)</li><li>5. Verify stroke time(s) are as required</li></ol> <p>In case of stroke times out of required range refer to Troubleshooting ID 4, 5 (section 15) to restore.</p>		

## 16. Periodic Maintenance

PM-CP2 -003		Page: 1/1
<b>Component:</b> Mechanical manual override	<b>Task:</b> Manual override functional test	
<b>Equipment, Tools, Materials:</b> Project documentation	<b>Warnings:</b> 	
<b>Preliminary Operations:</b>		
<b>Description:</b>		
<b>Opening operation</b>		
<ol style="list-style-type: none"><li>1. Verify the actuator is not in the completely open position</li><li>2. Move the mechanical manual override according to Manual Override instructions (section 12.3) to bring the actuator in the open position</li><li>3. Verify the actuator reaches the fully open position</li></ol>		
<b>Closing operation</b>		
<ol style="list-style-type: none"><li>1. Verify the actuator is not in the completely closed position</li><li>2. Move the mechanical manual override according to Manual Override instructions (section 12.3) to bring the actuator in the close position</li><li>3. Verify the actuator reaches the fully closed position</li></ol>		
 <b>Before re-starting the actuator with air supply, rotate the jackscrew again so as to set the actuator in its original position. After each use, verify that the manual override has been disengaged before returning to remote operation.</b>		

## 16. Periodic Maintenance

		PM-CP2 -004	Page: 1/1
<b>Component:</b> Electrical components (if present)	<b>Task:</b> Check electrical components (if present) and grounding connections		
<b>Equipment, Tools, Materials:</b> Project documentation	<b>Warnings:</b> 		
<b>Preliminary Operations:</b>			
<b>Description:</b>			
<p> <b>Switch off electric power supply before working on electrical devices.</b>  <b>Read and follow the safety precautions reported in the Manufacturer's Maintenance Manual.</b>  <b>Risk of temporary modification of the component protection.</b></p> <p><b>Use only antistatic clothes.</b></p> <ol style="list-style-type: none"> <li>1. Remove cover from electric components</li> <li>2. Check electric device components</li> <li>3. Verify tightness of terminal blocks</li> <li>4. Verify absence of humidity and oxidation</li> <li>5. Check cable gland seals</li> <li>6. Verify grounding connection and restore if necessary</li> </ol>			

## 16. Periodic Maintenance

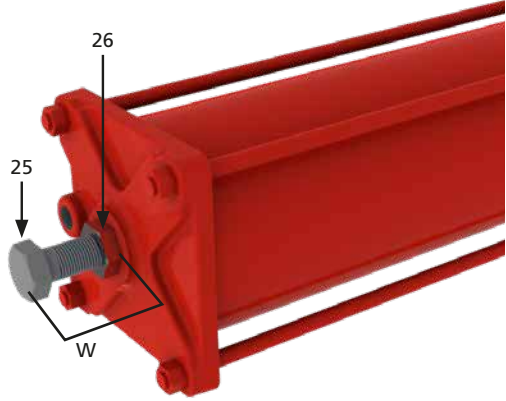
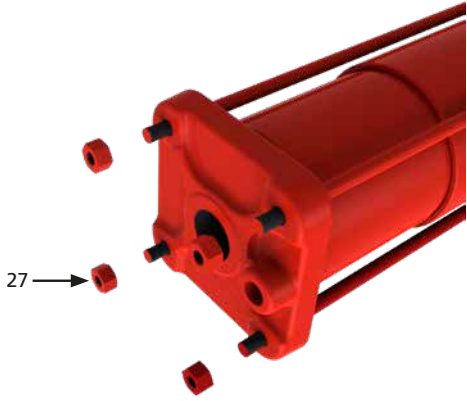
		PM-CP2-005	Page: 1/4
<b>Component:</b> Single-Acting actuator (035-045 size)		<b>Task:</b> Cylinder seals replacement	
<b>Equipment, Tools, Materials:</b> Spare seals Wrench Lifting tools Project documentation		<b>Warnings:</b> 	
<b>Preliminary Operations:</b> Removal from Valve			
<b>Description:</b>			
<p><b>⚠️ Cut-off power supply and electric power supply (if present) before performing any operation.</b></p> <p><b>Preliminary actions</b></p> <ol style="list-style-type: none"> <li>1. Remove actuator from valve (section 11)</li> <li>2. Position the actuator on a workbench (if possible) or in a stable position and in a clean and closed area</li> <li>3. Remove any control equipment (if present). Refer to the project specific documentation</li> <li>4. Remove pneumatic pipes</li> </ol>			
5. Measure length (W)			
6. Hold stop bolt (25) with a wrench and loosen stop nut (26) 7. Fully unscrew stop bolt (25)			
<p>If the stop bolt is hard to unscrew, pressurize the cylinder and unscrew the stop bolt by 3-4 turns.</p> <p>Depressurize the cylinder; check if the stop bolt turns freely. If necessary, repeat the operation.</p> <p><b>⚠️ Do not unscrew the stop bolt completely while the cylinder is pressurized.</b></p>			
8. Unscrew nuts (27)			

## 16. Periodic Maintenance

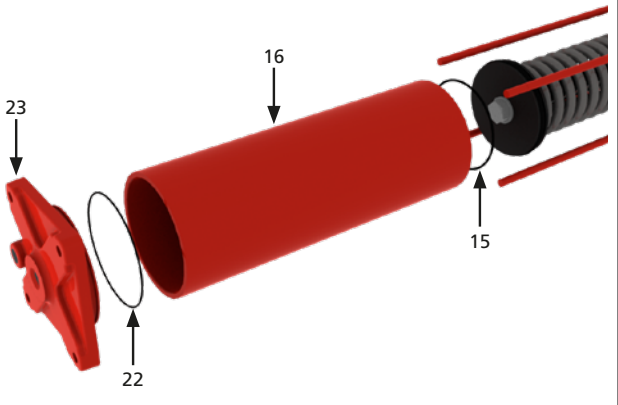
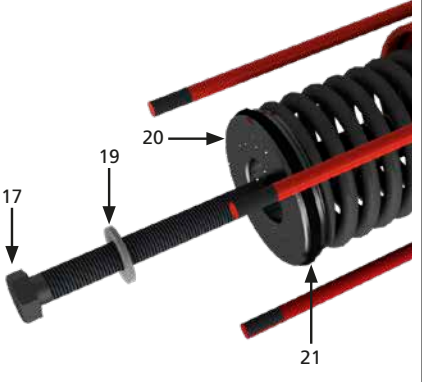
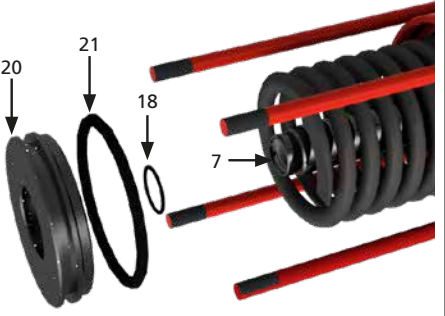
		PM-CP2-005	Page: 2/4
<b>Component:</b> Single-Acting actuator (035-045 size)		<b>Task:</b> Cylinder seals replacement	
<b>Equipment, Tools, Materials:</b> Spare seals Wrench Lifting tools Project documentation		<b>Warnings:</b> 	
<b>Preliminary Operations:</b> Removal from Valve			
9. Remove end flange (23), O-ring (22 and 15) and cylinder tube (16)			
<p><b>⚠ Spring is pre-compressed. With spring fully extended some spring force is still exerted against the piston.</b></p>			
10. Unscrew piston retaining bolt carefully (17) and washer (19)			
<p><b>⚠ If threaded bushing is damaged and/or does not remain fixed to the axial bar, stop the maintenance procedure, reassemble the end flange and contact Rotork.</b></p> <p>11. Remove piston slightly (20) with piston seal (21). Pay attention to the spring that may remain slightly compressed</p> <p>12. Clean O-rings grooves carefully and all sealing surfaces</p> <p>13. All the removed parts should be thoroughly cleaned, inspected and de-burred as necessary</p> <p>14. Replace O-rings and lubricate them with a grease film</p> <p>15. Lubricate with a grease film all moving parts</p>			
16. Install piston (20) with piston seal (21) and O-ring (18) on axial bar (7)			
<p><b>⚠ While disassembling the piston, carefully unscrew piston retaining bolt (17). The piston will automatically follow the bolt during the movement. If not, lightly hit the piston with a suitable tool until the piston joins the bolt. Then proceed with the piston disassembly. Remove the piston carefully. Pay attention to the spring that may remain slightly compressed.</b></p>			

## 16. Periodic Maintenance

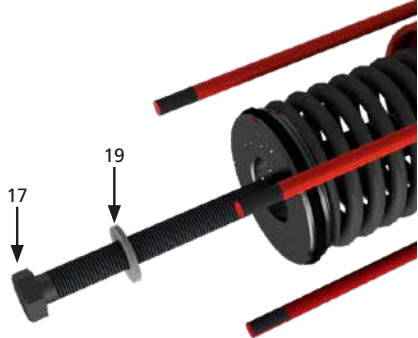
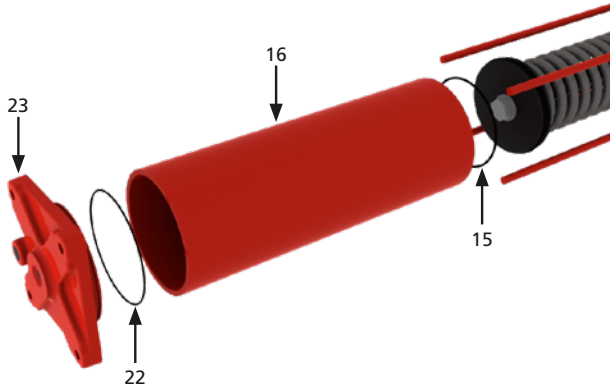
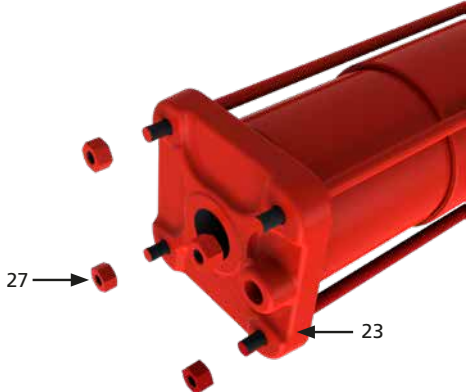
		PM-CP2-005	Page: 3/4
<b>Component:</b> Single-Acting actuator (035-045 size)		<b>Task:</b> Cylinder seals replacement	
<b>Equipment, Tools, Materials:</b> Spare seals Wrench Lifting tools Project documentation		<b>Warnings:</b> 	
<b>Preliminary Operations:</b> Removal from Valve			
17. Install washer (19) and screw bolt (17) <b>⚠ Pay attention to the spring that may remain slightly compressed.</b>			
18. Install cylinder tube (16) with O-ring (15) and (22)			
19. Install end flange (23) 20. Tighten nuts (27) to the recommended tightening torque following a cross bolt torque tightening sequence			

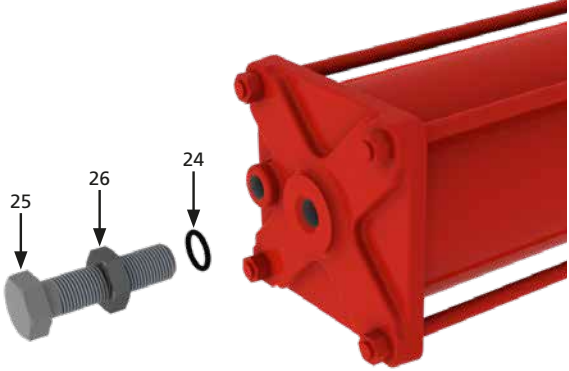

## 16. Periodic Maintenance

PM-CP2-005		Page: 4/4
<b>Component:</b> Single-Acting actuator (035-045 size)	<b>Task:</b> Cylinder seals replacement	
<b>Equipment, Tools, Materials:</b> Spare seals Wrench Lifting tools Project documentation	<b>Warnings:</b> 	
<b>Preliminary Operations:</b> Removal from Valve		
21. Install O-ring (24) 22. Screw stop bolt (25) until reaching length „W“ 23. Hold stop bolt (25) with a wrench and tighten nut (26)		
24. Re-assemble components on actuator 25. Connect pneumatic supply and cycle the actuator several times 26. Verify absence of leakages 27. Verify painted parts and restore if necessary		

## 16. Periodic Maintenance

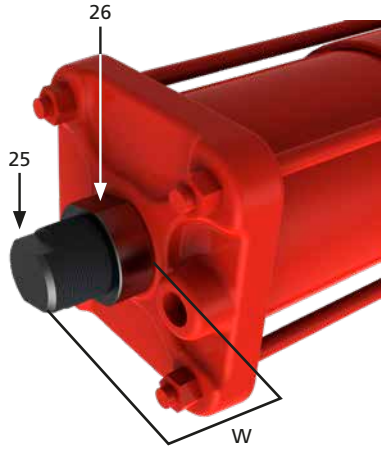
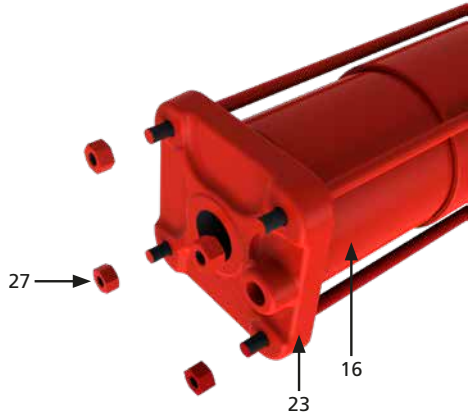
		PM-CP2-006	Page: 1/4
<b>Component:</b> Single-Acting actuator (055-065 size)		<b>Task:</b> Cylinder seals replacement	
<b>Equipment, Tools, Materials:</b> Spare seals Wrench Lifting tools Project documentation		<b>Warnings:</b> 	
<b>Preliminary Operations:</b> Removal from Valve			
<b>Description:</b>			
<p><b>⚠️ Cut-off power supply and electric power supply (if present) before performing any operation.</b></p> <p><b>Preliminary actions</b></p> <ol style="list-style-type: none"> <li>1. Remove actuator from valve (section 11)</li> <li>2. Position the actuator on a workbench (if possible) or in a stable position and in a clean and closed area</li> <li>3. Remove any control equipment (if present). Refer to the project specific documentation</li> <li>4. Remove pneumatic pipes</li> </ol>			
5. Measure length (W)			
<ol style="list-style-type: none"> <li>6. Hold stop bolt (25) with a wrench and loosen stop nut (26)</li> <li>7. Fully unscrew stop bolt (25)</li> </ol> <p>If the stop bolt is hard to unscrew, pressurize the cylinder and unscrew the stop bolt by 3-4 turns.</p> <p>Depressurize the cylinder; check if the stop bolt turns freely. If necessary, repeat the operation.</p> <p><b>⚠️ Do not unscrew the stop bolt completely while the cylinder is pressurized.</b></p>			
<ol style="list-style-type: none"> <li>8. Unscrew nuts (27)</li> <li>9. Remove end flange (23), O-ring (22 and 15) and cylinder tube (16)</li> </ol> <p><b>⚠️ Spring is pre-compressed. With spring fully extended some spring force is still exerted against the piston.</b></p>			

## 16. Periodic Maintenance

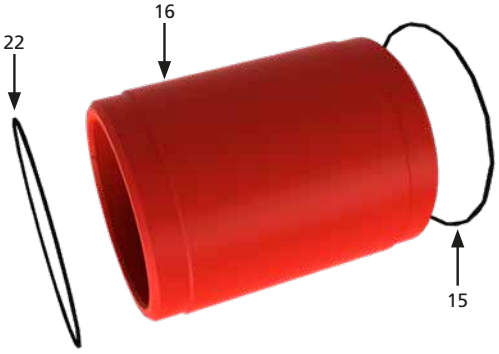
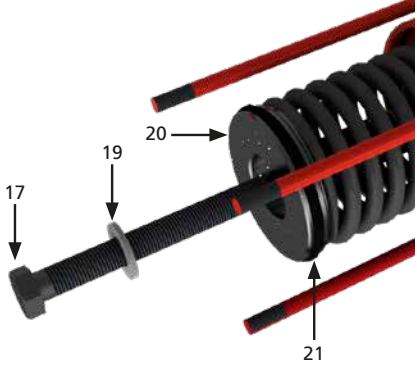
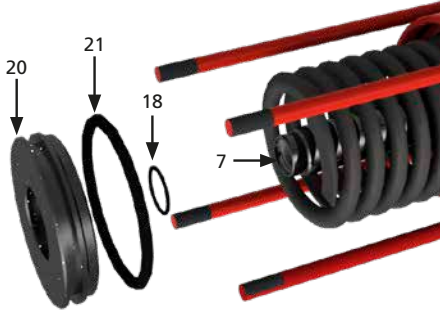
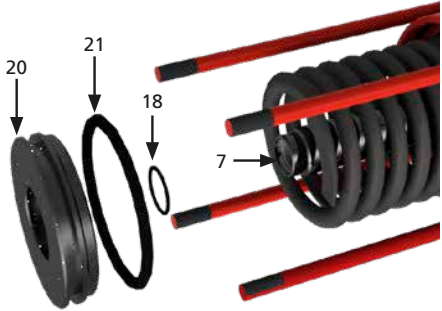
		PM-CP2-006	Page: 2/4
<b>Component:</b> Single-Acting actuator (055-065 size)		<b>Task:</b> Cylinder seals replacement	
<b>Equipment, Tools, Materials:</b> Spare seals Wrench Lifting tools Project documentation		<b>Warnings:</b> 	
<b>Preliminary Operations:</b> Removal from Valve			
10. Remove end flange (23), O-ring (22 and 15) and cylinder tube (16)  <b>⚠ Spring is pre-compressed. With spring fully extended some spring force is still exerted against the piston.</b>			
11. Unscrew piston retaining bolt carefully (17) and washer (19) 12. Remove piston slightly (20) with piston seal (21). Pay attention to the spring that may remain slightly compressed  <b>⚠ If threaded bushing is damaged and/or does not remain fixed to the axial bar, stop the maintenance procedure, reassemble the end flange and contact Rotork.</b>			
13. Remove O-rings (15, 18, 21, 22, 24) 14. Clean O-rings grooves carefully and all sealing surfaces 15. All the removed parts should be thoroughly cleaned, inspected and de-burred as necessary 16. Replace O-rings and lubricate them with a grease film 17. Lubricate with a grease film all moving parts			
18. Install piston (20) with piston seal (21) and O-ring (18) on axial bar (7)  <b>⚠ While disassembling the piston, carefully unscrew piston retaining bolt (17). The piston will automatically follow the bolt during the movement. If not, lightly hit the piston with a suitable tool until the piston joins the bolt. Then proceed with the piston disassembly. Remove the piston carefully. Pay attention to the spring that may remain slightly compressed.</b>			



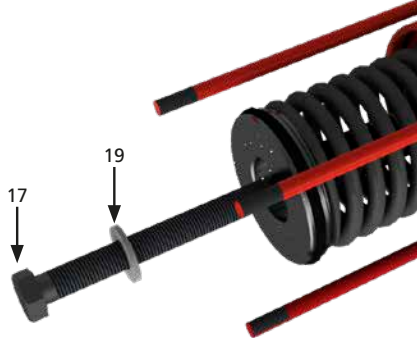
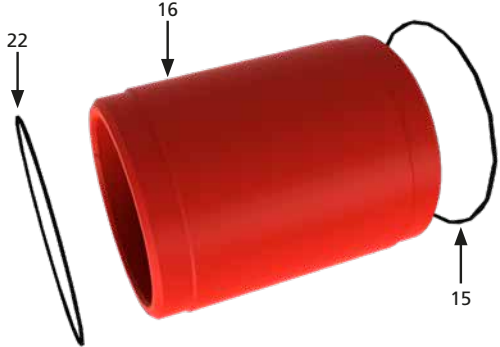
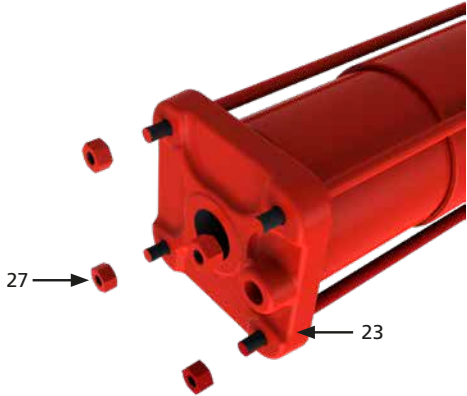

## 16. Periodic Maintenance

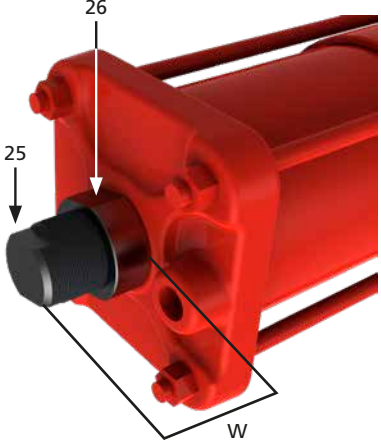
PM-CP2-006		Page: 3/4
<b>Component:</b> Single-Acting actuator (055-065 size)	<b>Task:</b> Cylinder seals replacement	
<b>Equipment, Tools, Materials:</b> Spare seals Wrench Lifting tools Project documentation	<b>Warnings:</b> 	
<b>Preliminary Operations:</b> Removal from Valve		
19. Install washer (19) and screw bolt (17)		
20. Install cylinder tube (16) with O-ring (22) and (15)		
21. Install end flange (23) 22. Tighten nuts (27) to the recommended tightening torque following a cross bolt torque tightening sequence		

## 16. Periodic Maintenance

		PM-CP2-006	Page: 4/4
<b>Component:</b> Single-Acting actuator (055-065 size)	<b>Task:</b> Cylinder seals replacement		
<b>Equipment, Tools, Materials:</b> Spare seals Wrench Lifting tools Project documentation	<b>Warnings:</b> 		
<b>Preliminary Operations:</b> Removal from Valve			
23. Screw stop bolt (25) until reaching length „W“ 24. Hold stop bolt (25) with a wrench and tighten nut (26)			
25. Re-assemble components on actuator 26. Connect pneumatic supply and cycle the actuator several times 27. Verify absence of leakages 28. Verify painted parts and restore if necessary			

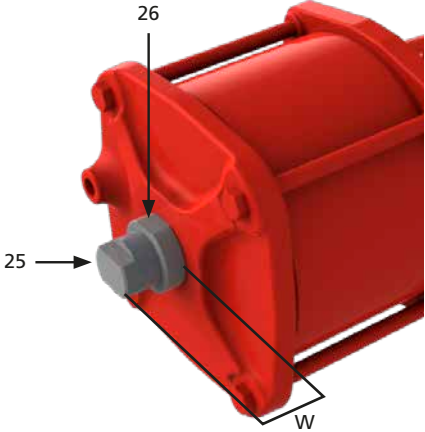
## 16. Periodic Maintenance

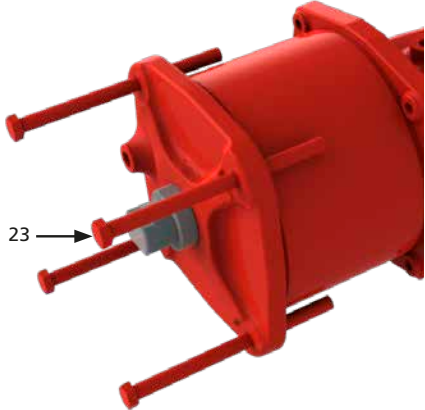
		PM-CP2-007	Page: 1/3
<b>Component:</b> Double-Acting actuator		<b>Task:</b> Cylinder seals replacement	
<b>Equipment, Tools, Materials:</b> Spare seals Wrench Lifting tools Project documentation		<b>Warnings:</b> 	
<b>Preliminary Operations:</b> Removal from Valve			
<b>Description:</b>  <b>Cut-off power supply and electric power supply (if present) before performing any operation.</b>			
<b>Preliminary actions</b> <ol style="list-style-type: none"> <li>1. Remove actuator from valve (section 11)</li> <li>2. Position the actuator on a workbench (if possible) or in a stable position and in a clean and closed area</li> <li>3. Remove any control equipment (if present). Refer to the project specific documentation</li> <li>4. Remove pneumatic pipes</li> </ol>			
5. Measure length (W)			
6. Hold stop bolt (25) with a wrench and loosen stop nut (26) 7. Fully unscrew stop bolt (25)			
 <b>Do not unscrew the stop bolt completely while the cylinder is pressurized.</b>			
8. Unscrew nuts (27)			

## 16. Periodic Maintenance

PM-CP2-007

Page: 2/3

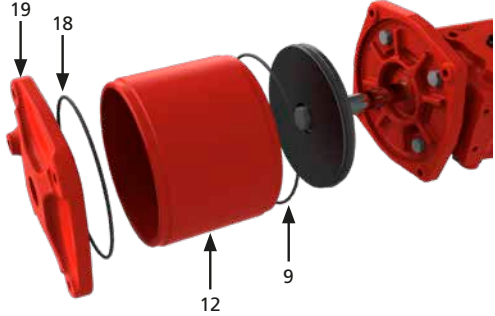
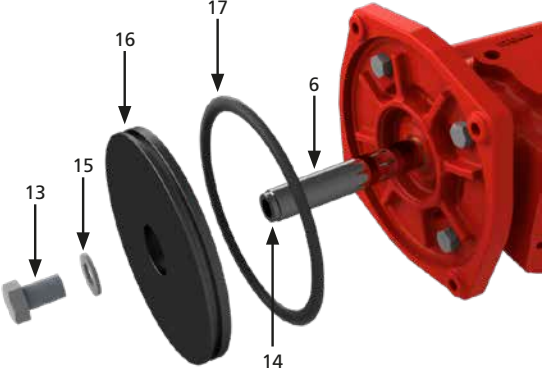
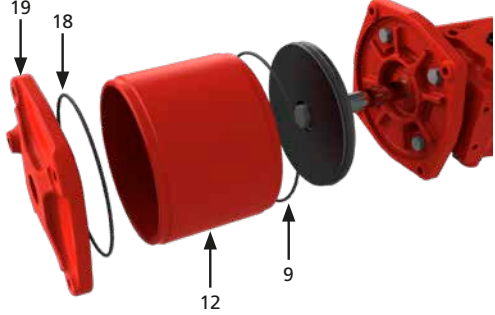

<p><b>Component:</b> Double-Acting actuator</p>	<p><b>Task:</b> Cylinder seals replacement</p>
<p><b>Equipment, Tools, Materials:</b> Spare seals Wrench Lifting tools Project documentation</p>	<p><b>Warnings:</b></p> 
<p><b>Preliminary Operations:</b> Removal from Valve</p>	
<p>9. Remove end flange (19), O-ring (18), cylinder tube (12) and O-ring (9)</p>	
<p>10. Unscrew piston retaining bolt carefully (13) and washer (15) 11. Remove piston (16) slightly with piston seal (17) and O-ring (14) 12. Clean O-rings grooves carefully and all sealing surfaces 13. All the removed parts should be thoroughly cleaned, inspected and de-burred as necessary 14. Replace O-rings and lubricate them with a grease film 15. Lubricate with a grease film all moving parts 16. Install piston on the axial bar (6) 17. Install washer (15) and tighten bolt (13)</p>	
<p>18. Install cylinder tube (12), O-ring (9) O-ring (18) and end flange (19)</p>	

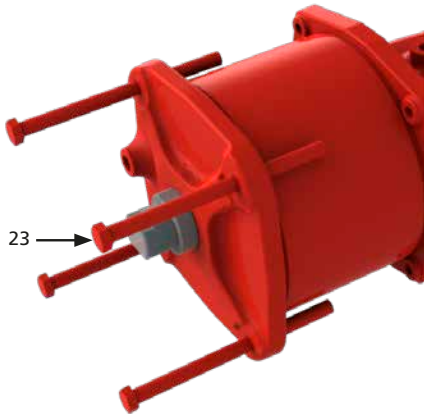
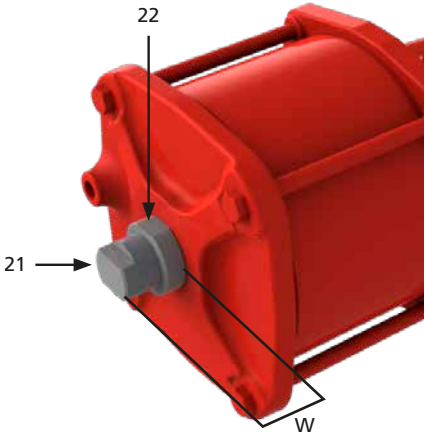
## 16. Periodic Maintenance

		PM-CP2-007	Page: 3/3
<b>Component:</b> Double-Acting actuator	<b>Task:</b> Cylinder seals replacement		
<b>Equipment, Tools, Materials:</b> Spare seals Wrench Lifting tools Project documentation	<b>Warnings:</b> 		
<b>Preliminary Operations:</b> Removal from Valve			
19. Tighten nuts (23) to the recommended tightening torque following a cross bolt torque tightening sequence			
20. Screw stop bolt (21) until reaching length „W” 21. Hold stop bolt (21) with a wrench and tighten nut (22)			
22. Re-assemble components on actuator 23. Connect pneumatic supply and cycle the actuator several times 24. Verify absence of leakages 25. Verify painted parts and restore if necessary			

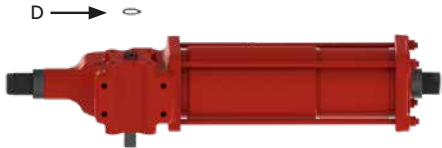
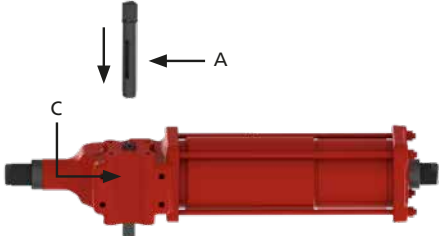
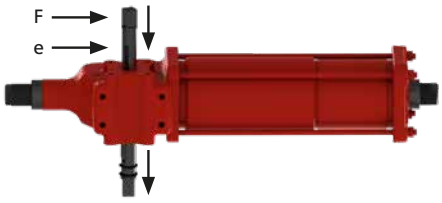

## 16. Periodic Maintenance

		CM-CP2-001	Page: 1/1
<b>Component:</b> Single-Acting actuator (035-045-055-065 size)		<b>Task:</b> Fail mode converting	
<b>Equipment, Tools, Materials:</b> Assembled output shaft (including key and spring) Rubber hammer		<b>Warnings:</b> 	
<b>Preliminary Operations:</b> Removal from Valve			
<b>Description:</b>			
<p><b>⚠ Remove electric and pneumatic supply before proceeding.</b></p> <ol style="list-style-type: none"> <li>Position the actuator on a workbench (if possible) or in a stable position and in a clean and closed area</li> <li>Ensure the actuator is in the fail position, at end of the spring stroke, spring relaxed</li> <li>Remove the limit switch box and its support bracket, if any</li> <li>Remove the control panel if any</li> </ol>			
<ol style="list-style-type: none"> <li>Remove retaining ring (D)</li> <li>Lubricate the new shaft with a grease film</li> </ol>			
<ol style="list-style-type: none"> <li>Place new shaft (A)</li> <li>Assemble the new shaft with the parallel square head rotated by 180° in the yoke (C)</li> <li>With a rubber hammer hit the new shaft, pushing out the old shaft from the yoke</li> </ol>			
<ol style="list-style-type: none"> <li>Insert new spring (E) and key (F)</li> <li>Act on the shaft until it is completely inserted</li> </ol> <p><b>Note: During the shaft insertion, verify that it is correctly engaged and locked.</b></p>			
<ol style="list-style-type: none"> <li>Rotate the actuator by 180° and reassemble retaining ring (D)</li> </ol>			

## 17. Part List

### Single-Acting Actuator (size 035-045)

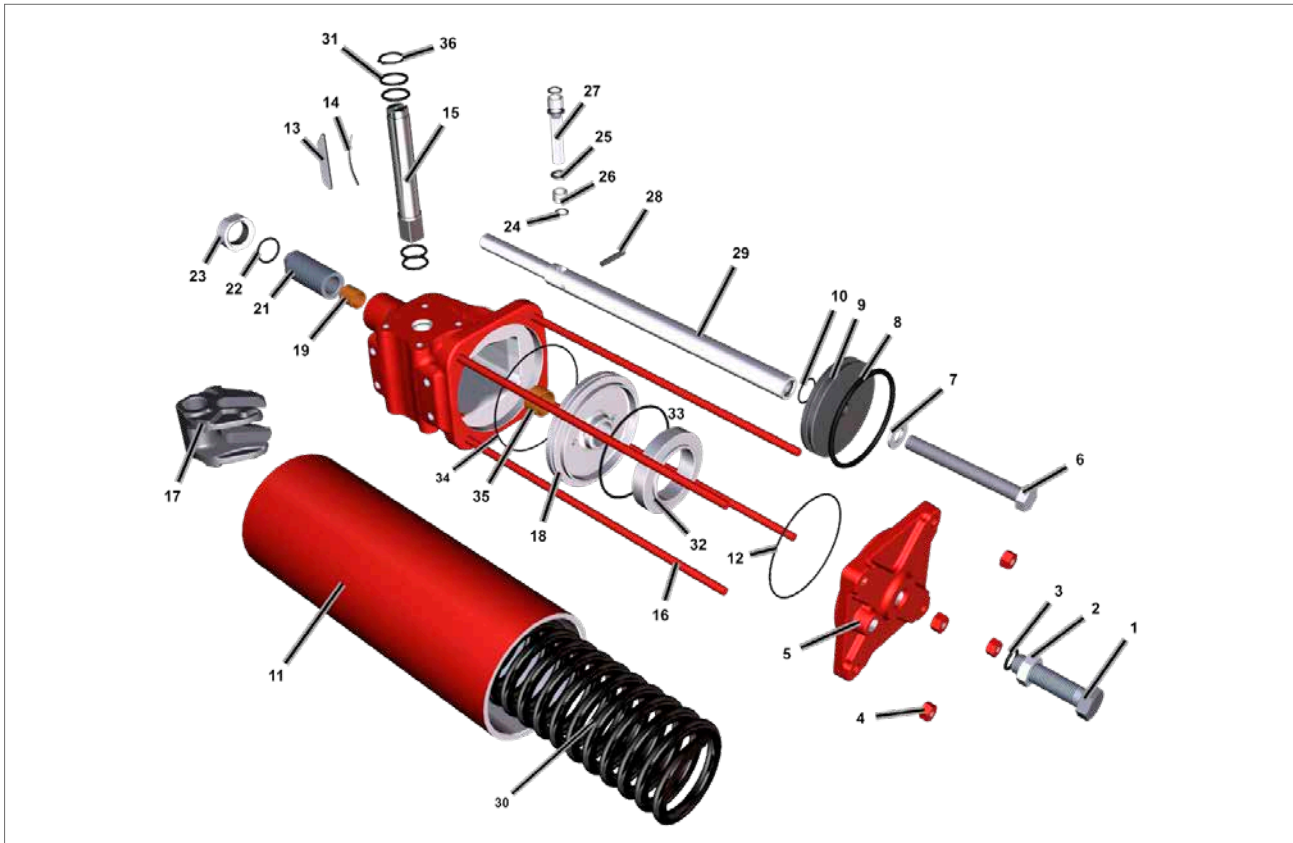

Fig 17.1 Single-Acting Actuator (size 035-045) with adapter disk

ITEM	DESCRIPTION	QTY
1	Stop screw-end flange	1
2	Stop Nut	1
3	O-ring	● 1
4	Hex nut	4
5	End flange	1
6	Hex socket bolt	1
7	Washer	1
8	O-ring	● 1
9	Piston	1
10	O-ring	● 1
11	Cylinder Tube	1
12	O-ring	1
13	Key	1
14	Slotted spring	1
15	Output shaft	1
16	Tie rod	4
17	Scotch Yoke	1
18	Adapter disk	1

ITEM	DESCRIPTION	QTY
19	Sliding bushing	1
20	Center body	1
21	Stop bolt - Center body	1
22	O-ring	● 1
23	Stop nut	1
24	Snap ring	2
25	Shoulder washer	2
26	Bushing	2
27	Yoke pin	1
28	Elastic pin	1
29	Axial bar	1
30	Spring	1
31	O-ring	● 4
32	Spacer (if present))	1
33	O-ring	● 1
34	O-ring	● 1
35	Sliding bushing	1
36	Retaining ring	1

● Recommended spare part

## 17. Part List

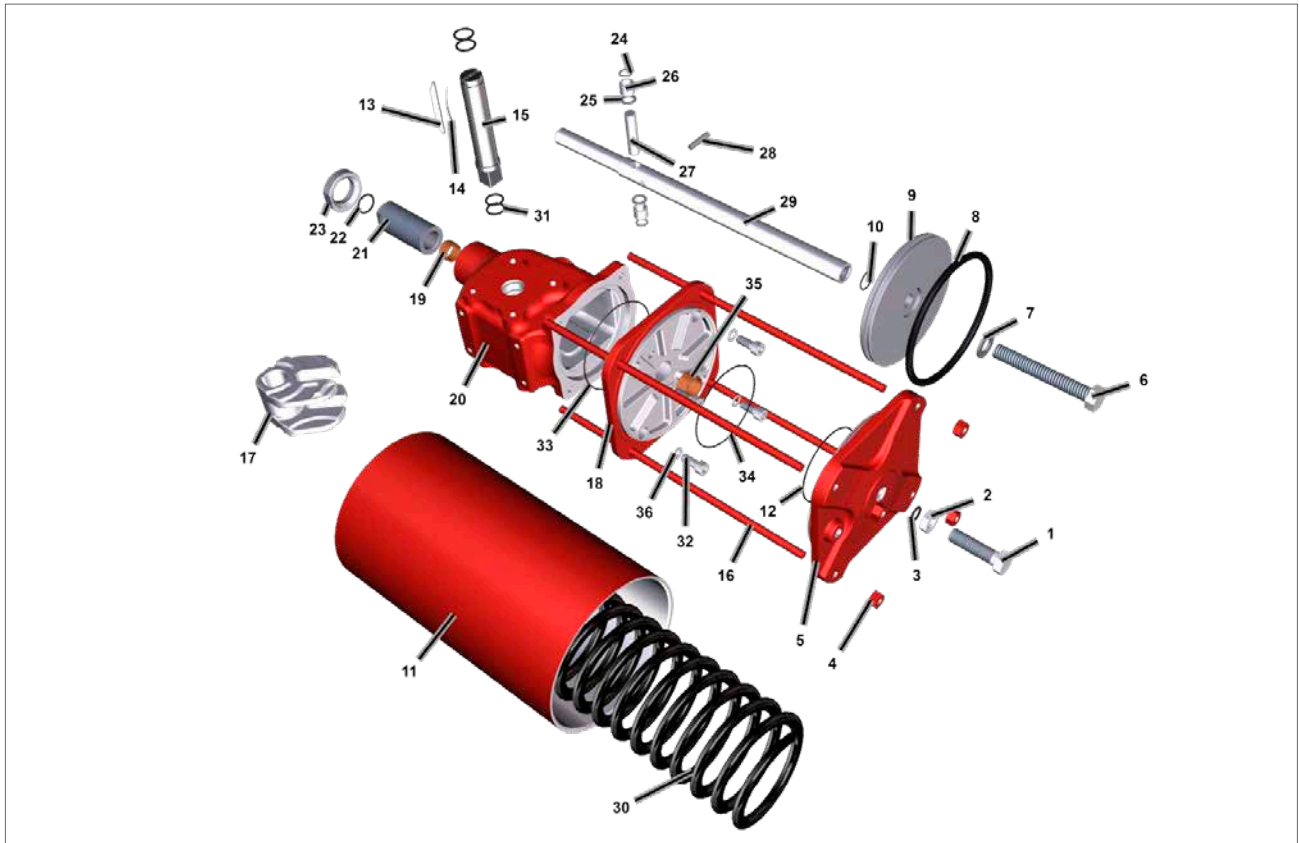

Fig 17.2 Single-Acting Actuator (size 035-045) with adapter flange

ITEM	DESCRIPTION	QTY
1	Stop screw-end flange	1
2	Stop Nut	1
3	O-ring ●	1
4	Hex nut	4
5	End flange	1
6	Hex socket bolt	1
7	Washer	1
8	O-ring ●	1
9	Piston	1
10	O-ring ●	1
11	Cylinder Tube	1
12	O-ring ●	1
13	Key	1
14	Slotted spring	1
15	Output shaft	1
16	Tie rod	4
17	Scotch Yoke	1
18	Adapter flange	1
19	Sliding bushing	1

ITEM	DESCRIPTION	QTY
20	Center body	1
21	Stop bolt - Center body	1
22	O-ring ●	1
23	Stop nut	1
24	Snap ring	2
25	Shoulder washer	2
26	Bushing	2
27	Yoke pin	1
28	Elastic pin	1
29	Axial bar	1
30	Spring	1
31	O-ring ●	4
32	Hex socket bolt	4
33	O-ring ●	1
34	O-ring ●	1
35	Sliding bushing	1
36	Seal washer	4
37	Retaining ring	1

● Recommended spare part

## 17. Part List

### Single-Acting Actuator (size 055-065)

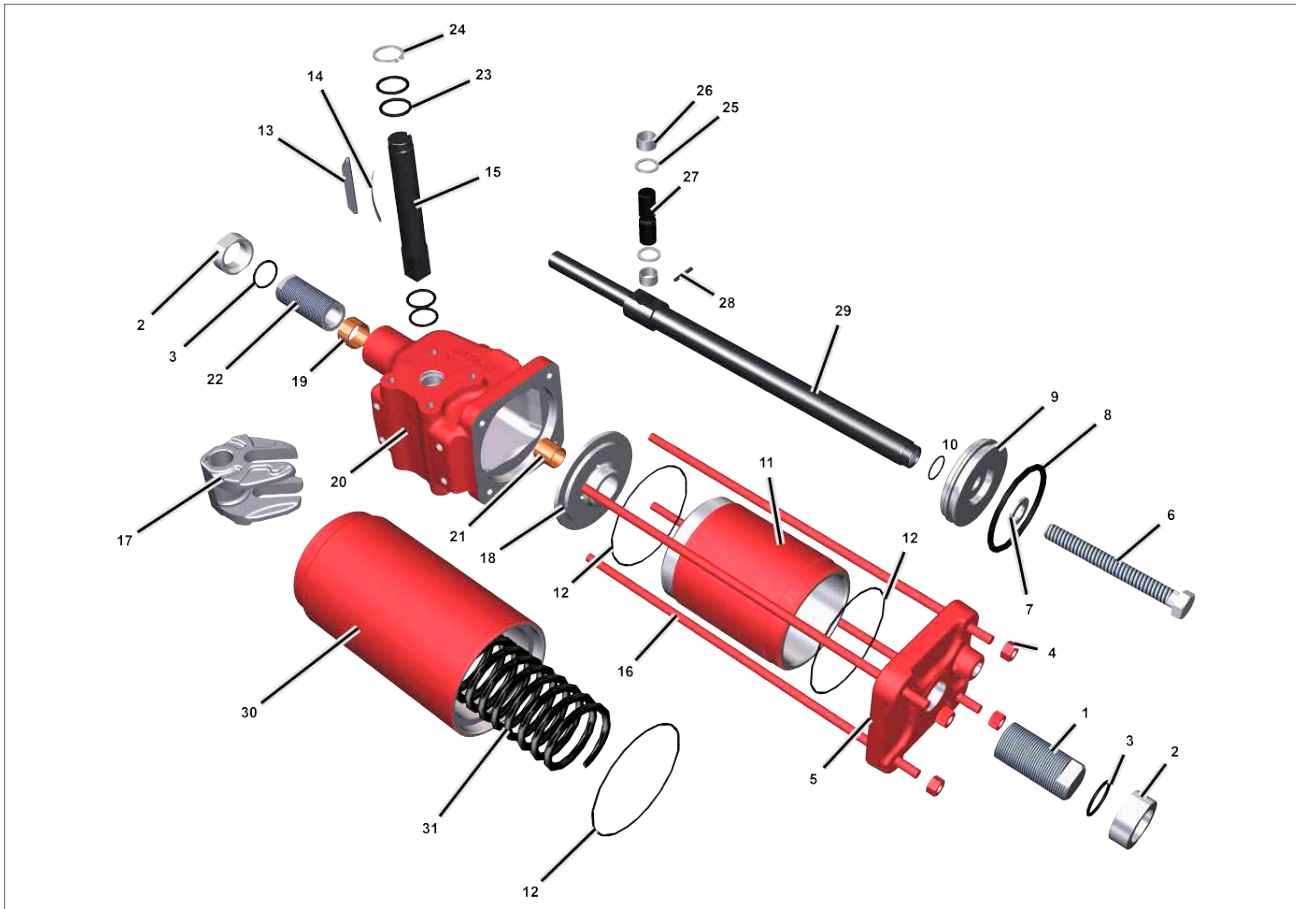

Fig 17.3 Single-Acting Actuator (size 055-065) with adapter plate

ITEM	DESCRIPTION	QTY
1	Stop bolt-end flange	1
2	Stop nut	2
3	O-ring	● 2
4	Hex nut	4
5	End flange	1
6	Hex socket bolt	1
7	Washer	1
8	O-ring	● 1
9	Piston	1
10	O-ring	● 1
11	Cylinder tube	1
12	O-ring	● 3
13	Key	1
14	Slotted spring	1
15	Output shaft	1
16	Tie rod	4

ITEM	DESCRIPTION	QTY
17	Scotch Yoke	1
18	Adapter plate	1
19	Sliding bushing	1
20	Center body	1
21	Sliding bushing	1
22	Stop bolt - Center body	1
23	O-ring	● 4
24	Back-up ring	1
25	Shoulder washer	2
26	Sliding bushing	2
27	Yoke pin	1
28	Elastic pin	1
29	Axial bar	1
30	Spring cartridge	1
31	Spring	1

● Recommended spare part

## 17. Part List

### Double-Acting Actuator

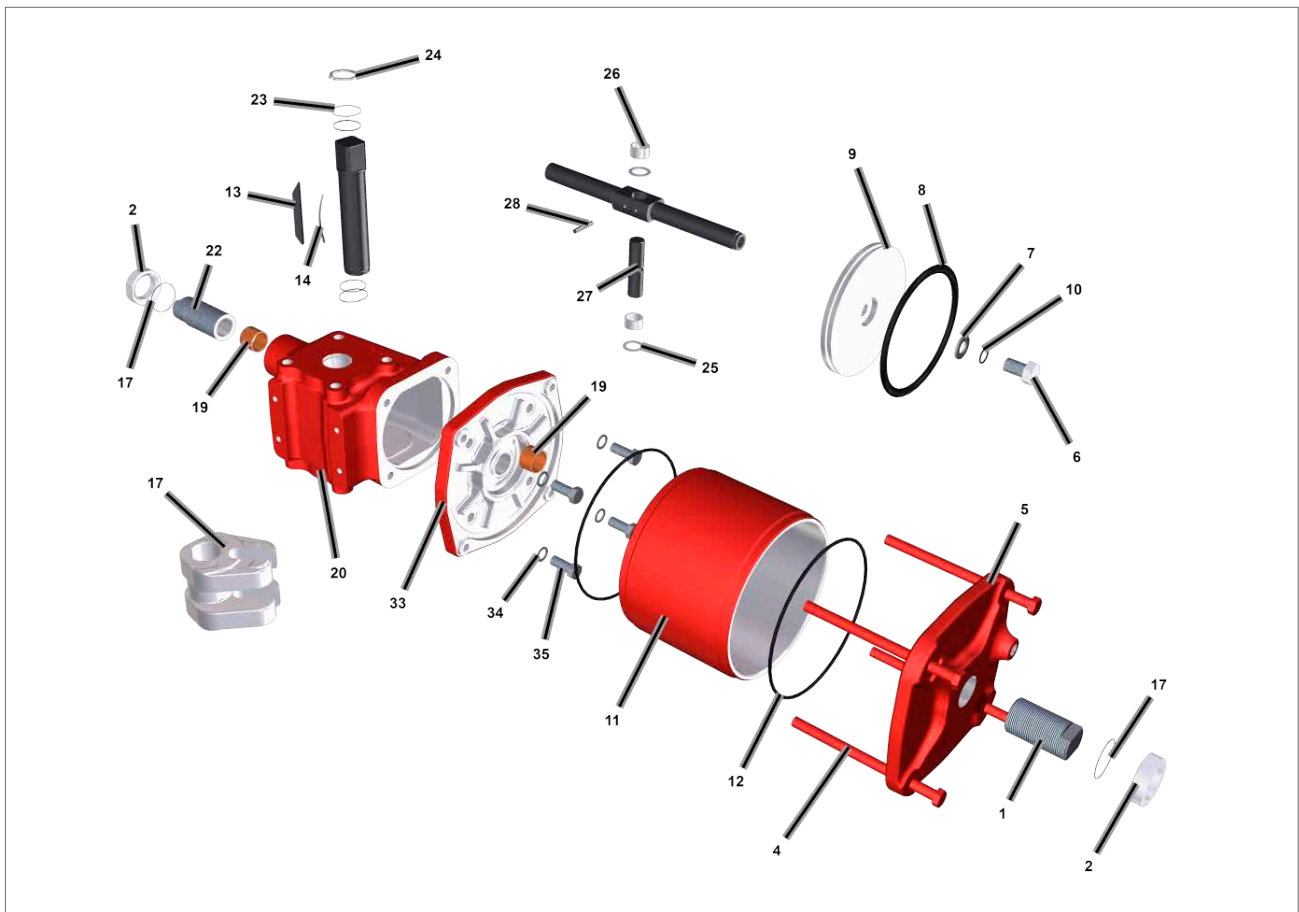

Fig 17.4 Double-Acting Actuator

ITEM	DESCRIPTION	QTY
1	Stop bolt-end flange	1
2	Stop nut	2
3	O-ring	● 2
4	Hex socket bolt	4
5	End flange	1
6	Hex socket bolt	1
7	Washer	1
8	O-ring	● 1
9	Piston	1
10	O-ring	● 1
11	Cylinder tube	1
12	O-ring	● 2
13	Key	1
14	Slotted spring	1
15	Output shaft	1
17	Scotch Yoke	1

ITEM	DESCRIPTION	QTY
19	Sliding bushing	1
20	Center body	1
21	Sliding bushing	1
22	Stop bolt – Center body	1
23	O-ring	● 4
24	Backup ring	1
25	Shoulder washer	2
26	Sliding bushing	2
27	Yoke pin	1
28	Elastic pin	1
29	Axial bar	1
32	O-ring	● 1
33	Adapter flange	1
34	Seal washer	4
35	Hex socket bolt	4

● Recommended spare part

## 17. Part List

### Mechanical Manual Override M-MH

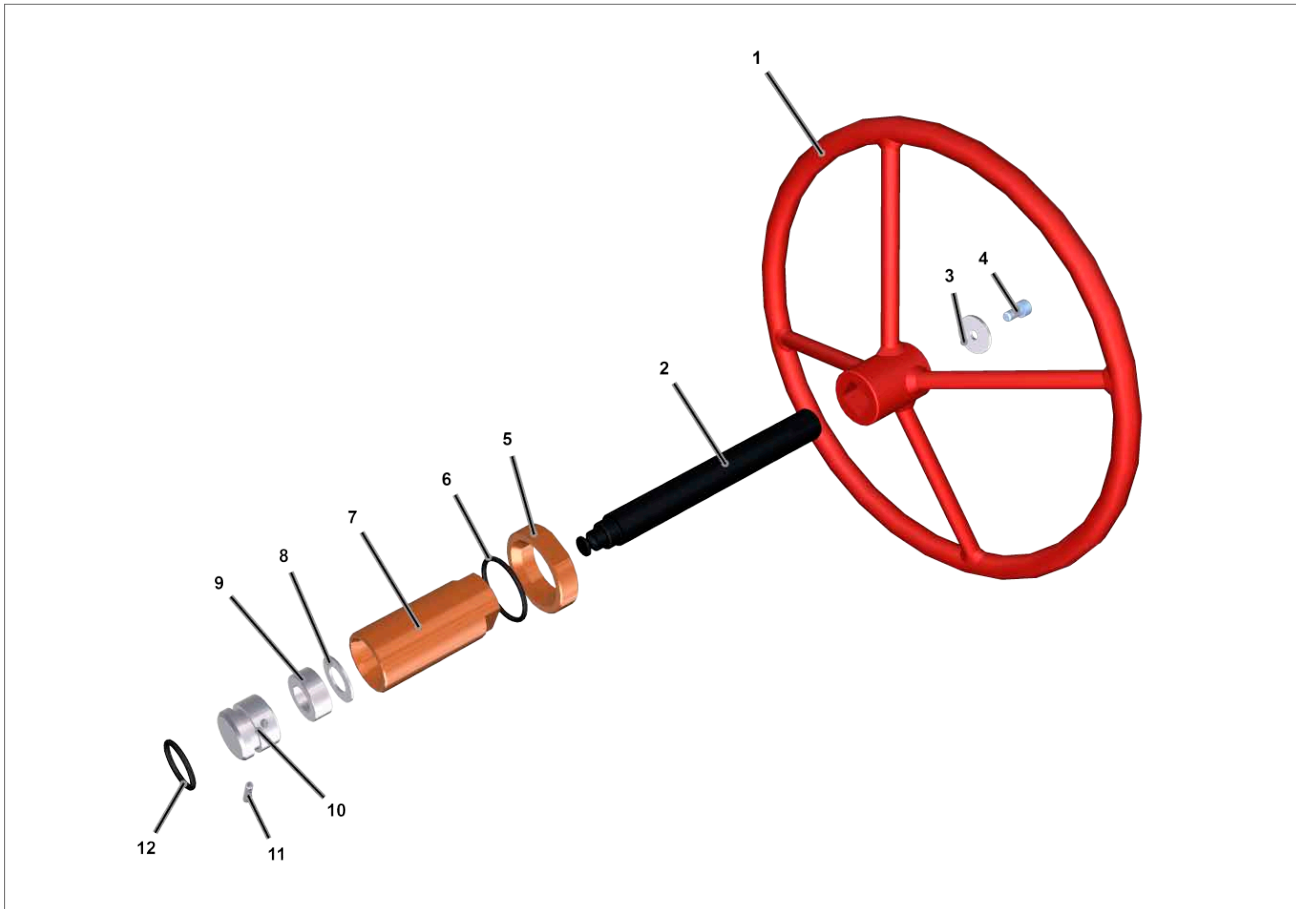

Fig 17.5 Mechanical manual override MHD

ITEM	DESCRIPTION	QTY
1	Handwheel	1
2	Jackscrew	1(*)
3	Washer	1
4	Screw	1
5	Nut	1
6	O-ring	● 1
7	Setting dowel	1
8	Washer	1
9	Bearing	1
10	Front plate	1
11	Slotted spring pin	1
12	O-ring	● 1

● Recommended spare part

(\*) = Left threaded jackscrew for fail to close actuator  
 Right threaded jackscrew for fail to open actuator

## 18. Grease and Hydraulic Oil Specification

In general, there is no need to lubricate the actuator because its mechanism is lubricated for life. The standard grease for Rotork scotch yoke actuators are shown below. If an alternative was specified and/or supplied, please refer to the job specific documentation.

### 18.1 Grease

Lubricate mechanical sliding components of the scotch yoke actuators, output shaft, bushing, manual override and all seals, using the following grease or equivalent:

<b>Manufacturer:</b>	SHELL
<b>Trade name:</b>	GADUS S5 V25Q
<b>NLGI grade:</b>	2.5
<b>Colour:</b>	Clear Brown
<b>Penetration, density, viscosity</b> <b>Viscosity of oil at 40 °C (104 °F) (ASTM D445):</b> <b>Viscosity of oil at 100 °C (212 °F) (ASTM D445):</b>	25 cST 4.8 cST
<b>Temperature Drop point (IP396):</b>	180 °C (356 °F)

QUANTITY OF GREASE IN HOUSING	
Center body size	Qty (kg)
035	0,06
045	0,06
055	0,08
065	0,08

# rotork®



[www.rotork.com](http://www.rotork.com)

A full listing of our worldwide sales and service network is available on our website.

Rotork plc  
Brassmill Lane, Bath, UK  
tel +44 (0)1225 733200  
email [mail@rotork.com](mailto:mail@rotork.com)

PUB013-015-00  
Issue 10/20

All Rotork actuators are manufactured under a third party accredited ISO9001 quality assurance programme. As we are continually developing our products, their design is subject to change without notice.  
The name Rotork is a registered trademark. Rotork recognises all registered trademarks. Published and produced in the UK by Rotork. POWTG0121