

The IW - High Torque Duty quadrant worm operators have been designed to suit isolating duty motorised applications. The new IW High Torque Duty gearbox is inherently self-locking with increased rated torque.

The gearboxes feature a removable output sleeve to facilitate bore and keyway machining, and an indexable baseplate to allow on- or off-centre mounting to the valve stool without special machining. The gearboxes include main gear componentry designed to be inherently self-locking and have been comprehensively tested to ensure structural safety under all actuator operating conditions, test reports available on request.

Operating temperature normally ranges from -40 to +120 °C, although other temperature ranges are available on request. Standard actuated input and output flanges are to ISO 5211 standard. However, equivalent standards such as MSS & DIN can also be supplied.

Application

Rotork IW - High Torque Duty gear operators are part-turn devices intended for the operation of ball, plug and butterfly valves. The gearboxes are suitable for motorised applications.

Features

- Totally enclosed gearing
- Grease filled for life & fully sealed to IP67 as standard
- Comprehensive gear ratios combined with a selection of auxiliary input spur gear reducers
- Angular contact bearings supporting worm shaft
- Removable and repositionable output sleeve
- Repositionable baseplate facility
- Adjustable mechanical stops (at 0° and 90° ±5°)
- Inherently self-locking gear componentry

IW - High Torque Duty

High Torque Part-Turn Worm Gear Operator

Environmental Specification

- IP67 as standard:
Suitable for submerged duty up to a depth of 1 metre for 30 minutes
- IP68 option:
Suitable for submerged duty up to a depth of 15 metres for 72 hours
- Temperature as standard:
-40 to +120 °C (-40 to +250 °F)

Options

- Flexible extensions
- IP68
- ATEX
- All types of environment
- Low temperature option:
-60 °C (-76 °F)
- High temperature option:
+200 °C (+392 °F)

IW High Torque Duty

Material Specification

Component	Material	UK Standard	USA Standard	DIN Standard	ISO Standard
Gearcase	SG Iron	BS1563 EN-GJS-450-10 BS1563 EN-GJS-400-15	ASTM A536 65-45-12	GGG40	ISO 1083 JS 450-10 ISO 1083 JS 400-15
Baseplate	SG Iron Cast Iron	BS1563 EN-GJS-450-10 BS1561 EN-GJL-250	ASTM A536 65-45-12 ASTM A48 35B/40B	GGG40 GG25	ISO 1083 JS 450-10 ISO 185 JL/250
Worm Shaft	Steel	BS970 708M40	AISI/SAE 4140	42 CrMo 4	ISO 683 42 CrMo 4
Quadrant	SG Iron	BS1563 EN-GJS-700-2	ASTM A536 100-70-03	GGG70	ISO 1083 JS 700-2
Position Indicator	Steel	BS970 070M20	AISI/SAE 1023	C 22	ISO 683 C 20
Output Sleeve	Steel	BS970 070M20 BS970 080M40 BS970 070M55	AISI/SAE 1023 AISI/SAE 1040 AISI/SAE 1055	C 22 C 40 C 55	ISO 683 C 20 ISO 683 C 40 E4 ISO 683 C 55 E4
Fasteners	Protected Steel	BS3692			
Input Flange	SG Iron	BS1563 EN-GJS-450-10 BS1563 EN-GJS-400-15	ASTM A536 65-45-12	GGG40	ISO 1083 JS 450-10 ISO 1083 JS 400-15
Reducer Gearing	Steel	BS970 817M40T	AISI/SAE 4340	34 CrNiMo 6	ISO 683 36 CrNiMo 6
Reducer Gearcase	SG Iron	BS1563 EN-GJS-450-10 BS1563 EN-GJS-400-15	ASTM A536 65-45-12	GGG40	ISO 1083 JS 450-10 ISO 1083 JS 400-15
Bearings	Angular Contact Ball Bearings				
Seals	Nitrile Rubber				
Grease	Renolit CLX2				

*Materials of construction are those listed above or equivalents

Input and Output Options

Gearbox	Ratio	Input Mounting Details Shaft Diameter (mm)					Output Mounting Details			
		F10	F14	F16	F25	F30	Max Bore Rectangle Key BS4235	Max Square Bore A/F	ISO Flange Standard Baseplate	ISO Flange Large Baseplate
IW3	70	15*	-	-	-	-	45	36	F10 - F12	F14 - F16
IW4	70	17*	-	-	-	-	64	51	F10 - F12 - F14	F16
	140 to 420	20	20	-	-	-				
IW5	40, 48	20	25	-	-	-	76	62	F14 - F16	F25
	80 to 240, 96 to 288	20	20	-	-	-				
IW6	76	20	30	30	-	-	102	83.3	F16 - F25	F30
	152 to 456	20	20	-	-	-				
IW7	64	20	30	30	30	-	136	108.8	F25 - F30	F35
	130 to 768	20	30	-	-	-				
IW8	64	-	-	40	40	-	157	122.9	F25 - F30 - F35 - F40	F48
	130 to 768	20	30	40	50	-				
IW9	58	-	-	40	50	-	178	132.1	F30 - F35 - F40	F48
	174 to 2900	20	30	40	50	-				
IW10	74	-	-	-	50	50	203	152.6	F35 - F40 - F48	F60
	222 to 3700	20	30	40	50	-				
IW11	73	-	-	-	50	50	203	152.6	F35 - F40 - F48	F60
	439 to 6560	20	30	40	50	-				
IW11BB	73	-	-	-	50	50	270	190	F40 - F48	F60
	439 to 6560	20	30	40	50	-				
IW12, IW13	70	-	-	-	75	75	272	180	F35 - F40 - F48	-
	280 to 1120	-	30	40	50	-				
	1505 to 6720	20	30	30	-	-				
IW12, IW13	70	-	-	-	75	75	305	229	F48 - F60	-
	280 to 1120	-	30	40	50	-				
	1505 to 6720	20	30	30	-	-				

* 20 mm shaft adaptor available on request. Shaft tolerance -0.05 (-0.002")

IW High Torque Duty

Dimensions

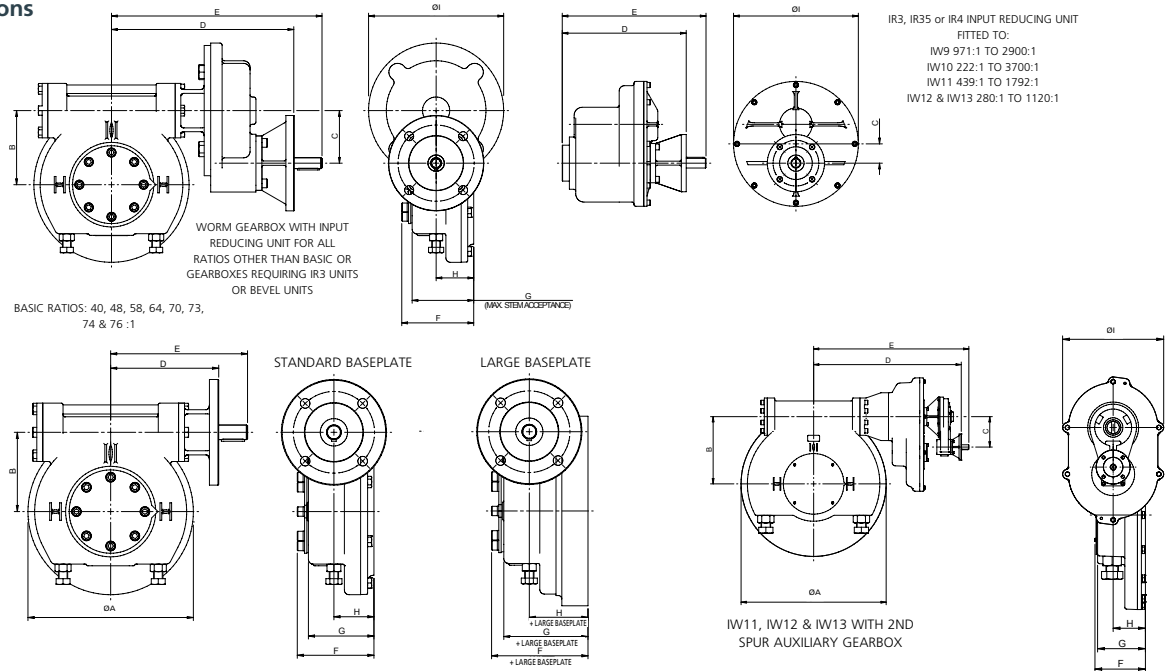

Gearbox	Ratio	ØA	B	C	D	E	F	G	H	ØI	Large Baseplate Thickness
IW3	70	172	76		118	158	91	74	49		22
IW4	70	218	102		142	182	102	85	50		25
	140 - 280	218	102	64	269	320	104	85	50	190	
IW5	355 - 420	218	102	96	291	342	104	85	50	248	6
	40, 48	285	136		186	236	132	114	69		
IW6	80, 96, 120, 144, 160, 192	285	136	64	313	364	132	114	69	190	0
	203, 240, 243, 288	285	136	96	335	386	132	114	69	248	
IW7	76	375	178		186 (196 for F/FA10)	236	139	113	70		31
	152 - 304	375	178	64	313	364	139	113	70	190	
IW8	385 - 456	375	178	96	342	393	139	113	70	248	38
	64	450	210		270	329	171	140	86		
IW9	130 - 384	450	210	119	460	521	171	140	86	290	27
	505 - 768	450	210	179	469	530	171	140	86	408	
IW10	64	520	246		306	365	192	160	99		32
	130 - 384	520	246	119	496	557	192	160	99	290	
IW11 / IW11BB	505 - 768	520	246	179	505	566	192	160	99	408	0
	58	596	279		371	481	200	168	99		
IW12, IW13	174 - 696	596	279	179	568	631	200	168	99	408	0
	971 - 2900	596	279	59	605	666	200	168	99	382	
IW12 with 2nd spur auxiliary	74	735	343		397	507	216	180	110		-
	222 - 3700	735	343	59	631	692	216	180	110	382	
IW13 with 2nd spur auxiliary	73	795	381		414	524	247	200	120		-
	439 - 6560	795	381	59	648	709	247	200	120	382	
IW12, IW13	70	972	450		460	610	260	251	166		-
	280 - 1120	972	450	240	851	910	260	251	166	520	
IW12 with 2nd spur auxiliary	1505 - 6720	972	450	204	989	1039	260	251	166	520	-
IW13 with 2nd spur auxiliary	1505 - 6720	972	450	305	1001	1051	260	251	166	520	-

All dimensions in mm.

