

rotork®

Controls

AWT Range



Watertight 3-phase
Electric Valve Actuator

Redefining Flow Control

Contents

rotork® Controls

Section	Page
Product Overview	3
Application	4
Reliability Through Sealing	4
Reliability Through Control	5
Reliability Through Design	6
Mechanical Specification and Certification	8
Electrical Specification and Certification	9
Mechanical Summary	10
Performance Summary	11



Rotork is the global market leader in valve automation and flow control. Our products and services are helping organisations around the world to improve efficiency, assure safety and protect the environment.

We strive always for technical excellence, innovation and the highest quality standards in everything we do. As a result, our people and products remain at the forefront of flow control technology.

Uncompromising reliability is a feature of our entire product range, from our flagship electric actuator range through to our pneumatic, hydraulic and electro-hydraulic actuators, as well as instruments, gear boxes and valve accessories.

Rotork is committed to providing first class support to each client throughout the whole life of their plant, from initial site surveys to installation, maintenance, audits and repair. From our network of national and international offices, our engineers work around the clock to maintain our position of trust.

Rotork. Redefining flow control.

Product Overview

This brochure provides a comprehensive overview of the applications and associated functions available with Rotork AWT actuators.

Our involvement can go further than just providing the actuator. We can also supply the gearbox, valve adaption kits and control systems to complement it.

Well equipped, Rotork-trained engineers, technicians and representatives working worldwide offer both on-site and factory service. Specialist teams offer preventative maintenance and retrofit valve motorisation backed by a quick responsive service. Our aim is to provide our customers with service excellence.

Electric actuators provide the means of applying centralised control to valves, sluice gates and dampers. As part of the process routine or in an emergency, where there is risk to life, the environment or damage to plant, operational reliability of the valve is essential.

The actuator is the meeting point of the three elements of process control – valve, electrical power and control instrumentation. Each element has unique engineering requirements, brought together with design excellence at the interface – the AWT actuator.

Through design, development and production, actuators are tested to the limit. Design life testing, environmental, vibration as well as electrical testing are all carried out. Every unit is production proven on test rigs to check torque, electrical and mechanical operation and customer control and indication interface.



Application

AWT - Reliability through simplicity

At the hub of process control, Rotork understand that the actuator is fundamental to process reliability. Our recognised design excellence in actuation has led to the AWT - a reliable, rugged yet simple design.

The basics

Actuator torque and thrust plus operating time must be defined and guaranteed for life. Position limit and torque settings must be fixed and repeatable. Valve torque sealing and protection has to be reliable if the valve is to do its job and isolate every closure.

Actuators located in extreme environments such as hot and cold ambient temperatures, high humidity, spray, flooding, chemical attack or vibration must be protected and go on performing year after year.

Electrical and instrumentation control gear must be designed to cope with regular and infrequent operation typical for valve duties, plus be suitable for upgrade should control or indication philosophies change.

Actuator maintenance tasks should be minimised and even eliminated, freeing site engineers to look after other site equipment.

Standardisation - engineering simplicity

In bringing together the valve, power and control system it is important that the actuator minimises plant design engineering, reducing time, installation costs and simplifying commissioning.

AWT features include:

- Standard mounting interface for valve connection
- Standard motor control schemes for electrical power
- Standard electrical control circuit irrespective of valve type
- Standard instrumentation interface
- Standard commissioning procedure for all valve types

Reliability through Sealing

Protection - the key

Vast experience in the application of electric actuators has enabled Rotork to lead the world in actuator environmental protection. Situated in environments ranging from desert to tundra, marine and underground, where flooding, humidity and corrosive atmospheres are normal, actuators have to perform unflinchingly. Rotork understand that the most important factor affecting the reliability of an actuator is protection from the environment – in simple terms, the integrity of its enclosure.

Ineffective cover or cable gland sealing allows breathing – a process where moisture is drawn into the enclosure forming condensation, the result of air exchanges caused by the expansion and contraction of air within the enclosure. Actuator failure will result – sooner rather than later.

AWT – watertight, non breathing, double-sealed

Rotork AWT range actuators do not breathe. They are double-sealed*, watertight and dust tight rated IP68 - IEC60529, NEMA 4, 4X & 6, suitable for submersion to a depth of 7 metres for 72 hours.

Reliability through double-sealing

Double-sealing is a means whereby the conduit entry and terminal compartment is completely sealed from the motor, control and switching compartments of the actuator. Should the cover be left off during installation or a defective cable gland or conduit allow water into the terminal compartment, the rest of the actuator remains fully protected. Without double-sealing, investment in modern sophisticated controls can be rendered worthless as moisture and dirt ingress will cause actuator failure.

Some other manufacturers try to imitate double-sealing by using sealed limit switches. With this design approach, while limit switches are protected, contactors, relays, heaters and travel measurement mechanisms are not, resulting in actuator failure.

* Option for AWT 10A – 35A SyncroSET.

Rotork Double Sealing Solution compared to other 'sealed' designs

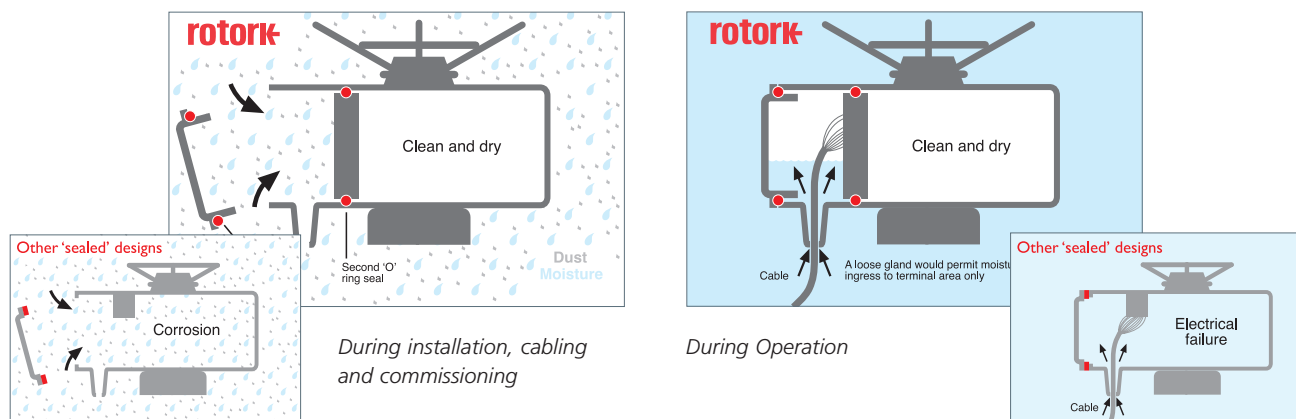

Reliability through Control

Integral motor control – AWT SyncroPAK

AWT SyncroPAK actuators incorporate the motor starter and local controls, with considerable economy to site wiring as shown below.

The SyncroPAK arrangement allows the essential elements of the valve control system to be factory tested and sealed prior to actuator despatch.

The valvemaker can carry out valve testing, requiring only a 3-phase power supply. Factory acceptance testing of the motorised valve can be simply carried out with no risk of incorrect motor control wiring causing valve or actuator damage.

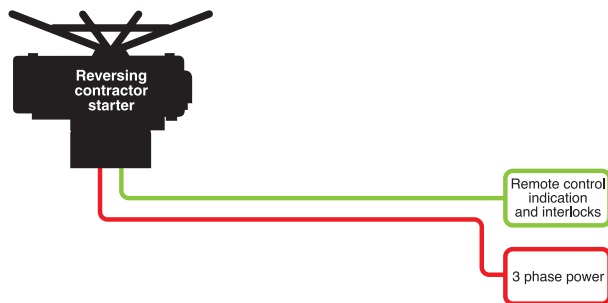

Non-Integral motor control - AWT SyncroSET

Where a new installation requires motor control from the users Motor Control Centre (MCC), or existing installations already incorporating a MCC, the AWT SyncroSET provides the basic components for valve actuation.

Limit switches, indication contacts, optional local control station and motor supply wiring are brought out to the actuators terminal compartment ready for integrating into the MCC control system as shown below.

SyncroSET actuators are particularly suitable for installations where equipment at the valve location must be minimised, for example where high ambient temperature, vibration or space restrictions are present.

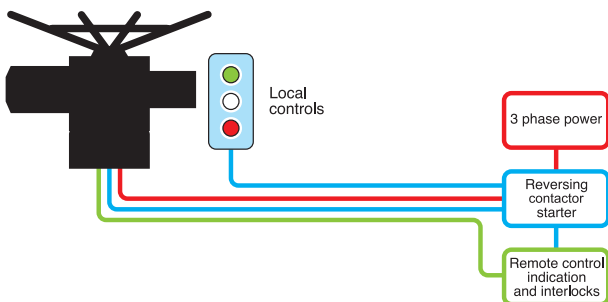

Valve control - reliability to the limits

At the heart of reliable valve control is the ability of the actuator to move on demand and, as important, to stop at the exact position needed for valve sealing. Position limit switches must be 100% reliable and repeatable. Position indication to the control centre must exactly reflect valve status. Torque protection for the valve must be easily selectable by both valvemaker and site maintenance personnel.

The AWT switch mechanism has been doing this job with complete reliability over 50 years. The unique design allows simple limit set-up by screw adjustment for turns, and selectors for independent torque overload setting and "torque" or "position limit" valve seating. The standard latch mechanism prevents both torque switch "hammer" when seating and torque trip during unseating of sticky valves.



Valve control – a difficult problem made simple:

- Standard actuator control circuits irrespective of valve type
- Standard set up procedure for all valve types
- Built in torque, anti-hammer and sticky valve protection
- Once set, limits do not "slip" or "wander"
- 2 normally closed and 2 normally open volt free contacts for end of travel valve status indication

Reliability through Design

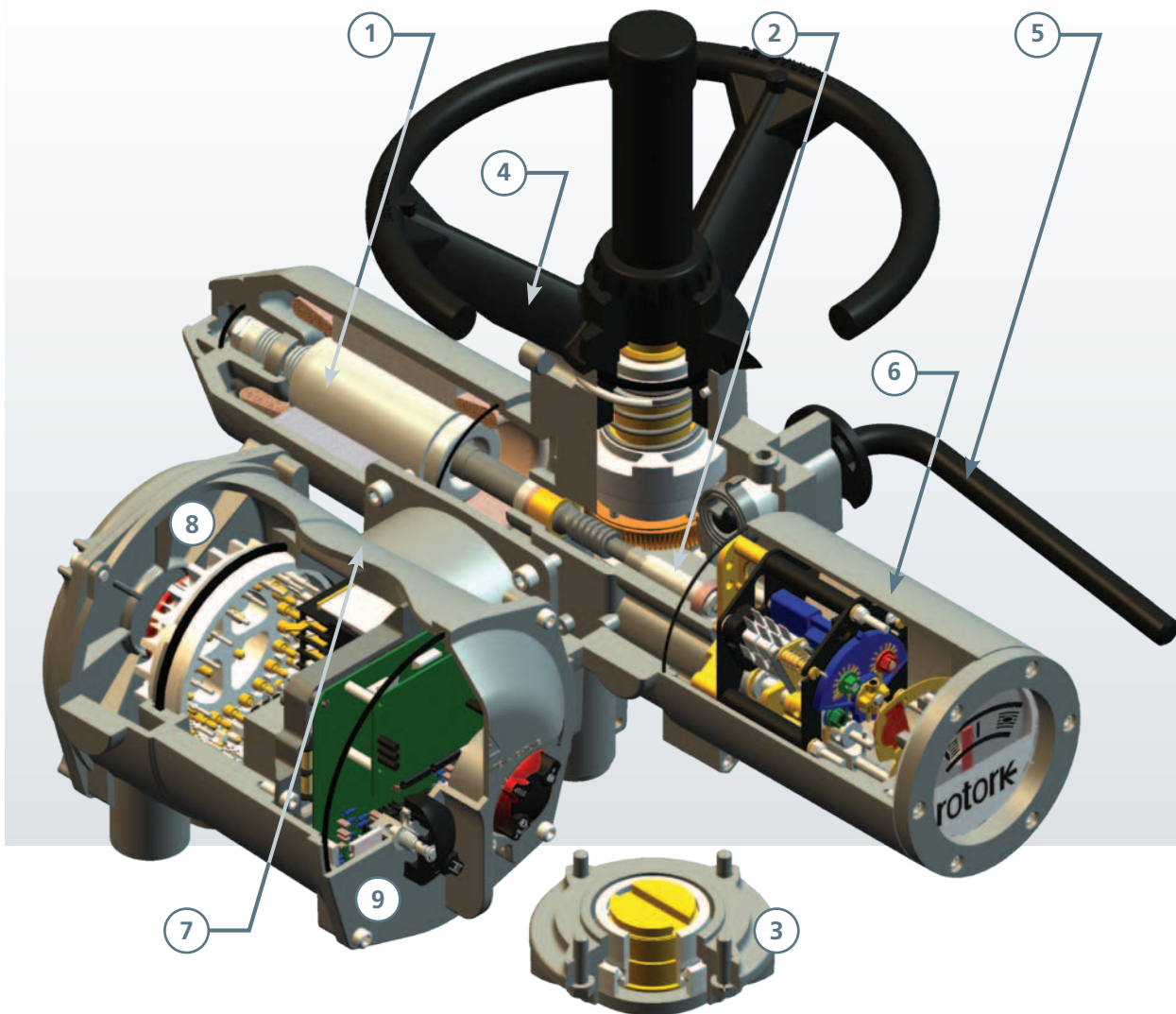

AWT – unique design for a unique application

The AWT comprises components designed specifically for valve control and nothing else. Whether a gate, globe - rising or non rising valve or a quarter-turn ball, butterfly or damper valve, the AWT is matched to them all.

Rotork understand that for valve control an actuator requires dedicated design and high specification. Off the shelf components, while reducing cost are a poor compromise.

By designing and specifying all components Rotork are able to supply the most reliable, cost competitive valve actuation.

We don't stop at just designing the actuator - customer support gets our full design attention.

Service matters

Reliable actuation begins at the planning and specifying stage – getting the right actuator for the job. At the hub of process control, Rotork are in the central position to provide before and after sale technical advice and assistance.

Our unrivalled global network of offices and service centres support customers in every territory. From help with specification detail and sizing to installation, commissioning, service backup and training, you are never alone with a Rotork actuator.

Our dedicated Control Systems, Valve Systems and Electrical and Mechanical Application Engineers provide the technical resource vital for successful valve control.

Reliability through Design

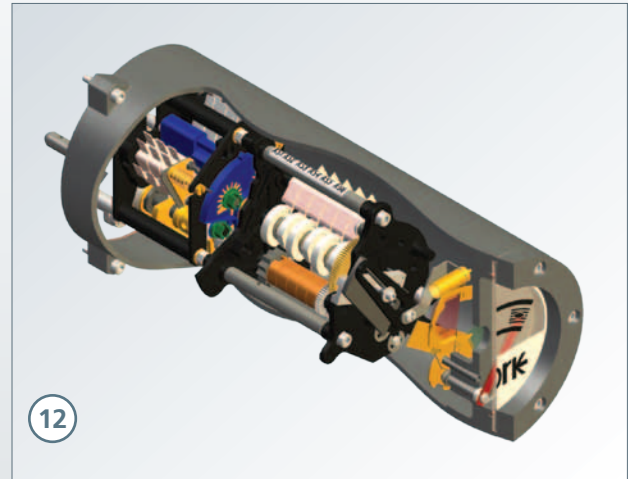
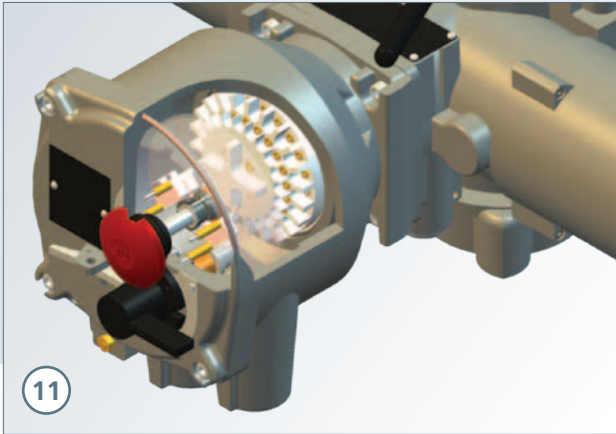
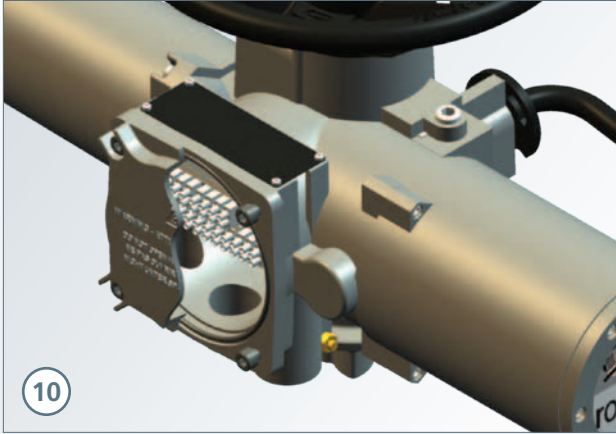

Features

- 1 3-phase, low inertia squirrel cage induction motor.
- 2 Oil bath lubricated gearcase, single stage worm and wheel drive.
- 3 Separable base incorporating valve drive component (AWT 10A – 35A only).
- 4 Handwheel, drive independent of motor gearing.
- 5 Hand-auto lever, depress for hand drive via a sliding clutch, auto return to motor drive.
- 6 Limit switch mechanism with local valve position indication.
- 7 Syncropak – includes motor reversing starter.
- 8 Double sealed terminal compartment.
- 9 Local control station - Local/Stop/Remote control selector, local Open/Local Close selector.
- 10 SyncroSET 10A – 35A Standard sealed terminal enclosure
- 11 SyncroSET + option Local Control Station (LCS)
- 12 Option Add-on-Pak (AOP)

Mechanical Specification and Certification

General

AWT range of actuators are designed for the electrical operation of valves, penstocks and dampers located in non-hazardous locations.

Comprising 3-phase motor, reduction gearbox, valve attachment with detachable drive component, limit and torque switches and terminal compartment. The SyncroPAK version includes the motor starter assembly.

Enclosure

Watertight WT IP68 – 7m for 72 Hrs to IEC60529, NEMA 4, 4X & 6, CSA WT. All covers incorporate “spigot” sleeved joints with O-ring seals.

Valve interface

AWT is available with mounting base and output drive couplings conforming to international standard ISO 5210 or USA standard MSS SP-102. Applications for which the various types of couplings have been designed are outlined and the appropriate data concerning stem acceptance diameters are given in the tables on page 10 & 11.

Handwheels

Handwheels are provided to allow manual operation of the valve during electrical power interruption.

10A - 40A Direct acting top mounted handwheel with optional side mounted geared drive, refer to page 10.

70A - 95A Side mounted geared drive handwheel with optional alternative gear ratios, refer to page 10.

During electric operation of the actuator the handwheel is mechanically disengaged from the drive. To engage, the hand/ auto selection lever is depressed and released after which handwheel operation remains selected. When electrical operation takes place, the actuator automatically returns to motor drive without lever or handwheel kickback. The hand/auto selection lever can be locked in the hand or auto positions using a 6 mm diameter hasp padlock (not supplied), preventing engagement of motor drive (locked in hand) or engagement of handwheel drive (locked in auto). Emergency disengagement of motor drive can be selected by depressing and holding the lever during electric operation.

Lubrication

AWT actuators are factory filled for life with premium quality gear oil, specified as SAE80/90 EP grade, available world-wide. Oil lubrication out-performs grease over the AWT standard temperature range -30 to +70 °C, with none of the problems associated with grease such as separation and tunneling.

Lubrication option - Food grade lubricant

AWT actuators may be supplied with the gearcase filled with Hydra Lube GB Heavy food grade lubricant. This lubricant is a synthetic non-aromatic hydrocarbon mixture with PTFE and other additives. It does not contain chlorinated solvents. Grease used in assembly and thrust bearings is Hydra Lube WIG Medium-NLGI-123.

Design Life

For isolating duty, torque ratings of actuators are based on a minimum maintenance free life of 10,000 open / close / open cycles with rated seating torque at stroke end and an average of 1/3 rated seating torque during stroke.

Frequency of operation – rating

AWT actuators are suitable for valve duty up to 60 starts per hour at a rate not exceeding 600 starts per hour. Rated S2/S3 25% to IEC 60034-1.

Operating temperature

Actuators are suitable for operation for ambient temperatures in the range -30 to +70 °C. For temperatures outside this range please apply to Rotork.

Vibration

Standard AWT Range actuators are suitable for applications where vibration severity does not exceed the following:

Plant induced: Where the cumulative level of all vibration within the frequency range of 10 to 1000 Hz is less than 1g rms. Shock: 5g peak acceleration.

Seismic: Frequency range 1 to 50 Hz, 2g acceleration if it is to operate during and after the event. 5g if it is only required to maintain structural integrity.

Finish

Actuators up to size 35A are finished in polyester powder coating, colour grey. Actuators size 40A and above are finished in air-dried polyurethane reinforced synthetic alkyd resin colour, grey. Finish options - Colour: Other colours may be specified, please apply to Rotork. Offshore: 2-pack epoxy coatings are available for extreme environmental conditions, please apply to Rotork.

Electromagnetic compatibility directive (EMC)

Actuators conform to the requirements of the European Economic Community EMC Directive 89/336/EEC as amended by 92/31/EEC by the application of EN 50081-2:1993 and EN 50082-2:1995.

Low voltage directive (LV)

Actuators conform to the requirements of the European Economic Community Low Voltage Directive 73/23/EEC amended by 93/68/EEC by the application of EN 60204-1 1998.

Machinery directive

Actuators follow the provision of the Machinery Directive (98/37/EEC). The AWT must not be put into service until the equipment into which it is being incorporated has been declared to be in conformity with the provisions of the European Community Machinery Directive (98/37/EEC).

Noise

Independent tests have shown that at 1m generated noise did not exceed 61 db(A).

Electrical Specification and Certification

Power supply

AWT actuators are suitable for operation with the following 3-phase, three wire nominal power supplies:

50 Hz

220, 240, 380, 400, 460, 500, 525 and 550 Volts.

60 Hz

208, 220, 230, 240, 380, 440, 460, 480, 575 and 600 Volts.

The required operating voltage must be specified at the time of order.

Actuator performance is guaranteed with a voltage tolerance +/-10% and a frequency tolerance +/-5 Hz. Actuators are capable of starting and running up to speed with a maximum 15% Volt drop. For power supply tolerance or Volt drop in excess of those stated above, please apply.

Uninterruptible power supplies UPS

AWT actuators are suitable for use with UPS Power supplies provided the tolerances specified above are not exceeded. UPS output should adhere to recognised supply standards such as EN50160.

Motor

The integral 3-phase squirrel cage induction motor is specially designed for valve actuation. Class F insulated with winding thermostat, the low inertia, high starting and stalling torque motor provides substantial reserves of power to assure torque switch operation at maximum setting with a voltage reduction as much as 10% below nominal.

Due to the unique low inertia design and lost motion or "hammerblow" drive, starting is instantaneous within 3 cycles of the mains frequency.

Motors are 15 minutes rated with a cyclic duration factor of 25% at 33% of actuator output rated torque giving a temperature rise not exceeding that permitted for class B insulation at standard nominal voltage.

Actuators are rated S2/S3 to IEC60034-1, 60 starts per hour at a rate not exceeding 600 starts per hour. Where long running times or regulation in excess of that stated above are required, alternative motor insulation class and rating are available. Please apply.

Refer to publication PUB005-006 for motor electrical data.

Motor thermostat

The motor thermostat enables the control circuit to be tripped and motor disconnected if the maximum permitted winding temperature is reached. This protection is independent of ambient temperature variation and motor current and provides optimum usage of motor thermal capacity. The thermostat will auto reset on motor cooling.

For SyncroSET actuators it is vital that the motor thermostat is connected in series with the motor reversing contactor coils.

Refer to publication PUB005-002.

Torque Limit switch mechanism

The unique combined torque and travel limit switch mechanism allows the actuator to be fitted to any valve type. Actuator wiring diagrams do not vary with the valve.

Simple mechanical selectors are set for torque or limit tripping to suit both seating (torque) or non seating (position limit) type valves. Selectors for both opening and closing torque switch protection are included to make site adjustment simple.

The valve turns range is set by lead screw adjustment that mimics actuator output turns. In addition two open and two close auxiliary switched are provided as standard for remote end of travel indication or interlocking. A mechanical 3 position pointer and dial provides local valve close, intermediate and open position indication.

Refer to publication PUB005-002 for full description.

Wiring and terminations

Jig built harnesses of individually stranded conductors, tropical grade PVC insulated, connect internal components to the applicable terminal compartment. All wires are identified with printed numbers.

Refer to SyncroSET and SyncroPAK specifications for details of user termination.

All actuators include the Installation and Maintenance Manual PUB005-003, wiring diagram and commissioning bag.

Option Add-on-Pak (AOP)

The Add-on-Pak is an optional extra and provides a range of indication options in addition to the standard switch mechanism:

- Continuous local valve position indication
- 2 or 6 additional, independent, auxiliary switches for valve indication or interlocking
- Remote analogue valve position indication – voltage or current

Gear driven from the switch mechanism, the AOP can be factory fitted or retrofitted in the field if plant indication requirements change. The AOP can be fitted to any AWT SyncroPAK or SyncroSET actuator.

Refer to publication PUB005-002 for full description.

Option Folomatic

This control option enables a Syncropak actuator to position a valve in proportion to analogue signal. It is suited to control applications with relatively slow rates of change and where high accuracy, high modulation are not a requirement such as level controls in water and sewage systems.

See publication PUB005-002.

AWT Mechanical summary

Mechanical data

Actuator size		10A 12A 18A	19A 20A 25A	35A	40A	70A	90A	91A	95A
Flange size	ISO 5210	F10	F14	F16	F25	F25	F30*	F25	F30
	MSS SP 102	FA10	FA14	FA16	FA25	FA25	FA30*	FA25	FA30
Thrust Base & Drive Couplings									
Thrust rating	kN	44	100	150	220	220	334	N/A	445
	lbs	10,000	22,480	33,750	50,000	50,000	75,000	N/A	100,000
Stem acceptance diameter Type 'A' (maximum)									
Rising	mm	32	38	54	64	70	70	N/A	N/A
	ins	1 ¹ / ₄	1 ¹ / ₂	2 ¹ / ₈	2 ¹ / ₂	2 ³ / ₄	2 ³ / ₄	N/A	N/A
Non-rising	mm	26	32	45	51	57	57	N/A	N/A
	ins	1	1 ¹ / ₄	1 ¹ / ₄	2	2 ¹ / ₄	2 ¹ / ₄	N/A	N/A
Type 'Z' - 'Z3'									
Z Rising	mm	32	51	67	73	83	83	N/A	83
	ins	1 ¹ / ₄	2	2 ⁵ / ₈	2 ⁷ / ₈	3 ¹ / ₄	3 ¹ / ₄	N/A	3 ¹ / ₄
Z3 Rising	mm	32	51	67	N/A	N/A	N/A	N/A	N/A
	ins	1 ¹ / ₄	2	2 ⁵ / ₈	N/A	N/A	N/A	N/A	N/A
Non-Rising	mm	26	38	51	57	73	73	N/A	73
	ins	1	1 ¹ / ₂	2	2 ¹ / ₄	2 ⁷ / ₈	2 ⁷ / ₈	N/A	2 ⁷ / ₈
Group 'B' couplings (non-thrust) Bore diameter									
Type 'B1' (fixed bore)	mm	42	60	80	100	100	120	N/A	N/A
Type 'B3' (fixed bore)	mm	20	30	40	50	50	50	50	N/A
Type 'B4' (maximum)	mm	20	30	44	50	60	60	60	N/A
	ins	³ / ₄	1 ¹ / ₄	1 ³ / ₄	2	2 ¹ / ₄	2 ¹ / ₄	2 ¹ / ₄	N/A
Handwheel ratio	Standard	1:1	1:1	1:1	1:1	15:1	15:1	15:1	15:1
	Optional	12:1	13.5:1	22.5:1	10:1/20:1	30:1	45:1	30:1	45:1

* 90A with B3 and B4 have flange size F25/FA25

AWT Performance summary

Performance Data

		Actuator output speeds							
rpm at 50 Hz		18	24	36	48	72	96	144	192
rpm at 60 Hz		21	29	43	57	86	115	173	230
Actuator size	Torque**	Nm	lbf·ft	Rating is max. torque switch setting in both directions			Not suitable for direct mounting on gate valves		
10A		34	34	34	34	34	34		
		25	25	25	25	25	25		
12A		81	81	81	68	48	41		
		60	60	60	50	35	30		
18A		108	108						
		80	80						
19A		135	135	135	135	135			
		100	100	100	100	100			
20A		203	203	203	203	176	142	102	
		150	150	150	150	130	105	75	
25A		400	400	298	244	244	230	149	
		295	295	220	180	180	170	110	
35A		610	610	542	474	474	366	257	
		450	450	400	350	350	270	190	
40A		1,020	1,020	845	680	680	542	406	
		750	750	625	500	500	400	300	
70A		1,490	1,490	1,290	1,020	1,020	745	645	542
		1,100	1,100	950	750	750	550	475	400
90A		2,030	2,030	1,700	1,355	1,355	1,020	865	730
		1,500	1,500	1,250	1,000	1,000	750	640	540
91A								1,355	1,355
								1,000	1,000
95A			3,000						
			2,200						

Note: Stall torque will be 1.4 to 2 times rated value depending on speed and voltage.

rotork®

Redefining Flow Control

www.rotork.com

A full listing of our worldwide sales and service network is available on our website.

Rotork plc
Brassmill Lane, Bath, UK
tel +44 (0)1225 733200
fax +44 (0)1225 333467
email mail@rotork.com

Scan with your smart phone
for more information on
this product range



PUB005-001-00
Issue 10/12

Formerly E310E. As part of a process of on-going product development, Rotork reserves the right to amend and change specifications without prior notice. Published data may be subject to change. For the very latest version release, visit our website at www.rotork.com
The name Rotork is a registered trademark. Rotork recognizes all registered trademarks.
Published and produced in the UK by Rotork Controls Limited. POWTG1012