

ACTUATOR: M07SD

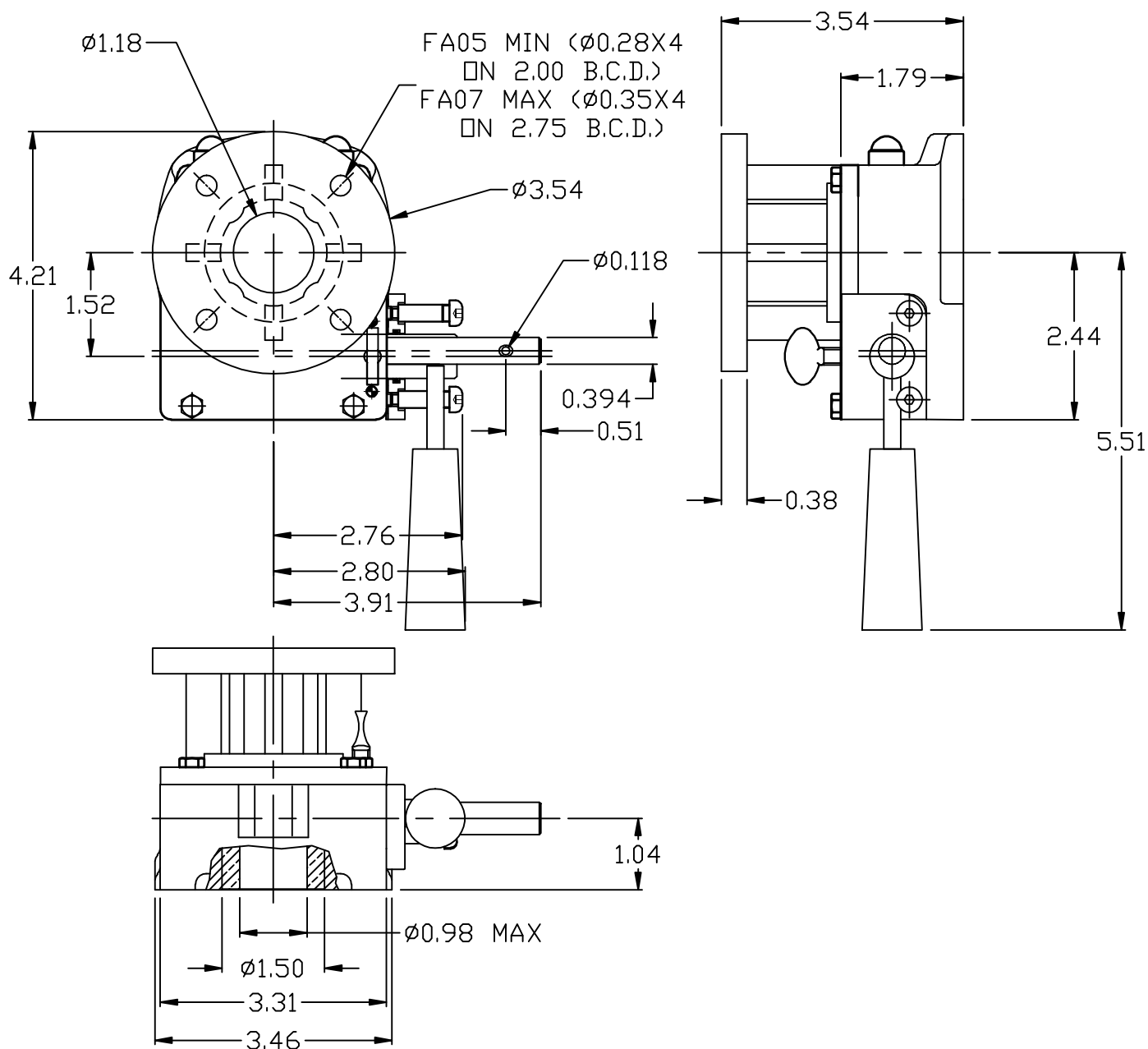

GENERAL INFORMATION

TRAVEL..... $90^\circ \pm 5^\circ$ AT BOTH ENDS

RATIO.....51:1

TURNS TO CLOSE..12.75

MECHANICAL ADVANTAGE..... $9.0 \pm 10\%$

OUTPUT TORQUE(1000 CYCLES)..3000 IN-LBS

INPUT TORQUE(1000 CYCLES)....333 IN-LBS

MOUNTING HOLE DETAIL: PREFERRED....FA07 (4 \times 5/16-18 ON 2.75 BCD)

(MSS SP-101)

MAXIMUM.....FA07 (4 \times 5/16-18 ON 2.75 BCD)

MINIMUM.....FA05 (4 \times 1/4-20 ON 2.00 BCD)



MASTERGEAR

A REGAL-BELOIT COMPANY
5466 EAST ROCKTON RD. • SOUTH BELOIT, IL 61080

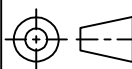

DIMENSIONS
IN
INCHES

SCALE

1:3

DRAWING
No.

M07SD

THIS PRINT IS CONFIDENTIAL AND IS THE PROPERTY OF MASTERGEAR. THIS PRINT SHALL NOT BE USED, COPIED OR REPRODUCED IN WHOLE OR IN PART NOR SHALL THE CONTENTS BE REVEALED IN ANY MANNER TO ANYONE UNLESS WRITTEN PERMISSION IS OBTAINED FROM MASTERGEAR. ©

NJC

REV.
1/13/06