

INPUT FLANGE DETAILS					
	FLANGE O/DIA. & THICKNESS	SHAFT DIA.	RECESS DIA.	HOLE DETAILS (45° OFF CENTRES)	KEY DETAILS
ISO F14	Ø175 (Ø6.89") x 15 (0.59")	Ø30.00 -0.05 (Ø1.181" -0.002")	Ø100.05 +0.05 (Ø3.939" +0.002")	4 HOLES Ø16.5 (Ø0.65") ON Ø140.0 (Ø5.51") P.C.	8x7x55 (0.31"x0.28"x2.17")
FA14	Ø175 (Ø6.89") x 15 (0.59")	Ø30.00 -0.05 (Ø1.181" -0.002")	Ø95.27 +0.05 (Ø3.751" +0.002")	4 HOLES Ø16.5 (Ø0.65") ON Ø140.0 (Ø5.51") P.C.	8x7x55 (0.31"x0.28"x2.17")
ISO F16	Ø210 (Ø8.27") x 20 (0.79")	Ø40.00 -0.05 (Ø1.575" -0.002")	Ø130.05 +0.05 (Ø5.120" +0.002")	4 HOLES Ø20.5 (Ø0.81") ON Ø165.0 (Ø6.50") P.C.	12x8x55 (0.47"x0.31"x2.17")
FA16	Ø210 (Ø8.27") x 20 (0.79")	Ø40.00 -0.05 (Ø1.575" -0.002")	Ø126.92 +0.05 (Ø4.997" +0.002")	4 HOLES Ø20.5 (Ø0.81") ON Ø165.0 (Ø6.50") P.C.	12x8x55 (0.47"x0.31"x2.17")

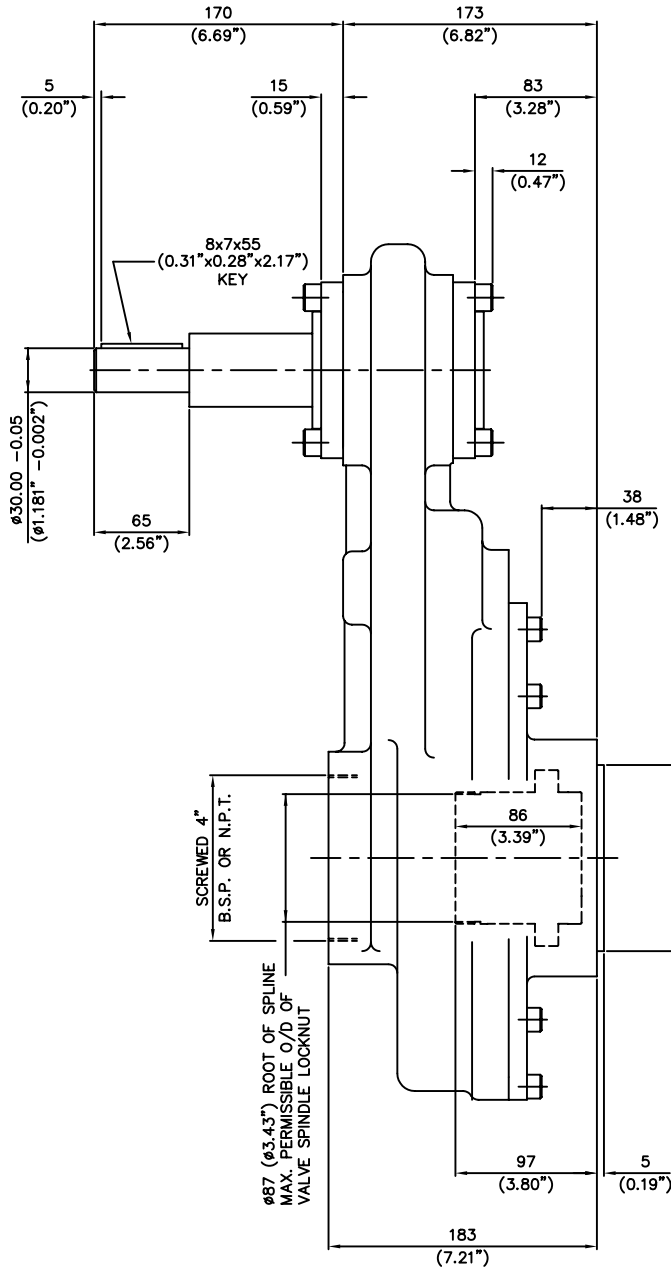

4 OFF M12 SCREWS (EACH SIDE)  
ON Ø140 (Ø5.51") P.C.

8 OFF M10 BASEPLATE SECURING  
SCREWS EQUALLY SPACED ON  
CENTRES ON Ø312 (Ø12.28") P.C.

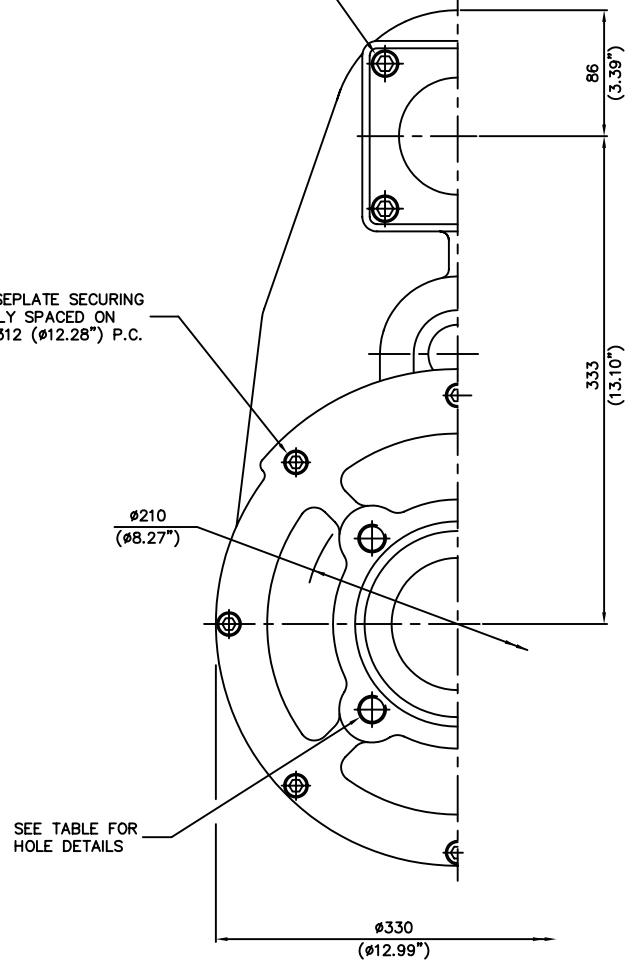

BASEPLATE DETAILS		
	SPIGOT DIA.	HOLE DETAILS (45° OFF CENTRES)
ISO F16	Ø129.95 -0.05 (Ø5.116" -0.002")	4 HOLES M20x25 (0.98") DEEP ON Ø165.0 (Ø6.50") P.C.
FA16	Ø126.87 -0.25 (Ø4.995" -0.010")	4 HOLES 3/4"UNCx25 (0.98") DEEP ON Ø165.0 (Ø6.50") P.C.

1	CN914 JMO 17.6.97
A	ORIGINAL ISSUE
ISSUE	ALTERATIONS

**rotork  
gears**

NOMINAL RATIO	4:1	6:1	8:1	10:1	12:1	15:1
EXACT RATIO	4.01:1	6.10:1	7.95:1	10.20:1	12.26:1	15.03:1
FACTOR (MECH. ADVANTAGE)	3.600	5.490	7.156	9.180	11.030	13.520

DRAWN: -	S.W.	10.9.96	SCALE
CHECKED: -			1:1.4

EXECCO LTD © 1996

OUTLINE DETAILS OF IS8  
ISO & USA STANDARD

PUB\IS8CD