

- NOTES:
1. MAX. ALLOWABLE OPERATING PRESSURE ( MAOP ) = 10 BAR ( 150 PSIG )
  2. WARNING - SEE ROTORK INSTALLATION, OPERATION & MAINTENANCE MANUAL BEFORE MOUNTING, INSTALLING OR SERVICING.
  3. SPECIFY SUPPLY AIR PRESSURE FOR SPRING-RETURN ACTUATOR.
  4. ACTUATOR SHOWN IN FULL CW POSITION, FLAT ON SHAFT SHOWS VANE LOCATION POSITION ( SPRING END / AIR START ).
  5. SPECIFY SPRING DIRECTION , CW STANDARD.
  6. WEIGHT 6.01 KG ( 13.25 LB. )

	IMPERIAL	METRIC
THREAD SIZE "A"	5/16-18 UNC	M8 x 1.25
THREAD SIZE "B"	5/16-18 UNC	M8 x 1.25
AIR PORT SIZE	1/4-18 NPT	G1/4

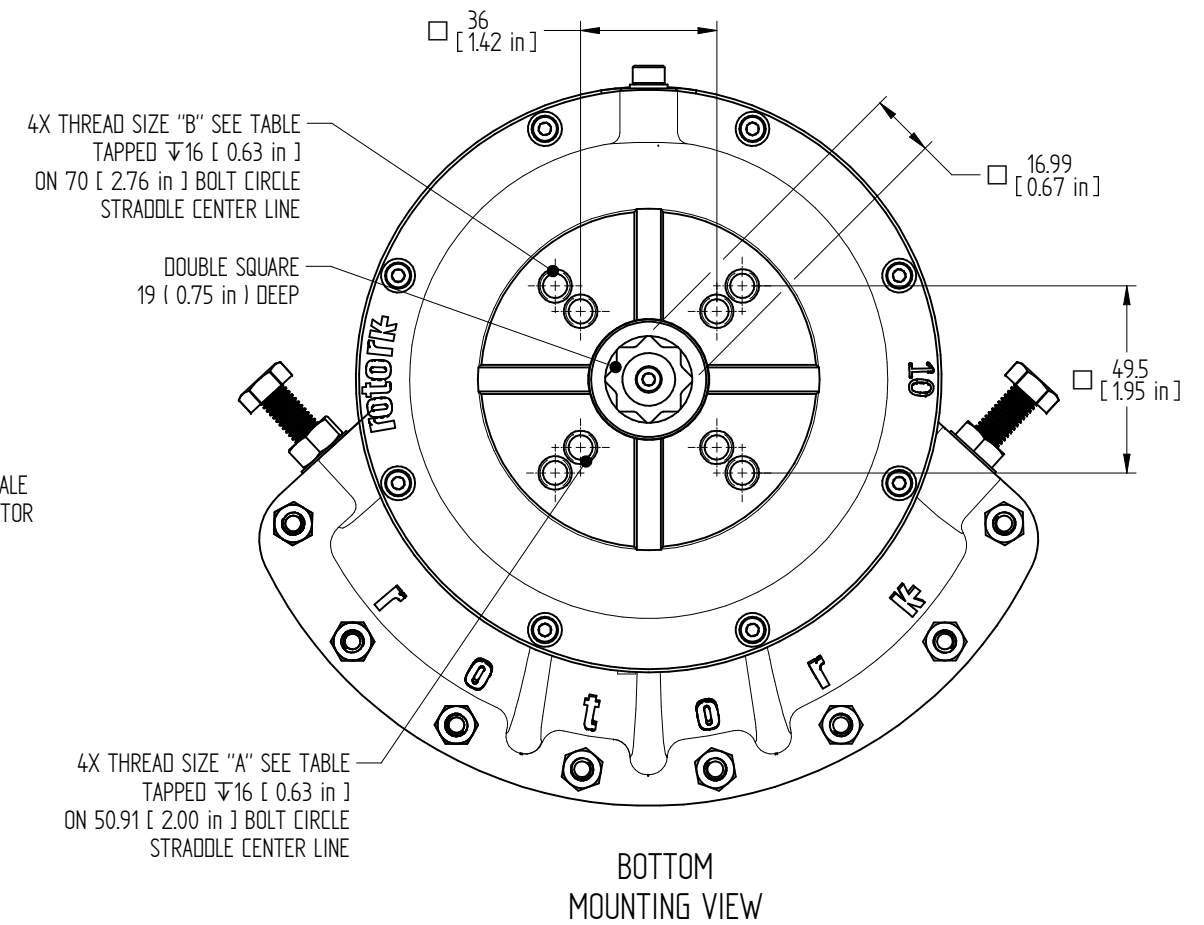
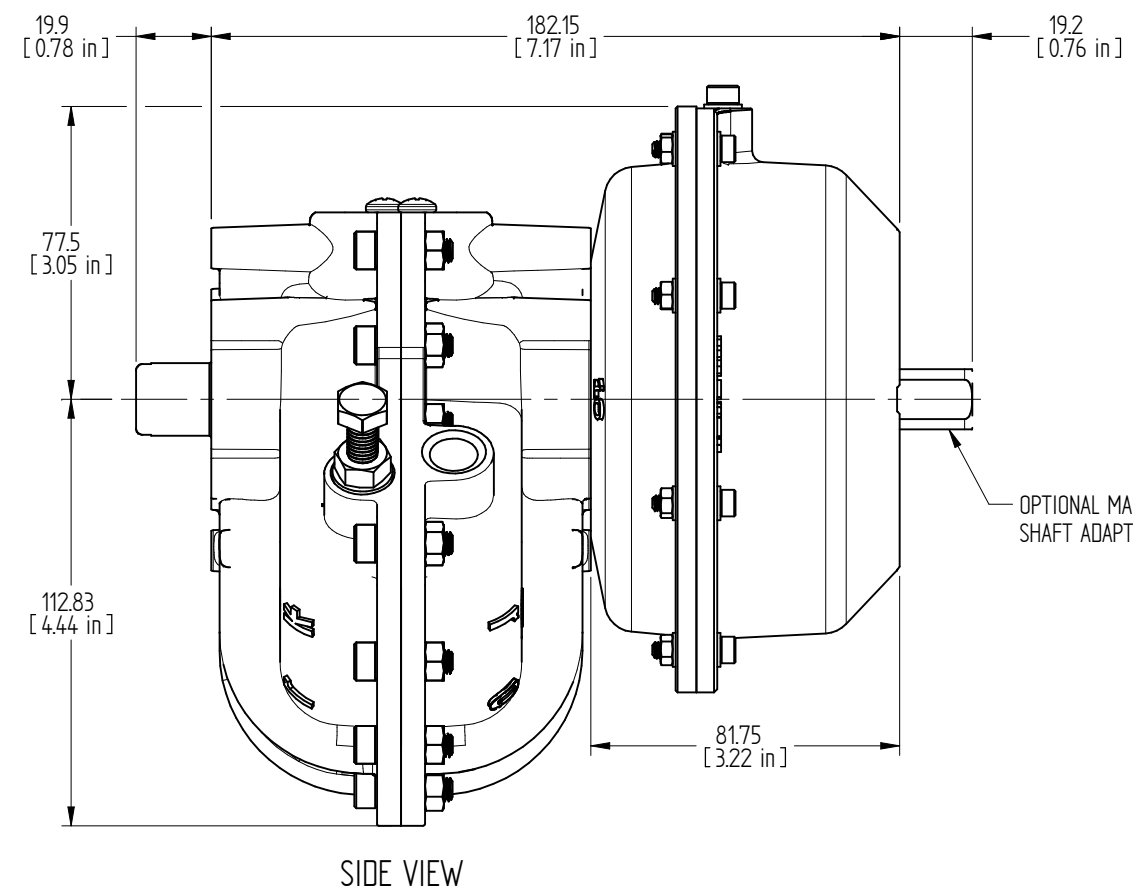
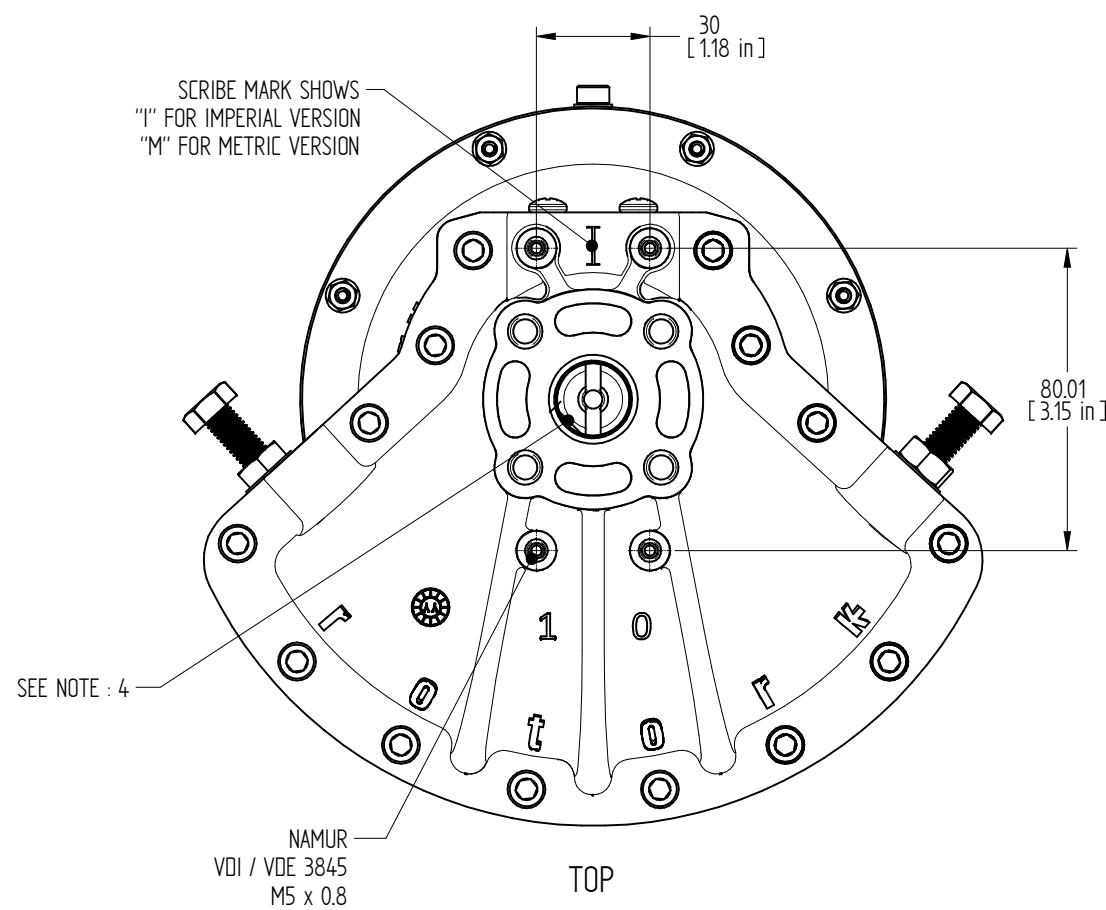
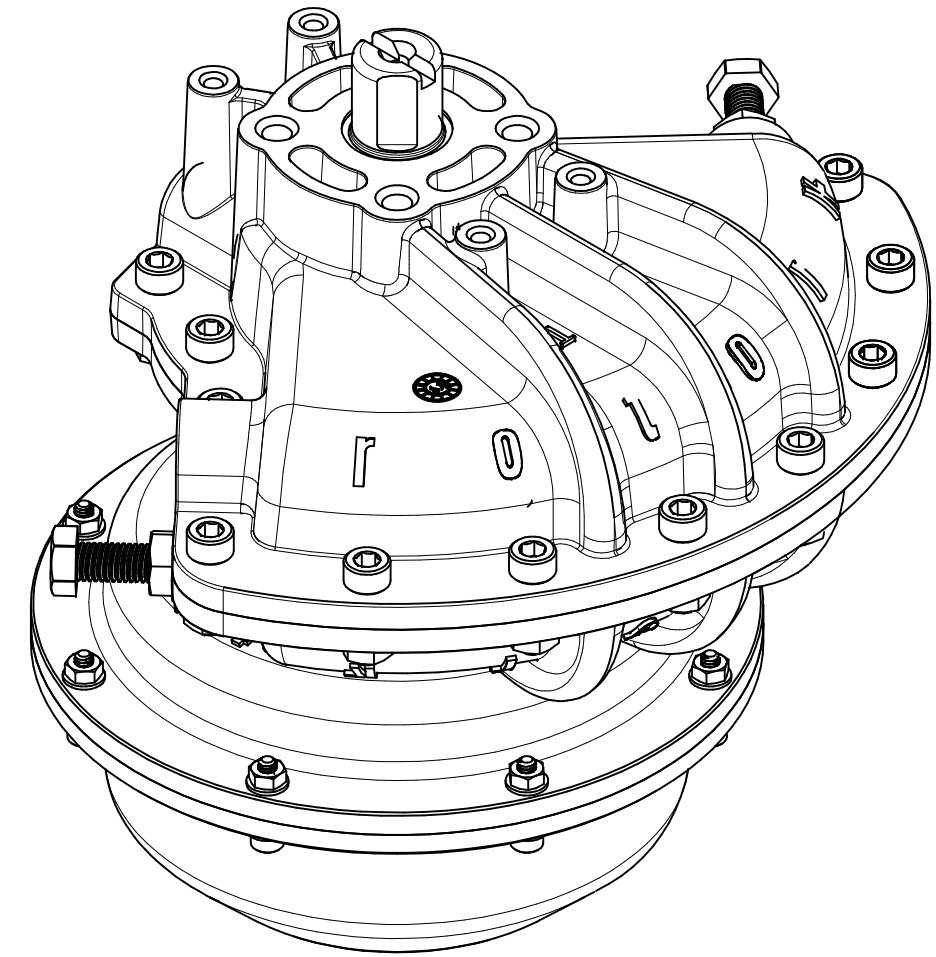
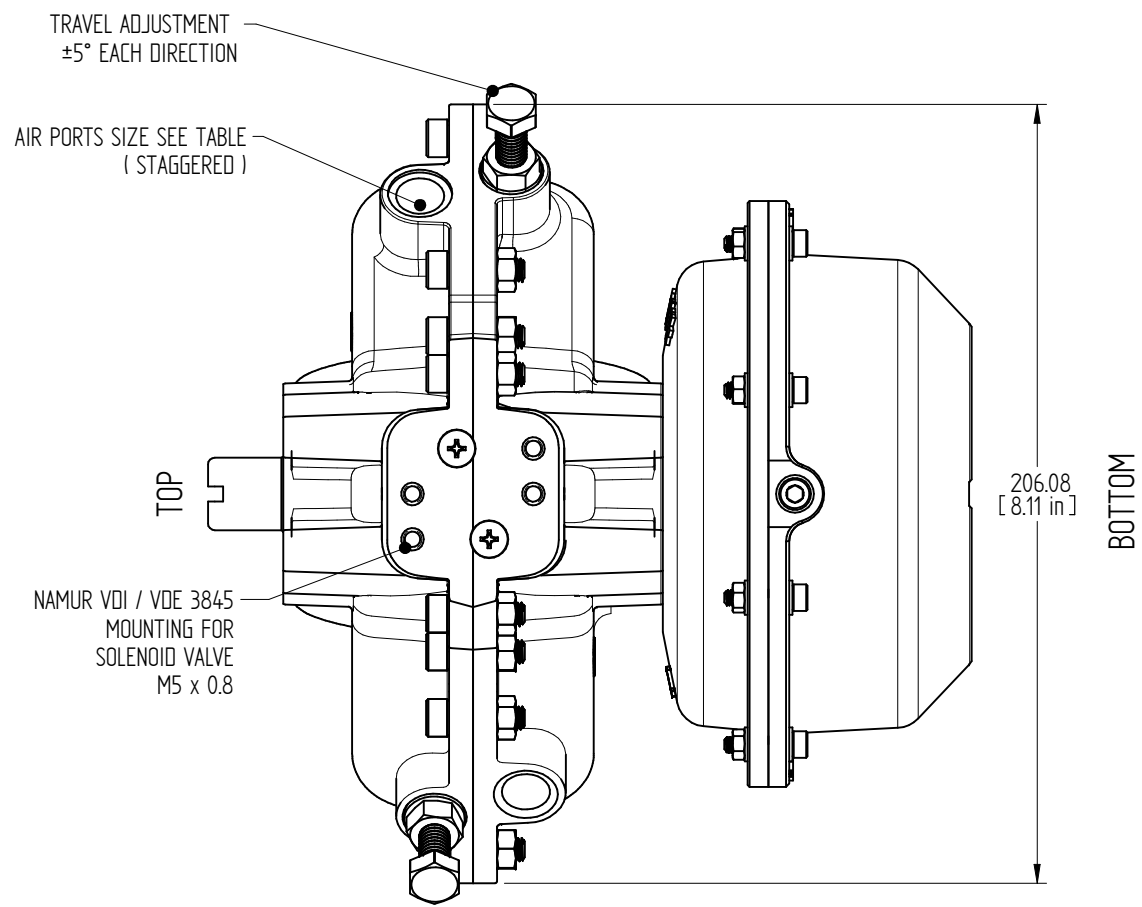
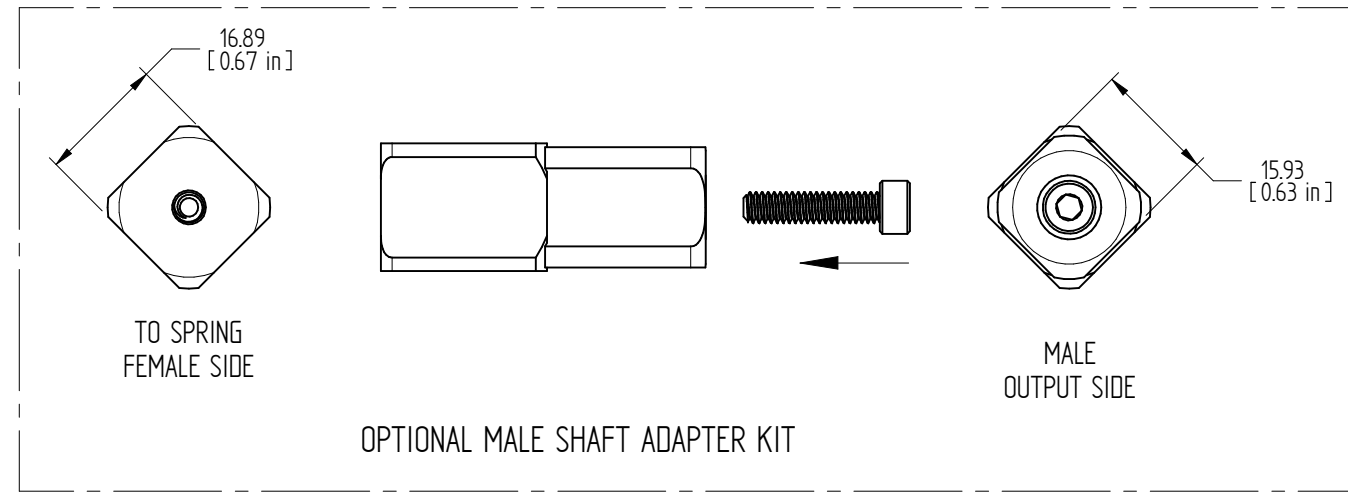

Rev	ECN	Revised	Approved	Date	Change Description
D		K.SEKAR	K.PRICE	04-AUG-2016	DIM. 206.08 WAS 216.89 (C8)
C		K.SATHEESH	K.PRICE	19-FEB-2016	EXPLODED VIEW ADDED IN SHEET2
B		K.SEKAR	K.PRICE	14-JUL-2015	DESCRIPTION UPDATED
A		K.SEKAR	K.PRICE	12-JUN-2015	REDRAWN: SOLID EDGE 3D

**rotork**® This drawing is confidential and is the property of Rotork Dallas Inc. and must not be reproduced either wholly or partly. All rights in respect of patents, designs and copyrights are reserved. © 2015

Dallas, Texas - USA  
www.rotork.com

Document type		GENERAL ARRANGEMENT		Title	
Created		K.SEKAR		KT-10-SR	
Checked		S.SUDHIR		IMPERIAL / METRIC AIR PORTS & MOUNTING HOLES	
Approved		K.PRICE		Drawing Number	
		12-JUN-2015		D000000210	
		12-JUN-2015		Sheet 1 of 2	
		12-JUN-2015		Size A2	

Rev C

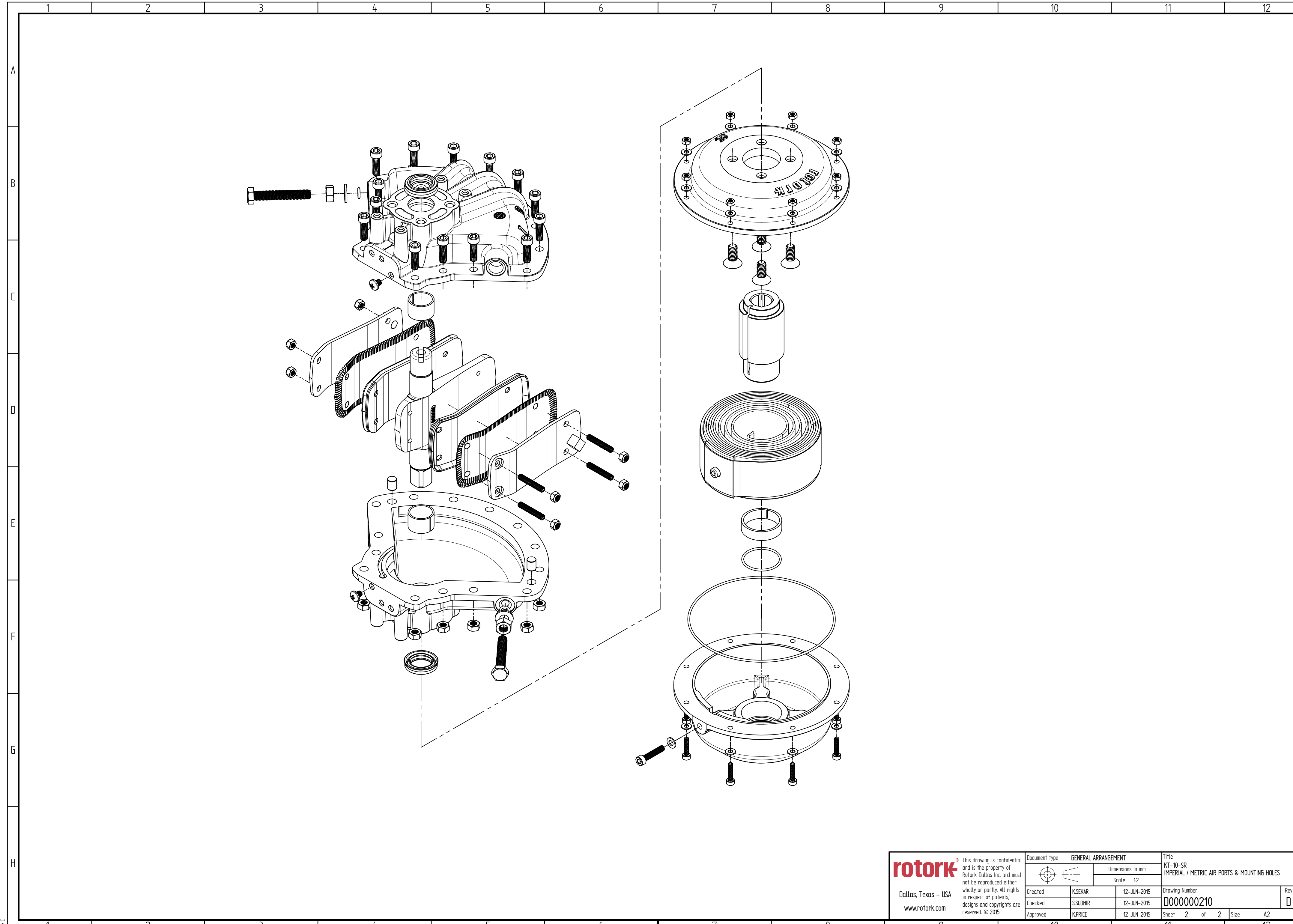

<p>Dallas, Texas - USA www.rotork.com</p>	This drawing is confidential and is the property of Rotork Dallas Inc. and must not be reproduced either wholly or partly. All rights in respect of patents, designs and copyrights are reserved. © 2015			Document type <b>GENERAL ARRANGEMENT</b>	Title <b>KT-10-SR IMPERIAL / METRIC AIR PORTS &amp; MOUNTING HOLES</b>
	Dimensions in mm Scale 1:2		Drawing Number <b>D000000210</b>		Rev <b>D</b>
	Created K.SEKAR	12-JUN-2015	Drawing Number <b>D000000210</b>	Sheet 2 of 2 Size A2	
	Checked S.SUDHIR	12-JUN-2015	Approved K.PRICE	12-JUN-2015	Sheet 2 of 2 Size A2

Rev C