

IQT1000 & 2000 ACTUATORS WITH FAILSAFE OPTION

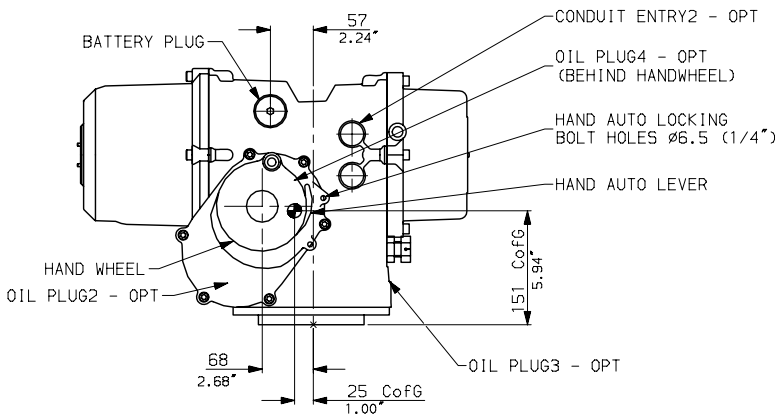
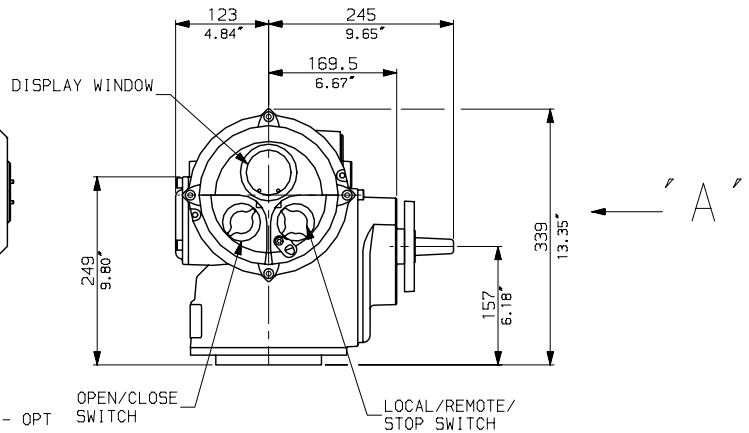
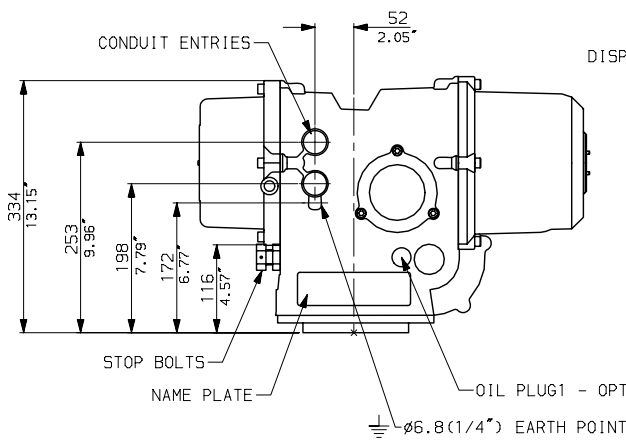
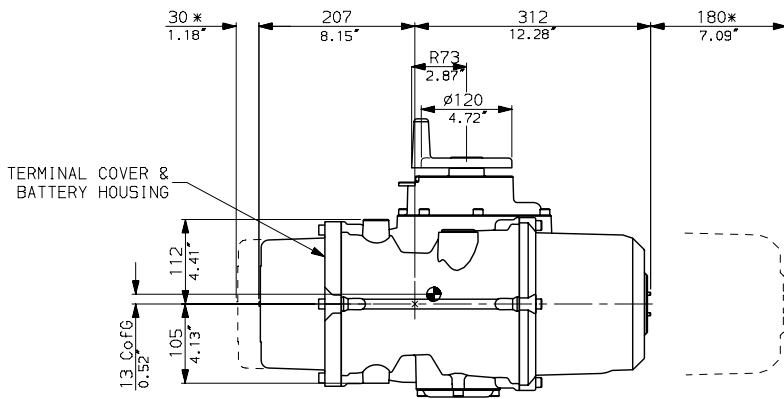

VIEW ON ARROW 'A'

NOTES:

:REGISTERED DESIGN 000034863

:F12/FA12 /F14/FA14 BASE OPTION

IS DETAILED TO SUIT THE RELEVANT COUPLING ARRANGEMENTS.

CONDUIT ENTRIES



TAPPED 2xM25x1.5p
(OPTIONAL ADAPTORS FOR
M20, 1/2", 3/4", 1"NPT, 1 1/4", 1 1/2",
PG16 & PG21).

rotork

IQT1000, 2000 FS DATA

Date 180905

Scale 1:10

IQT1000, 2000 BASES

F12 / FA12 BASES

F12 BASE DETAILS

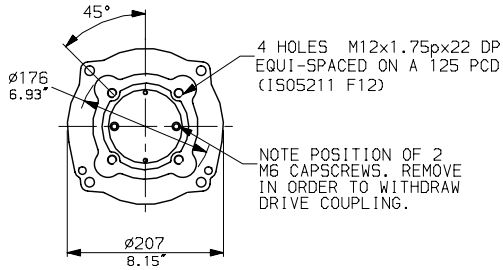

FA12 BASE DETAILS

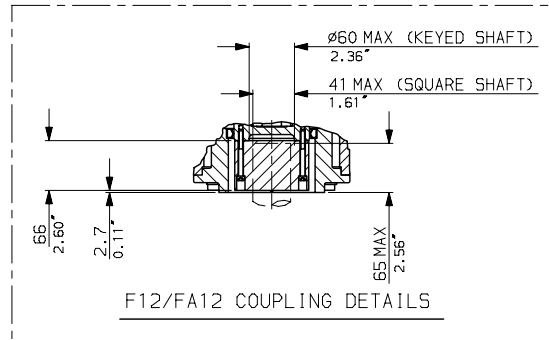
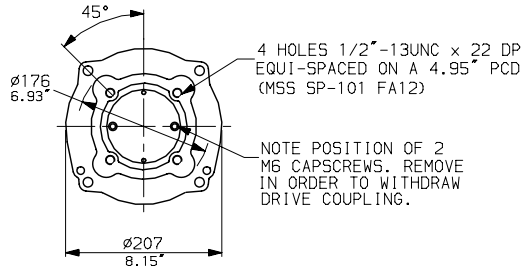

F14 / FA14 BASES

F14 BASE DETAILS

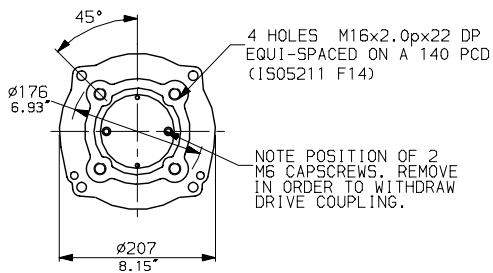

FA14 BASE DETAILS

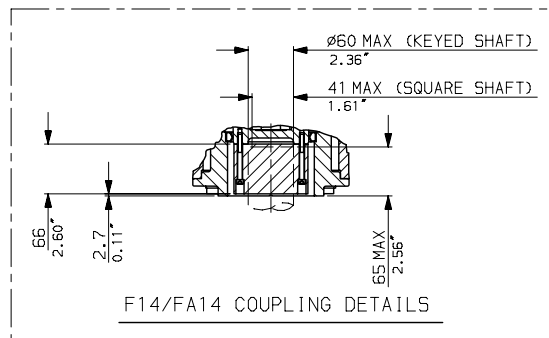
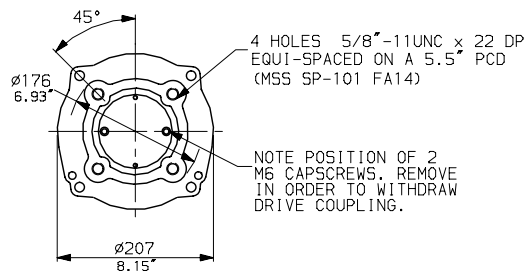

rotork

IQT1000, 2000 BASES

Date 210605 Scale 1:10