

**INSTALLATION AND OPERATING INSTRUCTIONS  
FOR  
SM/LA-E3330 AND SM/LA-R3300 SERIES FAIL SAFE ACTUATORS**

I. <u>Theory of Operation</u> .....	-2-
A. <u>Mechanics</u> .....	-2-
II. <u>Installation</u> .....	-2-
A. <u>Storage</u> .....	-2-
B. <u>Wiring &amp; Fusing</u> .....	-2-
C. <u>Customer Valve Mounting Procedure</u> .....	-3-
III. <u>Subassembly Alignments</u> .....	-3-
A. <u>Tandem Pot Alignment</u> .....	-3-
B. <u>4 -20 mA Transmitter Calibration</u> .....	-3-
C. <u>Holding Brake Adjustment</u> .....	-3-
IV. <u>Repair &amp; Replacement Procedures</u> .....	-4-
A. <u>Return Spring or Ballscrew/Ballnut Repair</u> .....	-4-
B. <u>Lubrication</u> .....	-4-
C. <u>Holding Brake Removal</u> .....	-4-
D. <u>Replacing Feedback Assembly</u> .....	-4-
E. <u>Replacing the Feedback Potentiometer</u> .....	-4-
F. <u>Replacing Limit Switches</u> .....	-5-
G. <u>Motor Replacement</u> .....	-5-
H. <u>Repairs to Gearbox</u> .....	-5-
V. <u>Suggested Spare Parts</u> .....	-5-
VI. <u>Troubleshooting</u> .....	-6-
LA-3330 Major Dimensions.....	-7-
SM-3330 Major Dimensions.....	-8-
Assembly Drawing.....	-9-
SM/LA-3330 Typical Wiring Diagram.....	-10-

*Due to wide variations in the terminal numbering of actuator products, actual wiring of this device should follow the print supplied with the unit.*

## I. Theory of Operation

### A. Mechanics

A single, phase, reversible, three wire, permanent split capacitor motor supported by roller bearings produces torque at the motor pinion gear. An "electrically-on" holding brake is located on the opposite end of the motor shaft.

The motor torque is increased (with a corresponding decrease in speed) through two stages of bearing supported spur gearing. The last power gear transmits torque through a one-way roller clutch to a ballscrew. The ballscrew is supported by an angular contact roller bearing and a radial roller bearing and features a fine pitch gear (for position feedback) on one end and a hardened rolled thread on the other end. Riding along this rolled thread is a ballnut which allows the high torque/low speed rotary output of the ballscrew to be converted to linear motion. The ballnut transmits this thrust thorough a "universal" joint (which absorbs any angular or axial misalignment) to either a bushing supported linear output shaft (LA units) or a bushing supported gear rack (SM units) while further compressing a return spring. On the "LA" units the load to be moved is coupled directly to this linear output shaft. On the "SM" units the innermost bushing is statically keyed to the housing and dynamically keyed to the gear rack to provide and maintain the proper rotational attitude of the gear rack during operation. The gear rack engages a pinion on the bearing supported rotary output shaft to convert the linear motion to 90 degree rotary output. On the "LA" units the ex-tension of the linear output shaft serves as a visual indication of the approximate valve position. On the "SM" units a dial indicator is provided.

The actuator produces an amount of force required to move the customer's valve, damper, variable speed drive, etc. and an equal amount of force to compress the return spring. In normal operation, the actuator can be run to intermediate positions and held by energizing the "electrically-on" holding brake located on the motor. The holding brake

draws only a small amount of power when energized and can energized continuously without degradation. Thus, positioning between the end of travel limit switches for extended periods of time is easily accomplished. Upon loss of electrical power, the holding brake is de-energized, and the spring returns the load to the home position (fully open or closed depending on the actuator model). The speed of spring return is related to load and can vary from 3 to 10 seconds for the full stroke length. As the actuator output shaft reaches the "home" position the internal energy of the motor and gearing is allowed to "overrun" the output shaft by means of the one-way roller clutch, and is thus safely dissipated without damage to the actuator or the customer's valve. A subtle feature of the one-way roller clutch is that it provides mechanical thrust or torque limiting in the (motor) driven direction. Thus if the actuator is driven into an obstruction while compressing the return spring the one way clutch will slip until the obstruction is removed, the actuator is reversed, or electrical power is interrupted.

With the actuator set so the customer's valve or damper is fully seated before reaching the actuators physical end of travel, the valve will be "positively" seated or "cushioned" seated (a positive seating force will be guaranteed).

## II. Installation

### A. Storage

If the actuator will not be installed immediately, it should be stored in a clean, dry area where the ambient temperature is not less than -20 F. The actuator should not be stored in a corrosive environment.

### B. Wiring & Fusing

All installation wiring shall meet the National Electrical Standards, as well as any state and or/local standards which may apply. Shielded wiring is recommended for feedback wiring. For rest of wiring, refer to pages 10, or 11.

## B. Wiring & Fusing cont.

Fusing is not provided in the 3300 series, and must be installed in line. Fuse to a current value slightly higher than the driven load (slow-blow fuse).

## C. Customer Valve Mounting Procedure

**NOTE:** The actuator has been preset to your stroke requirement at the factory.

1. Run the actuator until the end of travel switch nearest the spring return (or failed) position is tripped, and the holding brake is energized.
2. Mount valve to actuator. Valve should be fully open or closed at this position.
3. Run actuator to the other end of travel and back. Adjust end of travel limit switch cam if necessary.
4. Run actuator from the spring return position and de-energize (disconnect power to simulate power outage). Actuator should go to spring return position. Check for full seating of valve. If not fully seated adjust mounting of valve to actuator so the actuator output shaft is pushed slightly away from spring return position so full spring seating force is applied to valve.

## III. Subassembly Alignments

### A. Tandem Pot Alignment (Requires optional tandem potentiometer)

The feedback pot assembly should not need further calibration. If the tandem pot was disassembled, recalibration is necessary.

- 1) Adjust actuator to minimum position. Resistance reading for VR1 should be approximately 50 + or - 10% ohms across terminals 4 & 5. If not, loosen potentiometer mounting nut and move **ONLY THE POT BODY**. Tighten the mounting nut and make sure limit switches are still functional.

- 2) Check resistance reading of VR2 (top pot). If resistance is approximately 50 ohms, calibration is complete.
- 3) If VR2 is not near 50 ohms, loosen pot clamp's hex head screw and slowly rotate top pot until approximately 50 ohms is reached. Tighten pot clamp.

### B. 4 -20 mA Transmitter Calibration (Requires potentiometer & EC-10649 transmitter).

For the unit to function properly the 4 mA end of the feedback potentiometer must be preset to 50 ohms. This will insure linearity across the active region of the feedback potentiometer. Both the RANGE and ELEVATION adjustments interact. The ELEVATION sets the 4 ma point, and the RANGE sets the 20 mA point.

- 1) Position the actuator to the valve "closed" position.
- 2) Adjust ELEVATION for 4 ma.
- 3) Position the actuator to the valve "open" position.
- 4) Adjust RANGE to 20 ma.
- 5) Repeat all steps until no further adjustment is necessary, as RANGE and ELEVATION do interact.
- 6) To reverse the 4-to-20 mA output, interchange the blue and yellow transmitter wires and adjust ELEVATION with the valve "open" and RANGE with the valve "closed".

### C. Holding Brake Adjustment

- 1) Disconnect all power.
- 2) Loose two #6-32 setscrews holding brake armature assembly.
- 3) With .005/.010 inch air gap securely tighten the two setscrews.

## IV. Repair & Replacement Procedures

### A. Return Spring or Ballscrew/Ballnut Repair

***DANGER!!!*** Considerable spring force is constantly exerted by the pre-compressed return spring which attempts to separate the main housing castings. Plugs prevent access to the four 3/8" housing bolts. Do not attempt to remove plugs and loosen the bolts. Disassembly can only be done by Jordan Controls trained personnel. Personal injury can result from attempting to separate the main housing castings. **DO NOT DISASSEMBLE !**

### B. Lubrication

The gearbox, ballscrew/ballnut, and rack & pinion are permanently lubricated. Relubrication is only required if the unit is disassembled for repair, at which time all parts must be completely and thoroughly cleaned. If the gearbox or rack & pinion are disassembled, relubricate with AMOCO-RYKON PREMIUM GREASE No. 2.

### C. Holding Brake Removal

- 1) Disconnect all power.
- 2) Loosen two #6-32 setscrews on brake armature assembly.
- 3) Remove armature assembly.
- 4) Disconnect brake leads from brake circuit (EC-10678).
- 5) Remove four #4-40 cap screws from brake coil assembly.
- 6) Remove coil assembly.
- 7) Reverse steps to assemble (see Holding Brake Adjustment Procedure on Page 3).

### D. Replacing Feedback Assembly

- 1) Remove three screws which hold the feedback assembly to the feedback mounting plate.
- 2) Remove the feedback assembly from the feedback mounting plate by lifting straight out.
- 3) A gear will be positioned on the shaft

of the feedback assembly. It is held in place with two setscrews. Note the location of the gear on the shaft.

- 4) Loosen the setscrews, remove the gear, and transfer it to the new feedback assembly; positioning it to the same location as it was on the original feedback assembly.
- 5) Insert the assembly into the feedback mounting plate being sure the gear is properly meshed with its mating gear.
- 6) Install the three screws removed in Step 1.
- 7) Using a 25 watt solder iron, transfer the wires from the original feedback assembly to the new one; one at a time insure proper wiring.
- 8) Align the feedback following the alignment procedure.

### E. Replacing the Feedback Potentiometer

***NOTE:*** The potentiometer used with the feedback assembly is a 348 degree potentiometer with no mechanical stops. Incorrect mechanical orientation of the potentiometer shaft or setting of the limit switches can cause the potentiometer shaft to be driven into the "deadband" or "open" zone, causing erratic operation.

- 1) Remove three screws which hold the feedback assembly to the feedback mounting plate.
- 2) Remove the feedback assembly from the housing by lifting straight out. A gear will be positioned on the shaft of the feedback assembly.
- 3) Noting (or marking) potentiometer wiper position & feedback gear position, remove potentiometer body nut and feedback gear.
- 4) Loosen setscrews on each cam (noting color order), and lift potentiometer away from the frame.
- 5) Using a 25 watt solder iron, transfer the wires from the old potentiometer to the new one.

#### E. Replacing the Feedback Potentiometer

- 6) Reverse procedure on installing new potentiometer into frame.

#### F. Replacing Limit Switches

- 1) Limit switches are held in position with two screws. Remove the screws to replace a switch, and transfer the wires from the old screw to the new one: one at a time using a 25 watt solder iron.
- 2) Minor re-alignment of the switch settings may be required, refer to the alignment instructions.

#### G. Motor Replacement

- 1) Remove all power from the actuator.
- 2) Remove the motor mounting screws.
- 3) Remove the old motor from the housing, leave the wires connected, and install the new motor. Tighten the screw evenly to insure motor alignment with the first stage power gear. If the motor is not mounted straight, bearing binding will occur.
- 4) Using a 25 watt solder iron, transfer the two soldered wires one at a time, remove common motor lead from TB2 and install new motor lead into connector. Apply power and check for proper rotation & operation.

#### H. Repairs to Gearbox

The pictures on page 9 is only a general location picture and may or may not represent your actuator accurately.

- 1) With power disconnected, remove the feedback assembly plate from the gearbox housing.
- 2) Remove the three cap screws and pull off gearbox housing.
- 3) Replace any worn or broken parts.
- 4) Clean and insert all gears, replace any damaged or worn parts. Be sure all retaining rings are in grooves of shafts.

- 5) Insert the gears one at a time, starting with the first stage and checking for proper gear mesh.

- 6) After all gears are inserted into the housing and checked for proper mesh, coat the gears with AMOCO-RYKON PREMIUM GREASE No. 2 or equivalent. DO NOT pack the gear case- only a light coating is needed.

- 7) Carefully install gearbox housing and align it with the housing on the dowel pin. Do not force the cover on. With the cover in place, insert the three cap screws and feedback assembly plate. Install field wiring to terminal strip.

- 8) Apply power and check for proper operation.

#### V. Suggested Spare Parts

1. Motor
2. Potentiometer
3. Limit Switches
4. Limit Switch Actuator
5. Power Gears
6. Feedback Gears
7. Motor Capacitor
8. O-rings
9. Bearings
10. Rack & Pinion ("SM" units)
11. Output Bushing & Seal

## VI. Troubleshooting

PROBLEM	POSSIBLE CAUSE	SOLUTION
Valve won't position	<ol style="list-style-type: none"> <li>1) No power applied to electric actuator</li> <li>2) Actuator not aligned with valve stroke</li> <li>3) Electric actuator defective</li> <li>4) Valve operator assembly jammed or not aligned with electric actuator</li> <li>5) Valve jammed</li> <li>6) Actuator not properly sized for valve used</li> </ol>	<ol style="list-style-type: none"> <li>1) Apply power</li> <li>2) Do Alignment</li> <li>3) Repair electric actuator</li> <li>4) Align or repair</li> <li>5) Repair or replace valve</li> <li>6) Recalculate valve thrust required and change actuator to proper gear ratio</li> </ol>
Valve won't seat or drive full closed	<ol style="list-style-type: none"> <li>1) "Closed" position limit switches not set correctly</li> <li>2) Valve seat defective or dirt in valve</li> <li>3) Broken gearing in electric actuator</li> </ol>	<ol style="list-style-type: none"> <li>1) Adjust closed position limit switch</li> <li>2) Repair seat position</li> <li>3) Repair</li> </ol>
Electric motor runs but valve does not move	<ol style="list-style-type: none"> <li>1) Broken gear in electric actuator</li> <li>2) Ballnut/ballscrew damaged</li> </ol>	<ol style="list-style-type: none"> <li>1) Repair</li> <li>2) Replace</li> </ol>
Electric actuator will not run with power applied (no valve)	<ol style="list-style-type: none"> <li>1) Defective motor</li> <li>2) Defective motor capacitor</li> <li>3) Gears jammed or broken</li> <li>4) Limit switches open</li> <li>5) Power applied to both directions at same time electrically stalling motor</li> <li>6) Solenoids or lights connected in parallel with motor</li> <li>7) Brake not releasing</li> </ol>	<ol style="list-style-type: none"> <li>1) Replace</li> <li>2) Replace</li> <li>3) Repair</li> <li>4) Adjust or replace</li> <li>5) Correct wiring</li> <li>6) Remove (upset phase shift of motor)</li> <li>7) Check brake gap; check brake circuit</li> </ol>
No signal from feedback potentiometer(s)	<ol style="list-style-type: none"> <li>1) Feedback potentiometer not wired or incorrectly wired</li> <li>2) Feedback potentiometer broken</li> <li>3) Signal monitor device defective</li> </ol>	<ol style="list-style-type: none"> <li>1) Rewire</li> <li>2) Replace</li> <li>3) Repair or replace</li> </ol>

# LA-3330 Major Dimensions

DIMENSIONS = INCHES  
( MM )

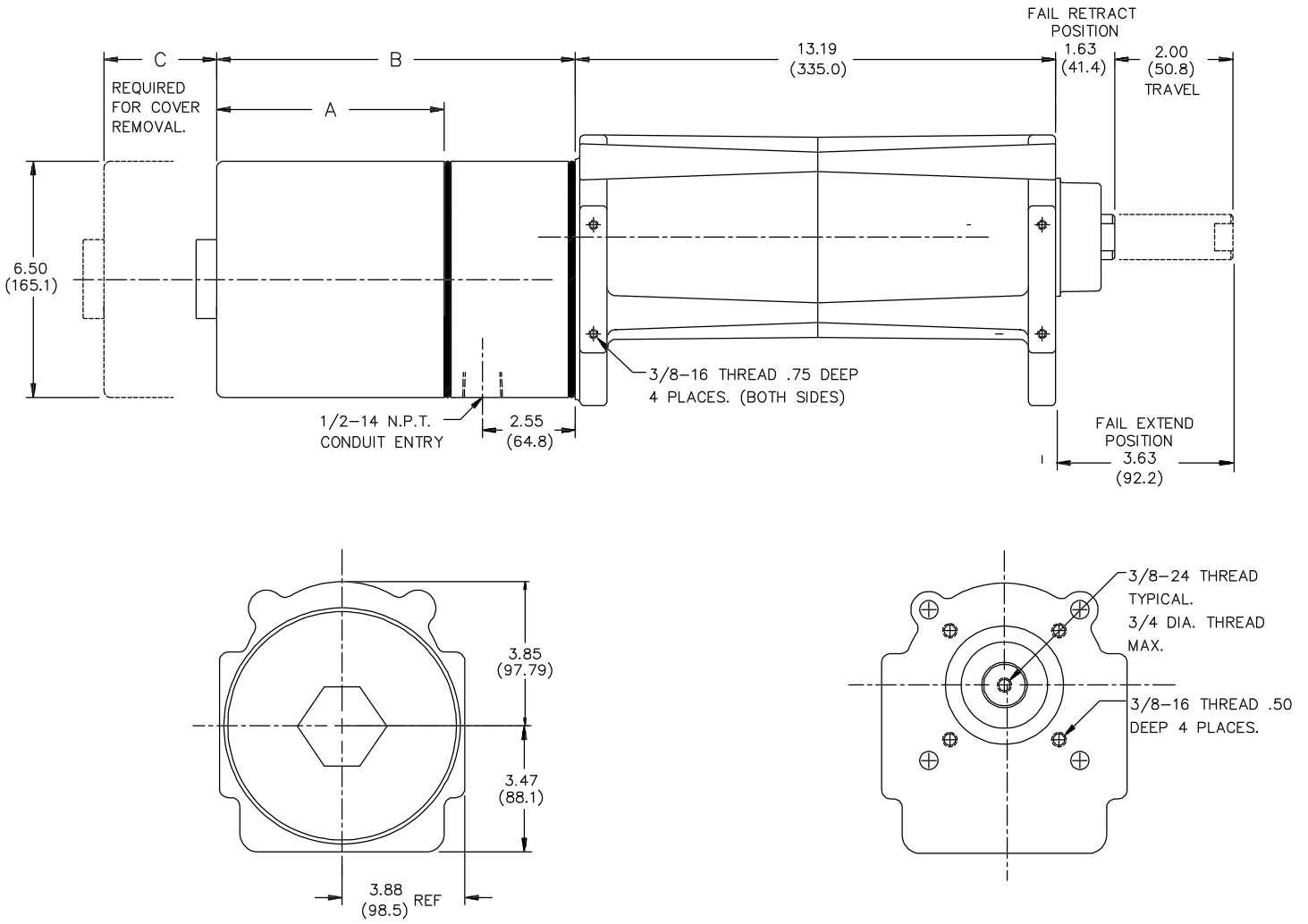

	A	B	C
Without Amplifier	6.88 (174.7)	9.86 (250.4)	7.00 (177.8)
With Amplifier	10.00 (254)	12.98 (329.7)	10.13 (257.3)

# SM-3330 Major Dimensions

DIMENSIONS INCHES  
( MM )

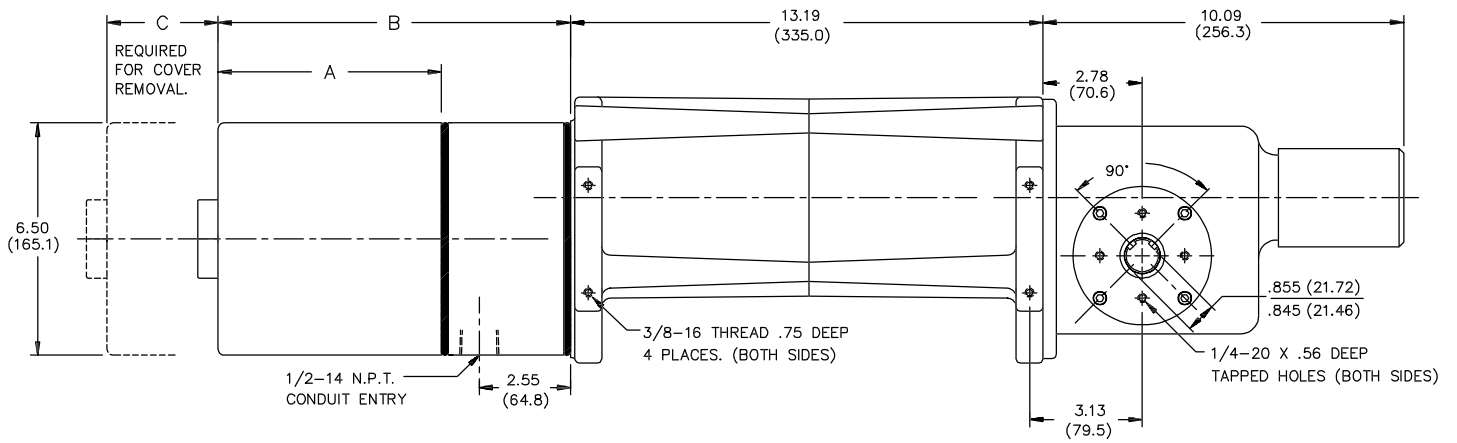

NOTE:  
KEYWAY LOCATION CORRESPONDS TO FAIL CW POSITION.  
OUTPUT SHAFT: 1.000/.998 (25.4/25.34) DIA.  
KEYWAY: .251/.253 WIDE

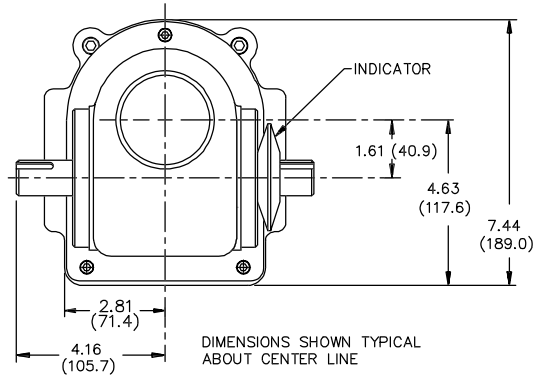
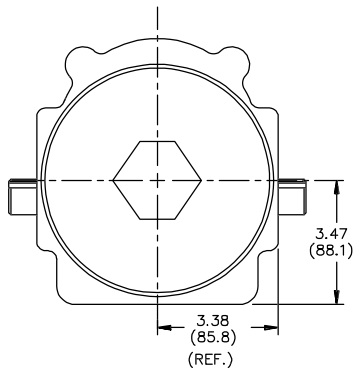

	A	B	C
Without Amplifier	6.88 (174.7)	9.86 (250.4)	7.00 (177.8)
With Amplifier	10.00 (254)	12.98 (329.7)	10.13 (257.3)





# Typical SM-LA-3330 Wiring Diagram

