

rotork®



Nuclear Electric Actuators



rotork® Nuclear



Actuation Solutions for Nuclear Powerplants

Established Leaders in Actuation Technology

Contents

Section	Page	Section	Page
1 Introduction	4	5.6.1 Local position indicator dial	11
1.1 What Rotork Type N means		5.6.2 Remote position indication	
1.2 Design qualification basis		5.6.3 Six switch Add-on-Pak 1	
1.3 Quality assurance		5.6.4 12-Switch Add-on-Pak 1	
1.4 Non-safety related actuators		5.6.5 Customer's cable connections	
2 Design specification	5	5.6.6 Thread adaptors (optional extra)	
2.1 Passive duty		5.6.7 Standard wiring diagrams	
2.2 Reliability considerations		6 Specific qualification of manufactured actuators	12
2.2.1 Environmental sealing of Type NA actuators		6.1 Quality Assurance program for type NA actuators	
2.2.2 External cable connections		6.2 Procurement of commercial grade components for safety related application	
2.2.3 Separate terminal box		6.3 Lot control and material traceability of safety related components	
3 Design Qualification	7	7 Valve Protection	13
3.1 Qualification basis		8 Exeeco nuclear safety related gearboxes	13
3.1.1 Type NA1E actuators		8.1 IWN quarter turn gearboxes	
3.1.1.1 Qualification tests		8.2 IBN multi-turn bevel gearboxes	
3.1.1.2 NA1E actuator qualification test parameters		8.3 ISN multi-turn bevel gearboxes	
3.1.2 Type NAB1E, NAB5E		9 Documentation	14
3.2 Equipment qualified		9.1 Additional documentation	
4 Mechanical Construction	9	10 Maintenance of qualified actuators	14
4.1 Housings		11 Actuators for non-safety related duties outside containment	14
4.2 Manual operation		12 Conventional valve duties	15
4.3 Principal materials		13 Ordering information	15
5 Electrical construction	11		
5.1 Motor			
5.2 End position switches			
5.3 Cable			
5.4 Heater			
5.5 Terminals			
5.6 Position indication			

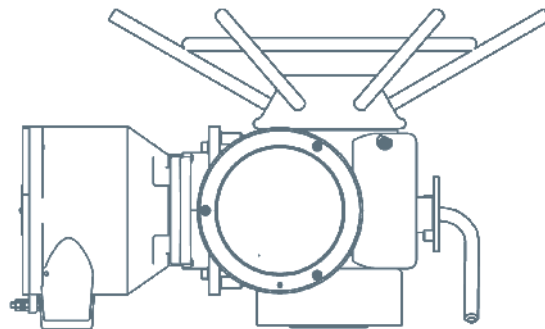

rotork® Controls

Rotork is a global leader in valve actuation technology. We provide a comprehensive range of valve actuators, controls and associated equipment, as well as a variety of valve actuator services including commissioning, preventive maintenance and retrofit solutions.

We strive always for technical excellence, innovation and the highest quality standards in everything we do. As a result, our people and products remain at the forefront of actuation technology.

Uncompromising reliability is a feature of our entire product range, which includes pneumatic, hydraulic and electro-hydraulic actuators, as well as gear boxes and valve accessories. We manufacture to the highest standards at plants located in Europe and North America.

Rotork is committed to providing first class support to each client throughout the whole life of their plant, from initial site surveys to installation, maintenance, audits and repair. From our network of national and international offices, our engineers work around the clock to maintain our position of trust.

Rotork. Established leaders in valve actuation technology.



rotork®
Controls

rotork®
Fluid Systems

rotork®
Gears

rotork®
Site Services

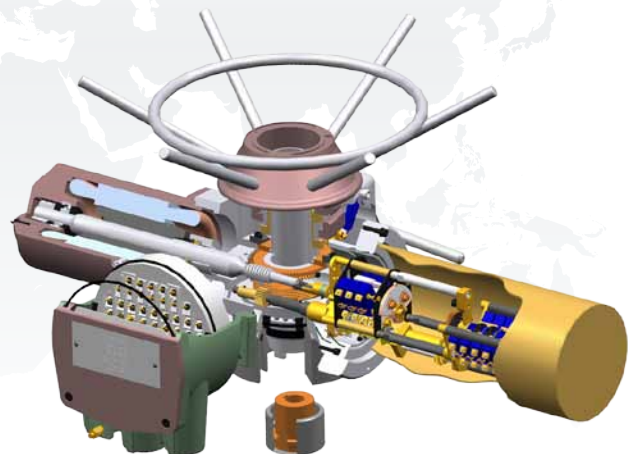

1 Introduction

Electric motor and manually operated valves feature prominently in the centralized control systems of nuclear power generating stations and make a major contribution to the economy, efficiency, reliability and safety of the station in which they operate. The emphasis on safety has raised the level of technology required for a wide range of equipment associated with these systems.

Rotork has been involved in the supply of electric valve actuators for installation in nuclear power plants since the late 1960s. Rotork has been a participant member of the sub-committees of the US Standards Committee responsible for drafting various standard IEEE 382 since the 1970s.

Generally the categories of safety related duty valve applications are as designated as Class 1E in standard IEEE 323 and defines as equipment and systems that are essential to emergency reactor shutdown, containment isolation, reactor core cooling and containment and reactor heat removal, or otherwise essential in preventing significant release of radioactive material to the environment:

- a Inside containment - active
- b Inside containment - passive
- c Outside containment - active
- d Outside containment - passive

Where 'active' refers to valves which have to operate during and after reactor emergency and 'passive' refers to valves which do not have to operate but must maintain their structural integrity during and immediately after an emergency. Conditions associated with the outside containment valve are far less severe than for the inside containment active units, Rotork has designed the following specification for the NA ranges of nuclear actuators intended to suit these applications as follows:

Specification NA1E Type - For inside containment active or passive duty

Specification NA5E Type - For outside containment active duty

Different reactor designs give rise to different environmental conditions and the final choice of actuator specification must be based on the requirements of the particular application.

1.1 What Rotork Type N means

The prefix designation N is only applied by Rotork to an actuator or gearbox design which has been qualified for safety related duties in nuclear power plants, and is manufactured under strict quality control conditions which ensure that:

The design standard qualified generically by type test is maintained during manufacture, and:

The specific requirements of the application are met.

1.2 Design qualification basis

The basis of qualification of Rotork type NA actuators is the IEEE 382 – 1996 – "IEEE Standard for the Qualification of Actuators for Power-Operated Valves Assemblies with Safety-Related Functions for Nuclear Power Plants" which specifies procedures and test methods for the environmental qualification of valve actuators.

The levels of qualification for the actuators are given in Section 3.

1.3 Quality assurance

All Rotork type NA actuators are manufactured to a quality assurance programme which meets the requirements of the relevant sections of the following Standards as detailed in Rotork quality system manual:

10 CFR 50 Appendix B

ASME NQA-1

CSA Z299.1

QA 42.1

ISO 9000-2000

1.4 Non-safety related actuators

Where motorised valves are not designated as safety related, normally standard Rotork A Range SyncroPak and SyncroSet or IQ or IQT actuators remain the most obvious choice for installed economy and reliability.



2 Design Specification

The design of the NA range is a development of the Rotork standard 'A' Range SyncroSet generally described in Publications E210E and E262E. Each actuator comprises an oil bath worm gearbox with integral three phase squirrel cage motor, torque and limit switches and a separate terminal compartment to which all electrical components are wired. These specification notes refer to those features which are special for nuclear duty or important for other reasons. While these design qualifications are based on conditions postulated for pressure containments of PWR and BWR plants, their use can be extended to other reactor designs wherein normal and abnormal conditions fall within the limits specified.

Type NA1E and NA5E actuators are designed for use with leadscrew operated valves where the stem thrust has to be taken in the actuator, which is type 'A' as per standard ISO 5210. The actuators are however also suitable for non thrust applications. Alternative systems of mounting dimensions are available with NA1E, and NA5E actuators as follows:

ISO5210 — Multiturn

ISO5211 — Part-turn (IWN Gearbox)

MSS SP-101 — Part-turn (IWN Gearbox)

MSS SP-102 — Multi-turn

Type NAB1E and NAB5E actuators are for non-thrust taking applications and are designed to meet the requirements for type 'B' couplings to ISO5210. It is assumed that the valve manufacturer will supply any coupling adaptors necessary to achieve a drive from the type 'B' actuator output bore to his valve stem.

Rotork NA actuators can also be assembled to second stage gearboxes. These have the designations IWN for quarter turn gearboxes, IBN for bevel gearboxes and ISN for spur gearboxes. All have the same qualification levels as the actuators.

1 Design life

The actuators are designed for a working life of 40 years based on the following total number of operating cycles:

NA1E type - 4,000

NA5E type - 4,000

IWN, IBN, ISN gearboxes - 4000

An operating cycle is defined as moving the valve from the open position to the close position and back to the open position. The actuator is set to torque operation in the close position and limit operation in the open position. The torque setting at the close position is actuator rated (maximum) torque. During travel, an average load of 33% of the rated torque is applied.

2 Design environment

Normal conditions

All NA actuators are capable of operation for 15 minutes in any one hour (unless otherwise specified) at average valve load under the following conditions:

Ambient pressure	8 psig to 18 psig
Humidity	100% RH
Temperature	60 °C (148 °F)
Standard radiation life accumulated dose with no change of components	1.50E+05 Gy 1.50E+07 Rad
Plant induced vibration	0.75g all frequencies

Accident conditions

NA1E type and NA5E type actuators are capable of a minimum of 20 operations during and following exposure to the following conditions (see LOCA temperature and pressure - time test profiles in Qualification Test Summary).

Actuator Type	NA1E	NA1EDC	NA5E, NA5EDC
Ambient Pressure (maximum)	87 psig, 6.0 barg	15 psig, 1.0 barg	10 psig, 0.7 barg
Ambient temperature (maximum)	188°C (370°F)	70°C (160°F)	70°C (160°F)
Atmosphere:	Yes	No	No
Saturated air and steam mixture with chemical spray consisting of (typically) 0.28 molar H3BO3 (6,200 ppm boron), 0.064 molar N2S2O3, and NaOH to make a pH of 10.5 at 25°C (77°F) (about 0.59%).			
Seismic acceleration in any direction	8g	8g	8g
Seismic frequency range	0.2-34Hz	0.2-34Hz	0.2-34Hz
Radiation life	2.00E+06 Gy	2.00E+05 Gy	3.00E+05 Gy
accumulated dose	2.00E+08 Rad	2.00E+07 Rad	3.00E+07 Rad

2.1 Passive duty

Type NA1E actuators are used for Class 1E passive duty inside containment.

Standard A Range actuators are suitable for passive duty outside containment areas where seismic acceleration levels are 6g or below.

Type IQ and IQT are also suitable for passive duties outside the containment areas where the seismic acceleration levels are 6g or below.

2 Design Specification

2.2 Reliability considerations

Electric valve actuators are normally inactive. Even in conventional plant applications where the valve is in regular use, most actuators are idle 99.99% of the time. In safety related systems, the operating frequency and duration is even lower, being dictated almost entirely by the plant periodic test programme. It is therefore obvious that the ultimate reliability of electric actuators depends fundamentally on how well the electrical components are sealed from the external environment. While this applies generally, the importance of proper sealing cannot be over-emphasized for safety related actuators installed within a nuclear containment. In these applications, the ambient temperature, pressure and humidity will rise to extreme levels during a Design Basis Event (DBE) during which the motorised valves must perform their safety related function.

2.2.1 Environmental sealing of Type NA actuators

All Rotork electric actuators feature 'O' ring sealed sleeve jointed water-tight and dust-tight enclosures as standard. With the 'O' ring sealed covers in place, the motor, limit and torque switches and any other electrical components are housed within a pressure tight enclosure, which not only excludes dirt and moisture, but also prevents breathing due to expansion and contraction of the internal air with temperature changes. This eliminates the problems of condensation build-up arising with traditional flange-jointed electrical enclosures. The only condensation which can occur is of the moisture in the original air content which is insignificant.

2.2.2 External cable connections

Even with an enclosure of such a high standard, a significant reliability problem remains if the design allows the customary direct entry of external wiring conduits into the enclosure, which must then be opened for wiring on site. This is a major source of subsequent unreliability due to ingress of moisture and dirt during adverse installation conditions. Even if the work is completed and covers replaced under ideal conditions, the long term environmental protection then depends entirely on the quality of sealing of the conduit entries by the installation contractor. Obtaining good sealing is difficult enough with normal environments; the exceptionally high temperature and pressure steam ambient within the containment during a DBE will test the best conduit sealing to the utmost.

The use of plug and socket cable terminations at the actuator increases the risk of circuit continuity failure. This type of cable termination was not included in the Rotork nuclear actuator qualification test program.

2.2.3 Separate terminal box

All Rotork Type NA actuators feature a separate terminal compartment in which the substantial cylindrical terminal block is itself a pressure retaining wall, with 'O' ring seal to its housing. Thus the electrical components within remain sealed from the environment during wiring on site, with the conduit sealed in place, spare entries plugged and sealed and the terminal cover and 'O' ring fitted, the enclosure is 'Double Sealed', so that leakage through conduit seals can only affect the terminal compartment itself (Figure 2.2).

During environmental qualification testing (Reference: NLI QR-29001-2) conduit entry leakage was simulated during the Loss of Coolant Accident test. The actuator continued to operate during and after the test demonstrating the effectiveness of the 'Double Sealing' feature.

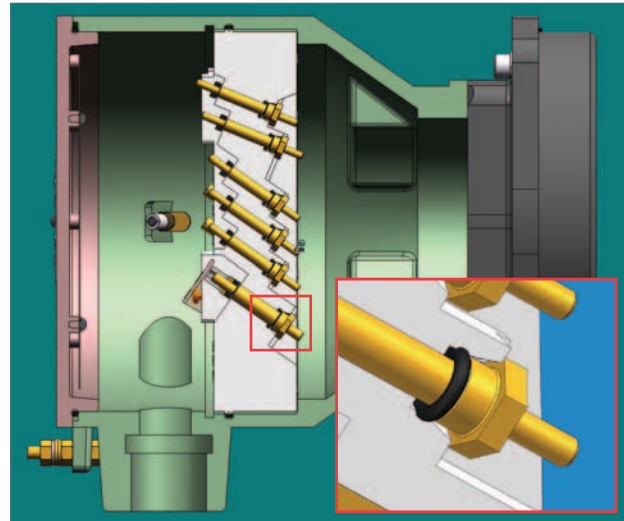

Figure 2.1 Nuclear terminal block showing sealing system.

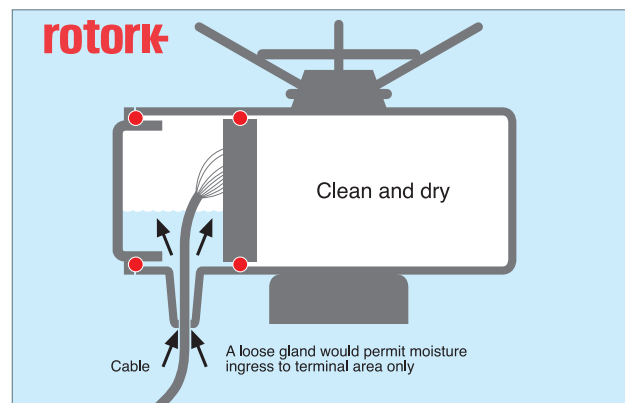
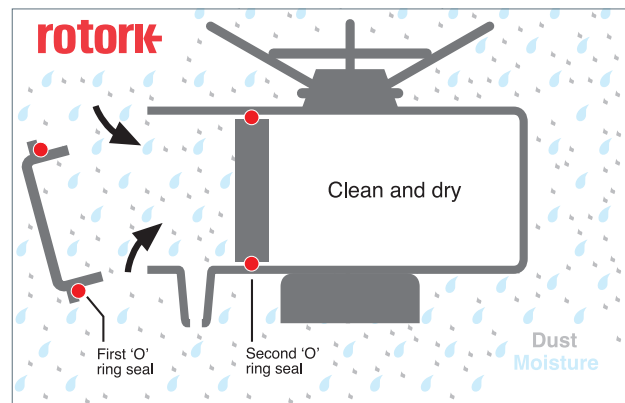

Figure 2.2 Rotork Double Sealing Solution

3 Design Qualification

The object of nuclear environmental qualification is to provide auditable evidence that the actuators are capable of meeting their performance specifications under normal environments and under those conditions experienced during a Design Basis Event (DBE).

3.1 Qualification basis

3.1.1 Type NA1E actuators

3.1.1.1 Qualification tests

Rotork NA1E nuclear specification actuators have been environmentally qualified in accordance with IEEE-Std-382. The basis of this qualification is a series of comprehensive tests conducted by Wyle Laboratories, Nuclear Logistics Inc, Trentec Inc USA and Kinectrics, Canada.

The applicable qualification test reports are: -

Wyle Laboratories, Huntsville, Alabama. USA	43979-1 43979-3 58364
Nuclear Logistics Inc; Dallas, USA	QR-029001-2 QR-029001-3 QR-029001-5 QR-029001-6 QR-029001-7
Kinectrics Inc; Toronto, Canada	3550
Thermodyne Laboratories Inc; Toronto, Canada	01R-02-02
Trentec Inc; Cincinnati, USA	0Q020.0 2Q002.0 0Q018.0 0Q007.0

See Publication E257E for details of the test laboratories and the summary of the environmental qualification test done.

See Publication E251E for copies of test certificates.

3.1.1.2 NA1E actuator qualification test parameters

a) Normal Radiation aging - 70.00E+04 Gy (70.00E+06 RAD).

b) Mechanical wear aging - 4,000 cycles (environmental aging).

c) Thermal Aging (Parameters derived using Arrhenius Law 125 °C (257 °F) for 16 days).

d) Pressurisation aging - 15 cycles of 3-minute duration at 65 psig.

e) Resonant search - A low-level (0.2g) resonant search from 1 to 100Hz and at one octave per minute.

f) Plant induced vibration aging - Biaxial sinusoidal motion of 0.75g with a frequency of 10 to 100 to 10Hz at a rate of two octaves per minute. Ninety minutes of vibration in each orthogonal axis.

g) Seismic - RMF test - A random multifrequency test with a 30-second duration simultaneous horizontal and vertical phase - incoherent inputs of random motion consisting of

frequency band widths spaced one-third octave apart over the frequency range of 1Hz to 100Hz as necessary to envelope the required response spectra (see Figure 3.1). Five OBE level tests (three-fourths of SSE level) and one SSE level test in each orientation.

h) Safety Relief Valve duty aging test - Test specimen was subjected to a minimum of 8400 stress cycles.

i) Upset and Faulted Loading aging test - A series of multi-frequency tests upset followed by faulted tests of 30 second duration in accordance with IEEE-std-344. 20 upset seismic fatigue test runs were performed followed by 4 faulted test runs. In all more than 5 stress cycles were carried out.

j) DBE Radiation - 130.00E+04 Gy (130.00E+06 RAD).

k) DBE Environmental test - A steam exposure profile (see Figure 3.2) for a LOCA simulation representing PWR and BWR in-containment service.

l) Seismic - RIM test - Two OBE tests with a sinusoidal sweep from 2 to 35 to 2Hz in each axis at a rate of one octave per minute and a level of two-thirds of the required input motion. One SSE in each axis consisting of a continuous series of single frequency sine beat tests at the one-third octave interval test frequencies and test levels indicated in IEEE 382 1980 (see Figure 3.3).

Note: No significant change was found in the results of the baseline function. Tests were performed after each portion of the type test.

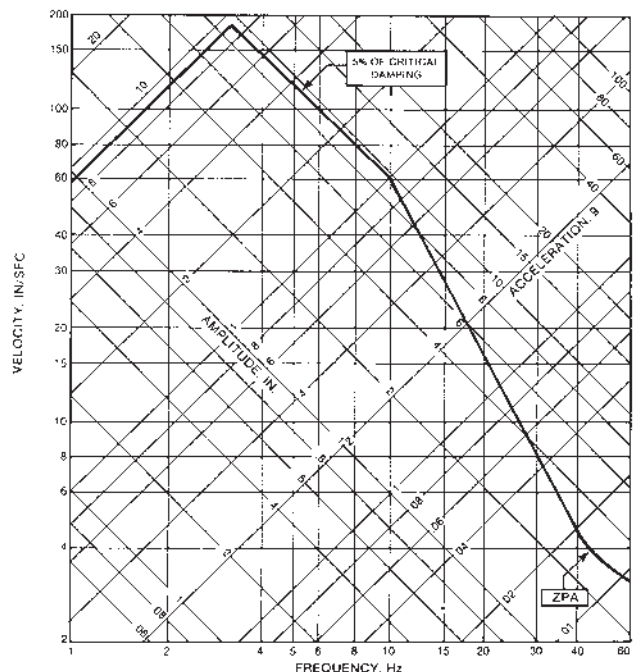

Fig. 3.1 Seismic qualification, required response spectrum (IEEE 382 1996).

3 Design Qualification

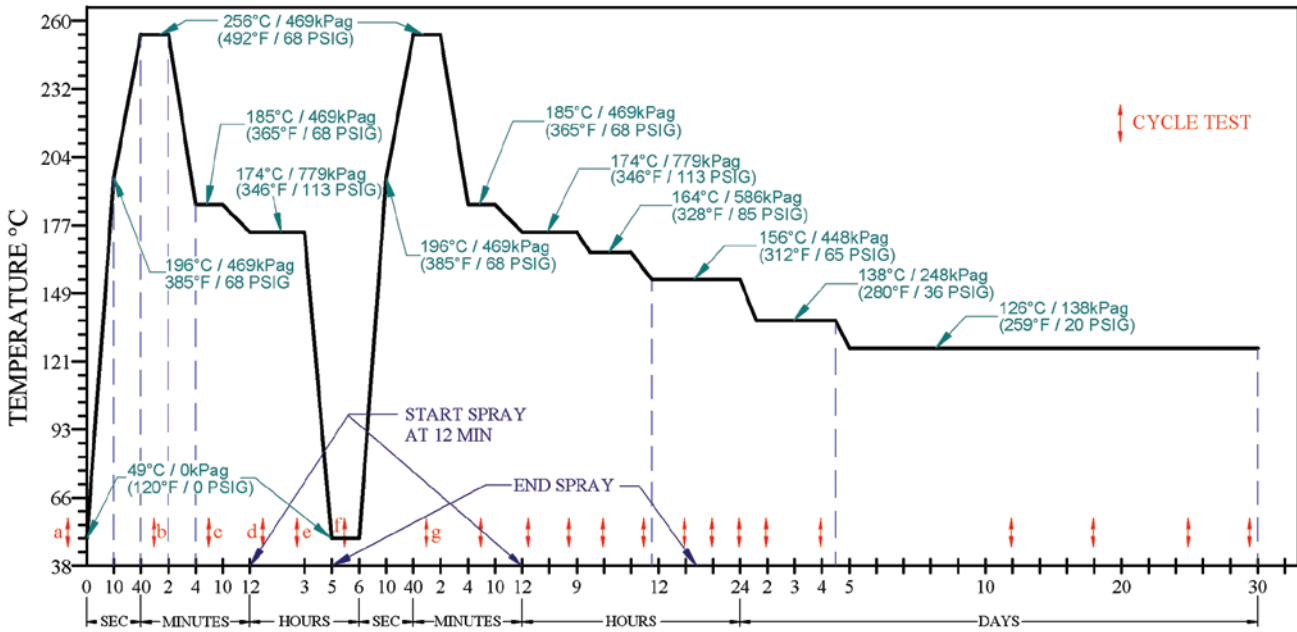

Fig. 3.2 Environmental qualification parameters.

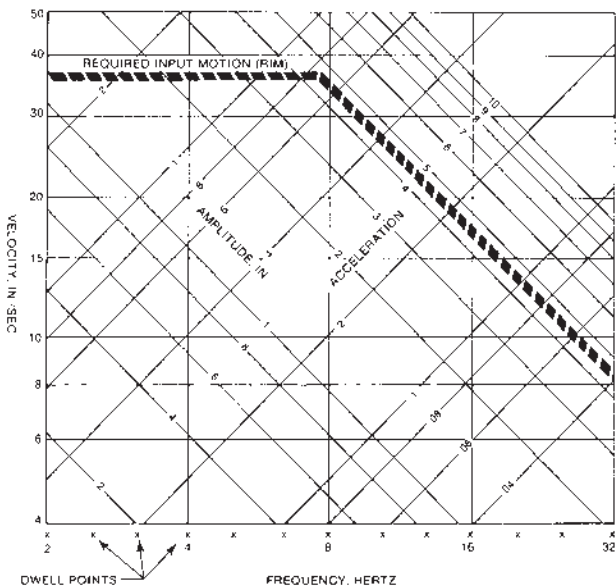

Fig. 3.3 Seismic qualification Required Input Motion (IEEE 382 1996).

IWN gearboxes have been subjected to full environmental qualification testing. The IBN and ISN gearboxes and actuator assemblies have been seismically tested. The IBN and ISN gearboxes contain identical non-metallic materials as the IWN gearboxes and are therefore environmentally qualified by similarity analysis (see Publication E253E for a summary of the environmental qualification performed).

The qualification testing conducted on type NA1E actuators and IWN, IBN & ISN gearboxes provides the basis for the highest level of confidence because of the following features:

a) Representative test specimens of the actuator and gearbox generic groups were selected using the 'Method of Selection of

Representative Actuators for Type Testing" outlined in Annex A of IEEE-Std-382.

- b)** The environmental qualification tests were performed by independent 10CFR50 Appendix B accredited laboratories.
- c)** Live hot steam was used during DBE simulation.
- d)** Actuators and gearboxes were tested.
- e)** The seismic testing performed on the actuator/gearbox combinations resulted in the worst-case conditions for the actuator due to its centre of gravity being further from the test rig mounting flange.
- f)** Safety Relief Valve tests were conducted at 8g ZPA in addition to the seismic test requirements of IEEE-Std-382.
- g)** Upset and Faulted loading tests were conducted at 8g ZPA in addition to the seismic test requirements of IEEE-Std-382.
- h)** Hydrodynamic Chugging tests were conducted at 8g ZPA in addition to the seismic test requirements of IEEE-Std-382.
- i)** A separate main steam line break simulation was performed after the DBE test had been completed.
- j)** Baseline functional testing was performed after each phase of the test programme verifying that the actuator performed as it did during the receipt inspection.

3.1.2 Type NAB1E, NAB5E

These actuator designs are qualified on the basis of the Nuclear Qualification Reports for the Type NA1E actuators referenced in Section 3.1.1.1 above and through extrapolation, analysis and/or testing.

3.2 Equipment qualified

Design qualification is established for the range of actuator sizes with output speeds and rated torques up to the values given in Section 2.2 and with the electrical and mechanical features described in sections 4 and 5. Qualified actuator and gearbox combinations and performance are shown in Publication E252E.

4 Mechanical Construction

4.1 Housings

All actuators are produced in watertight form, enclosure classification IP67 to IEC 529 (NEMA 6, BS5490 and DIN 40050 equivalents). The motor and switch enclosure is completely sealed from outside environments and also from the terminal compartment. The gearcase is oil filled and suitable for operation with the valve at any mounting orientation, oil retention being by dynamic lip seals and static 'O' ring seals. A breather is fitted to the gearcase of NA1E type actuators to effect pressure equalisation across the seals and prevent lubricant displacement under high ambient pressure or temperature conditions.

4.2 Manual operation

The emergency handwheel drive, engaged by de-clutch lever and disengaged automatically when the motor starts, is mechanically independent of motor drive and gearing.

It is direct-acting for maximum efficiency and speed in top-handwheel form (standard for 7NA through 40NA). 70NA and 90NA have geared side handwheels as standard. Geared side-handwheels are available as an optional extra for 14NA through 40NA.

Note: To avoid overgearing of handwheels, the motor gearing is not used.

4.3 Principal materials

The materials used in the construction of the actuators are given in table 1.

The main differences in materials used for N type nuclear specification actuators as compared with those used for standard 'A' type are as follows:

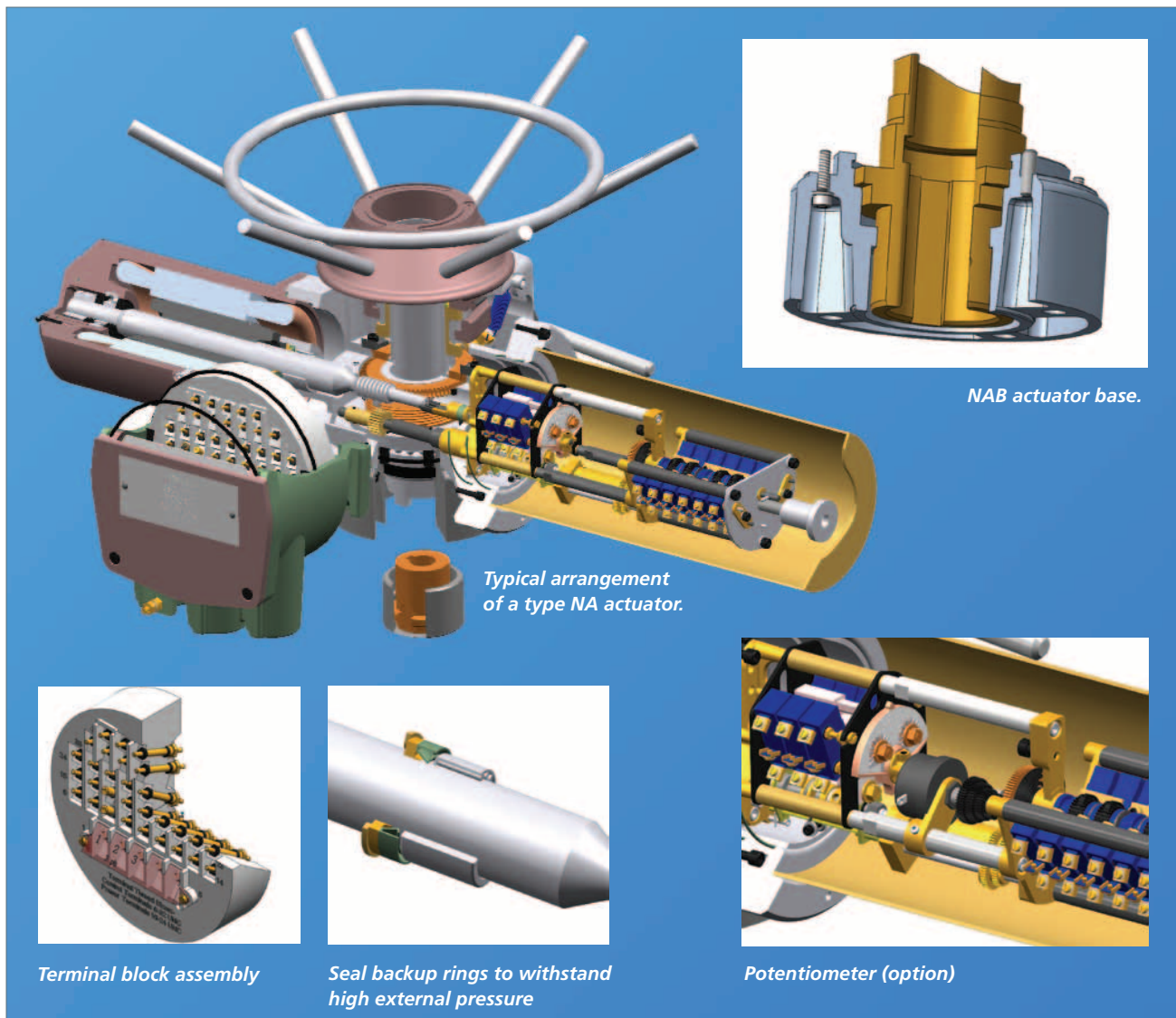

4 Mechanical Construction

Table 1 - Nuclear product material specification

Component	NA1E	NA5E	'A' Range
Gearcase	Grey cast iron and/or malleable	Grey cast iron and/or malleable	Grey cast iron and/or malleable
Dynamic oil seals	Viton with pressure backup rings	Viton with pressure backup rings	Medium nitrile
Static 'O' ring	Viton	Viton	Nitrile
Paint system	Carbozinc 11 Undercoat Phenoline 305 topcoat (Publication E258E)	As 'A' Range	Chromatic primer Acrylic reinforced Synthetic alkyd topcoat
Lubricant	Radiation resistant oil	SAE 80 EP oil	SAE 80 EP oil
Motor housing	Grey cast iron	Grey cast iron	Aluminium with alchrome coating
SyncroSet housing	Grey cast iron	Grey cast iron	Aluminium with alchrome coating
Handwheel	Hot rolled steel	Hot rolled steel	Hot rolled steel
Drive bush (1)	Aluminium bronze	Aluminium bronze	Aluminium bronze
Drive bush retainer (1)	Zinc plated high-duty wrought steel	Zinc plated high-duty wrought steel	Zinc plated high-duty wrought steel
Motor insulation	Class H	Class H	Class B
Overload protection	Customers relay	Customer's relay	Thermostat
Switch/Mech switches	Burgess V-12	Burgess V- 12	Burgess TK-5
AOP switches	Burgess V-12	Burgess V-12	Honeywell (std)
Cable Insulation	Nuclear qualified	Nuclear qualified	High temp. PVC (2)
Potentiometer	Ohmite nuclear	Ohmite nuclear	Colvern (std)
Local position Indicator	Not available	Not available	Standard pointer and dial
Heater	12 Watt	12 Watt	12 Watt

1 - Type NAB actuators as standard are not provided with a drive bush.

2 - Cross link Polymeric wire is available as an option.

5 Electrical Construction

5.1 Motor

Integral three-phase squirrel cage stator - rotor unit specially designed and rated for valve operation, wound as standard for one of the following voltages:

60Hz 460 or 575 volts

50Hz 380, 415 or 500 volts

NA1E and NAB1E motors are sized to permit torque switch operation at maximum design torque allowing for performance variations due to voltage drop and high temperature operation (See Publication E252E for guide to sizing for safety related duty). Overload protection: by customer's thermal relay.

5.2 End position switches

Torque and limit switches have self-wiping contacts of half-hard brass plated with .01" thick fine silver. Torque switch setting adjusters have 10-position 'lock and block' feature with numbered setting label to provide recorded tamper-proof settings.

The switch case material used on type NA1E, NA5E is DAP (Diallyl Isophthalate) plastic.

5.3 Cable

Stranded tinned copper conductor of 18 AWG (33/0.19mm) on 7/11NA motor and 12 AWG (11 10/1. 1.9mm) on 14-90 NA motors, 18 AWG (33/1.9mm) for control on all actuator sizes.

Cables used on type NA1E, NA5E have class H, radiation resistant sheaths.

5.4 Heater

12 Watt ceramic resistor wound for either 125 volts or 240 volts.

5.5 Terminals

Angled studs through cylindrical moulded block of thermo setting DAP (Diallyl Isophthalate) with 'O' ring seal to housing providing water and steam tight barrier, maintaining integrity of electrical component sealing regardless of conduit entry sealing (see para. 2.4.2). Power terminals are 10-24 UNC, and control terminals are 6-32 UNC. All terminals are stainless steel and are provided with locking hardware and power terminals screened by insulating cover.

5.6 Position indication

5.6.1 Local position indicator dial

Not available (use stemrod if required).

5.6.2 Remote position indication

Basic switch mechanism provides two auxiliary switches at each end of travel for remote position indication, in addition to the switches, which provide torque and/or position limitation to suit the type of valve (6 switch total). Since safety related valves are normally associated with isolating duty, for which fully open/closed position indication only is usually adequate, potentiometer transmitters for continuous position indication are usually not required but are available as indicated below.

Inside Containment accident temperatures and radiation levels are too severe for the electronic resistance/current transducers necessary to provide analogue current position signals and, when these are required therefore, Rotork assumes the transducers will be supplied by others for mounting outside containment.

5.6.3 Six switch Add-on-Pak 1

Six switch Add-on-Pak 1, providing two additional sets of three high accuracy microswitches tripped by cams at any two independently adjustable valve positions (12 switches in total) and wire wound potentiometer position transmitter for operation at 3 watt maximum.

The switch case material used on type NA1E, NA5E is DAP (Diallyl Isophthalate) plastic.

The Potentiometer has a maximum rating at 25 Watt 20 °C (70 °F) to allow 3 watt usage at maximum ambient.

5.6.4 12-Switch Add-on-Pak 1

This provides four independently adjustable position-setting cams, two operating two switches each and two operating four switches each giving 18 switches in total. Materials and specification as for six switch:

5.6.5 Customer's cable connections

Three tapped conduit entries are provided, 2 x 1 1/4" ASA and 1 x 1 1/2" ASA NPT 1 1/2 tpi, supplied with threaded plugs. These should not be removed from unused entries.

5.6.6 Thread adaptors (optional extra)

Conduit Thread Adaptors are available to order, supplied separately bagged leaving ASA entries sealed by threaded plugs until required.

Cable connections may be made by conduit, mineral insulated cable or flexible cable using glands or adaptors supplied by others. The threads must be properly sealed by the wiring contractor who should also make off wire ends with appropriate ring tongue terminations to suit the terminal studs.

5.6.7 Standard wiring diagrams

Wiring diagram numbers for standard versions of NA1 actuators are as follows:

	Type NA1E	Type NA5E	Type NA1EDC	Type NA5EDC
Basic Actuators:	2020VNO	2220VNO	4020VNO	4220VNO
Add-on-Pak 1: with 6 switch	2021VNO	2221VNO	4021VNO	4221VNO
Add-on-Pak 1: with 12 switch	2029VNO	2229VNO	4029VNO	4229VNO

6 Specific qualification of manufactured actuators

Design qualification shows that the generic design basis is suitable for the intended purpose, exemplified by type tests of particular units.

Rotork quality systems ensure that each NA type actuator is manufactured to the qualification design standard.

- a) The actuators are sized and chosen to meet the specific application.
- b) The components used in the manufacture have traceable and auditable links to the qualified design standard.
- c) Every Rotork actuator is performance tested to ensure it meets the specified requirements. In the case of NA type actuators, this includes tests to demonstrate that it will perform at the DBE levels of high temperature and reduce voltage.

6.1 Quality Assurance program for type NA actuators

The Rotork quality system details all the procedures and documentation utilised for both standard and nuclear actuators. The program for type NA actuators has been evolved in co-operation with utilities and architect-engineers responsible for construction and operation of nuclear power stations.

The Rotork quality assurance program is designed to meet the requirements of 10CFR50 Appendix B, ASME NQA-1, CSA 2299.1, and QA 42-1 to insure that:

- 1 Type NA actuator components are only supplied by vendors whose own quality systems and performance are under the surveillance of and approved by Rotork quality manager.
- 2 Safety related components are manufactured from certified materials.
- 3 Safety related components are kept in a separate bonded store.
- 4 Design qualification is maintained during manufacture and unqualified modification is forbidden.
- 5 Specific application requirements and sizing data for each actuator are recorded.
- 6 Assembly of each type NA actuator is carried out under specific procedures and the work is traceable.
- 7 Specific actuator performance is tested and recorded.
- 8 Safety related components are traceable through the supply chain and to installed actuators.
- 9 A certificate of compliance is signed by the quality manager or designee only when he has auditable evidence that all these requirements have been satisfied.

6.2 Procurement of commercial grade components for safety related application

When possible, Rotork purchases safety related components from suppliers certified to 10CFR50 Appendix B quality systems. Where this is not possible, Rotork purchases commercial grade items to the guidelines specified in Electric Power Research Institute (EPRI) document NP-5652 – ‘Guidelines for the Utilisation of Commercial Grade Items in Nuclear Safety Related Applications’.

6.3 Lot control and material traceability of safety related components

All safety related components are lot controlled and are traceable to the actuators to which they are fitted.

Records are maintained via the manufacturing system and are available for the life of the plant.

All safety related components are stored in a bonded store insuring that material traceability is maintained.

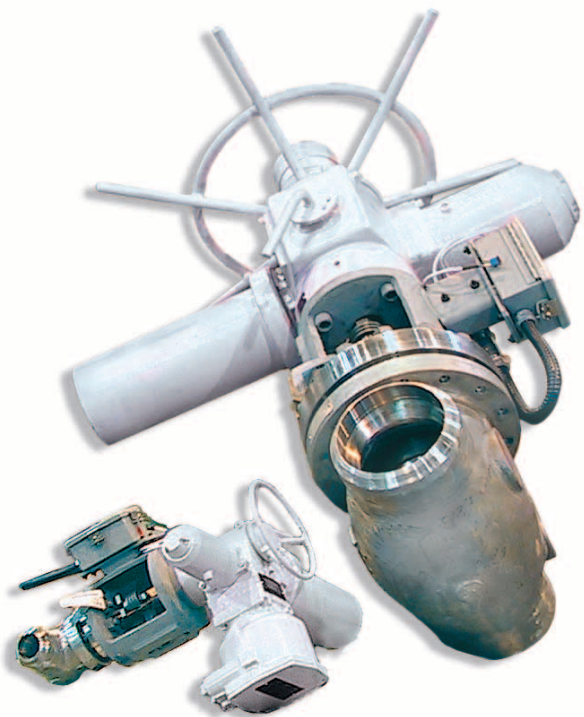

7 Valve Protection

8 Exeeco nuclear safety related gearboxes

7 Valve Protection

An actuator sized to perform under DBE conditions will produce very high torque at normal ambient conditions and nominal voltage. The valvemaker is notified of the approximate stall torque to which the valve may be subjected under these conditions. In situations where as a result of this the valve safety margins are reduced the valvemaker should consider the use of a torque limiting brake (as described in Publication E254E) or a thrust compensator (as described in Publication E255E) for the protection of the valve when voltage drops of more than 10% are specified even if fast operation of the valve does not apply.

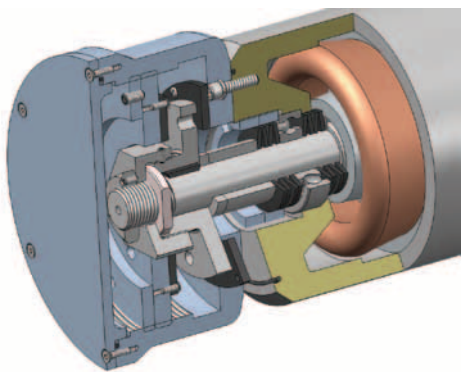

Fig. 7.1 Torque limiting brake

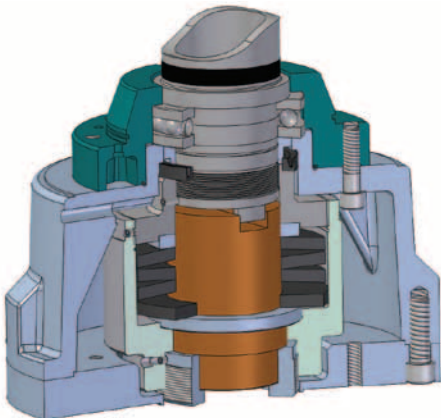

Fig. 7.2 Thrust compensator

8 Exeeco nuclear safety related gearboxes

Rotork NA1E and NA5E actuators can be offered in combination with Exeeco gearboxes qualified for nuclear safety related duty. Designation of Exeeco safety related gearboxes are suffixed with 'N'. Publication E252E contains the sizing guides for IWN, IBN and ISN gearboxes.

8.1 IWN quarter-turn gearboxes

A range of nuclear safety related heavy-duty cast and ductile iron, quarter-turn worm gearboxes. Suited for plug, ball and butterfly valves.

The IWN gearbox range comprises 7 sizes with ratios of 40:1 and 70:1 and a torque range of up to 30487 Nm (22500 lbsft).

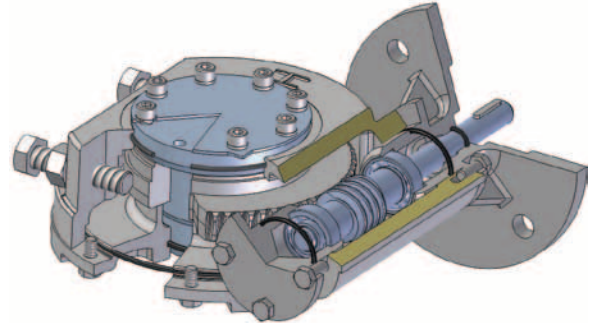

Fig. 8.1 Exeeco IWN quarter-turn gearbox

8.2 IBN multi-turn bevel gearboxes

A range of nuclear safety related heavy-duty cast iron multi turn bevel gearboxes suited for the most demanding linear valve applications.

The IBN gearbox range comprises 6 sizes with ratios of 2:1 to 8:1 and a torque range up to 5528Nm (4080 lbsft) and a thrust range up to 1,557kN (350,000 lbs).

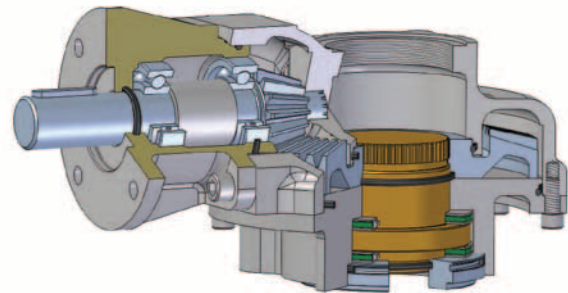

Fig. 8.2 Exeeco IBN bevel gearbox

8.3 ISN multi-turn spur gearboxes

A range of nuclear safety related heavy-duty cast iron multi turn spur gearboxes suited for the most demanding linear valve applications as an alternative to the IBN gearboxes where higher torque and thrusts and larger stem acceptance is required. The ISN gearbox range comprises 3 sizes with ratios of 8:1 to 24:1 and a torque range up to 36721Nm (27100 lbsft) and a thrust range up to 1,557kN (750,000 lbs).

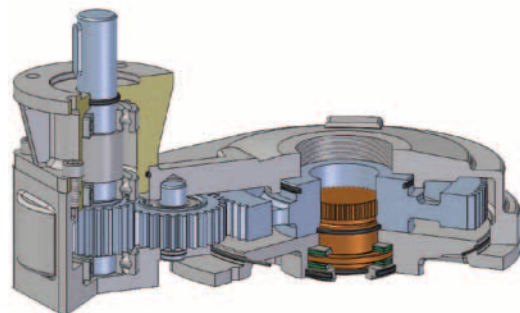

Fig. 8.3 Exeeco ISN spur gearbox

9 Documentation

10 Maintenance of qualified actuators

9 Documentation

Documentation is supplied as standard for each NA actuator as follows:

- a) Performance Test certificate (QC1)
- b) Certificate of Compliance (QC2/K)
- c) Installation drawing giving C of G data
- d) Wiring diagram.
- e) Paint certification

9.1 Additional documentation

All customer specific documentation requirements in addition to the above can be supplied at extra cost.

10 Maintenance of qualified actuators

Rotork is responsible for the generic and specific qualification of safety related actuators up to the expiry of the warranty period. Any modifications required as a result of changes in customer specification may necessitate retesting of the actuators by qualified personnel and test equipment for the qualification documentation to be maintained. Similarly, repairs arising from transit or site damage to components likely to affect performance may also involve retesting to enable qualification to be maintained.

Any repairs under warranty will be carried out by Rotork using only qualified personnel with the appropriate documentation and certificate of compliance; where retesting is required to maintain this qualification, Rotork will undertake this.

From expiry of the warranty period, responsibility for the equipment, including maintenance of the qualification if required, passes to the owner. Rotork can provide qualified service engineers for site work, and can also provide training courses for customer personnel.

See also:

Publication E260E - Maintenance manual for Rotork NA1 electric actuators for nuclear power plants.

11 Actuators for non-safety related duties outside containment

11 Actuators for non-safety related duties outside containment

Seismic class motor operated valves for which actuator function is not required during accident conditions do not need type NA actuators if they are outside the containment and under normal ambient conditions.

Because the stressed components of the actuator for part of the valve structure, however, seismic qualification of the valve incorporating the actuator is required, and the appropriate data is available for standard SyncroSet actuators, which may be used up to vibration limits of 0.75g, 0.2-34Hz applied at the mounting flange.



12 Conventional valve duties

12 Conventional valve duties

The majority of motorized valves in nuclear power stations come under this category, and attention is drawn to the very considerable advantages in terms of simplicity and economy in engineering, procurement, installation and wiring afforded by Rotork SyncroPak actuators with their environmentally sealed integral starter package (Figure 12.1). In addition, SyncroPak diagrams provide every facility for supervisory and computer control (Figure 12.2) - see Publication E262E.

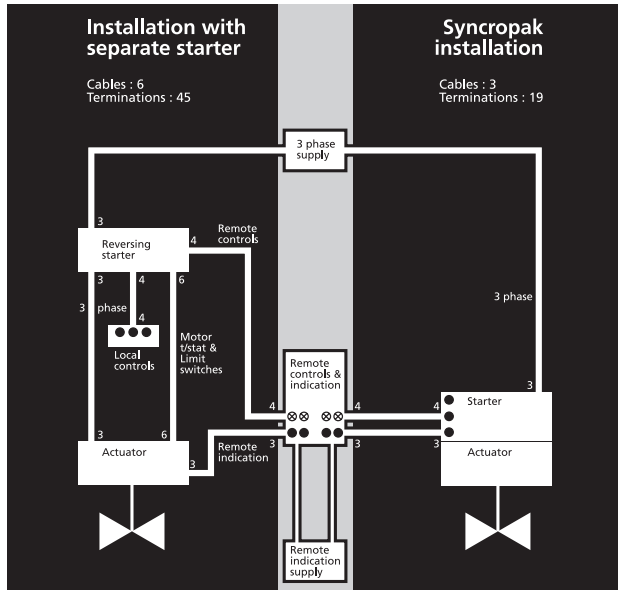

Fig.12.1 Comparison of motorised valve installations with SyncroPak and separate starter

Valve motorized with Rotork IQ/A Range SyncroPak

Summary of Fault diagnosis and Supervisory facilities of SyncroPak

<p>1. Before remote operation</p> <p>A Is the 3 phase power available? Is the rotation correct? Is the control supply available?</p> <p>B Is the Local/Remote switch set to Remote? Is the valve still in the position last set by remote control?</p>	<p>YES</p> <p>Available for Remote Control</p>		Remote Control System
<p>2. During remote operation</p> <p>C Are power and control supplies still available? Motor not overheating</p> <p>D Have contactors responded to control signal?</p> <p>E Has the valve unseated?</p> <p>F Is valve free of obstruction?</p> <p>G Has valve reached exact end of travel, with motor switch off?</p>	<p>YES</p> <p>Operation completed</p>		Remote Control System
<p>3. After remote operation</p> <p>A Is the 3 phase power available? Is phase rotation correct? Is the control supply available? Is the Local/Remote switch set to Remote?</p> <p>B Is the valve still in the position last set by remote control?</p>	<p>YES</p> <p>Available for Remote Control</p>		Remote Control System

Figure 12.2 Summary of supervisory facilities of SyncroPak.

13 Ordering Information

The following information must be given to Rotork to enable a bid to be made and an order to be processed for Nuclear actuators.

1 General

- 1 Project details (title, utility, NSSS supplier, contractor).
- 2 Reactor type.
- 3 Supply voltage and frequency.
- 4 Reduced voltage and frequency operating condition, if any, and for how long.
- 5 Environmental conditions, normal and abnormal (ambient temperature and pressure, radiation, seismic).
- 6 Actuator - general specification details and paint finish.
- 7 Approximate delivery required.
- 8 Documentation requirements.

2 For each Valve/Actuator

- 1 Type of Valve.
- 2 Valve stem details (diameter and lead).
- 3 Valve Stroke or Turns for full travel.
- 4 Valve Torque and Thrust requirements.
- 5 Location in Plant (inside or Outside reactor Containment).
- 6 Is valve on Safety Related duty. If so, is it active or passive (passive) or is it non-Safety Related.
- 7 Seismic Category (active or passive).
- 8 Operating time.
- 9 Safety function.

See also:

Publication E210E - 'A' Range valve actuators.

Publication E110E - 'IQ and IQT' Range valve actuators.



Electric Actuators and Control Systems
Fluid Power Actuators and Control Systems
Gearboxes and Gear Operators
Projects, Services and Retrofit

UK

Rotork plc
tel +44 (0)1225 733200
fax +44 (0)1225 333467
email mail@rotork.com

USA

Rotork Controls Inc.
tel +1 (585) 247 2304
fax +1 (585) 247 2308
email info@rotork.com

A full listing of our worldwide sales and service network is available on our website.

www.rotork.com