



Keeping the World Flowing  
for Future Generations

## IS Multi-turn Gearbox Series

The IS series of multi-turn operators has been designed with customer stocking in mind, and features a removable output sleeve to facilitate spindle machining.

Operating temperature normally ranges from -40 to 250 °F, although other temperature ranges are available on request.

Standard input (for actuation) and output flanges are to MSS SP-102. However, equivalent standards such as ISO can be supplied.

### Application

Rotork IS series operators are multi-turn devices intended for the operation of gate, globe, sluice and penstock valves. The gearboxes are suitable for manual and motorised applications.

### Environmental Specification

Enclosure IP67 standard suitable for submerged duty up to a depth of 3 feet for 30 minutes.

Enclosure IP68 continuous submerged duty up to a maximum depth of 50 feet.

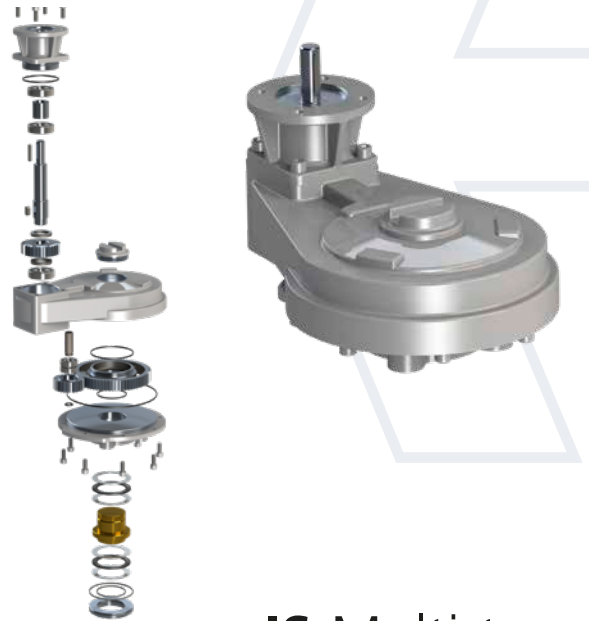

## IS Multi-turn Cast Iron Housing Gearboxes

### Features

- Totally enclosed gearing
- Grease filled for life and fully sealed
- Comprehensive gear ratios
- Removable output sleeve
- Spur and bevel combinations available
- Input gear mounted on ball bearings

### Options

- Upward or downward oriented input
- Auxiliary spur/bevel input reducers
- Input flanges for motorisation
- Two speed spur input reducers
- High and low temperatures
- Padlockable handwheels
- Nuclear
- IP68
- Buried duty
- Raw sewage
- Mechanical dial position Indicator
- Flexible extensions
- Firesafe to ISO 10497
- Interlock safety system

## IS Multi-turn Cast Iron Housing Gearboxes

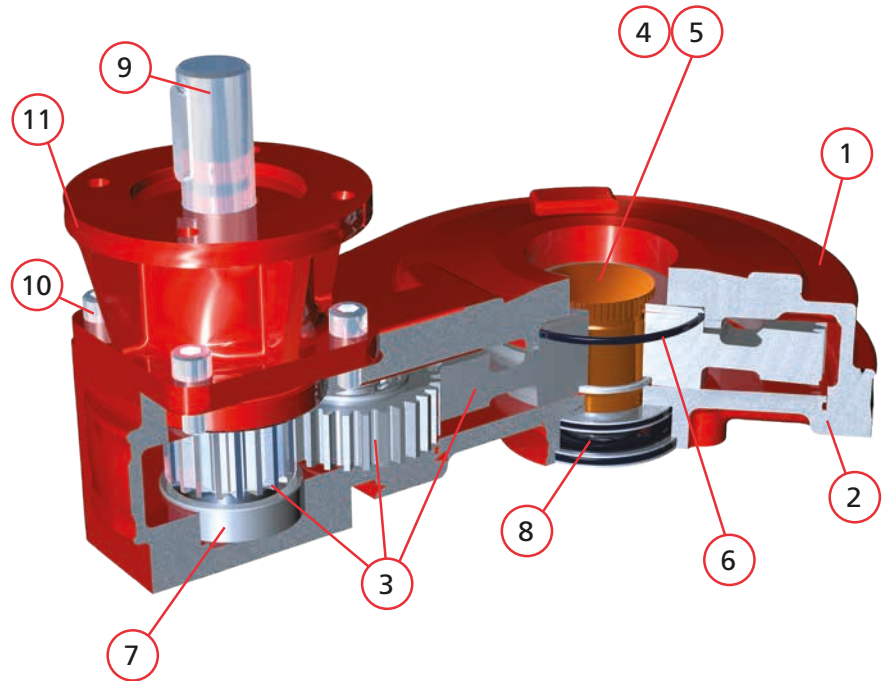

### Material Specification for Rotork IS Range of SPUR Gear Valve Operators

No.	Description	Material	USA Standard
1	Gearcase (IS2 to IS7, IS12 & IS13)	Cast Iron	ASTM A48 35B/40B
	Gearcase (IS8 to IS11 & IS15 to IS20)	SG Iron	ASTM A536 65-45-12
2	Baseplate	SG Iron	ASTM A536 65-45-12
3	Gears	SG Iron	AISI/SAE 1010 or 4340
		Steel	
4	Output Sleeve Form B	Steel	ASIS/SAE 1023
5	Output Sleeve Form A	Aluminium Bronze	ASTM B505 C95800
6	Seals	Nitrile Rubber	
7	Input Shaft bearings	Ball Bearings	
8	Output Thrust Bearings	Needle Roller Bearings (with the exception of output sizes 14, 16, 18, 19 & 20 which has Roller Thrust Bearings)	
9	Input Shaft	Steel	AISI/SAE 4340
10	Fasteners	Steel	
11	Input Housing	Cast Iron	ASTM A48 35B/40B
	Grease	Renolit CL-X2	
	Finish	PE3 Grey Primer (other finishes available on request)	

Note: Because of the company's policy of continuous improvement, Rotork reserves the right to change specification details without prior notice.

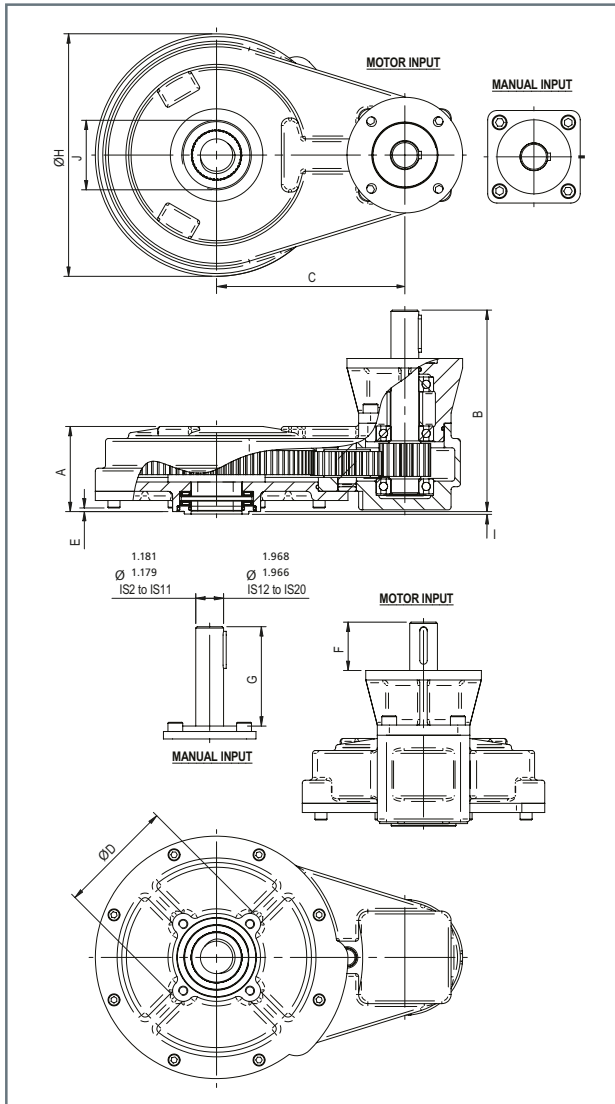

### Input Flange Details

Input	Flange Dia. & Thickness	Shaft Dia.	Key Details
F10 & FA10	Ø4.92 x 0.39	0.787 - 0.002	0.236 x 0.236 x 1.575
F14 & FA14	Ø6.89 x 0.59	1.181 - 0.002	0.315 x 0.276 x 1.575
F16 & FA16	Ø8.27 x 0.79	*1.575 - 0.002	**0.472 x 0.315 x 2.165
F25 & FA25	Ø11.18 x 0.79	1.968 - 0.002	0.551 x 0.354 x 2.165
F30	Ø13.78 x 0.79	1.968 - 0.002	0.551 x 0.354 x 3.150
ROTORK G30	Ø16.46 x 0.79	1.968 - 0.002	0.551 x 0.354 x 3.150

\* 1.181 for IS6 & IS7.

\*\* 0.315 x 0.276 x 1.575 for IS6 & IS7.

Gearbox	Max Bore ANSI B17.1		Max Acme Thread		Weight (lbs)
	Square	Rectangle	(Inch)	(mm)	
IS2	1.5	1.625	1 3/4	45	42
IS3	1.875	2	2 1/8	55	44
IS4	1.5	1.625	1 3/4	45	55
IS5	1.875	2	2 1/8	55	66
IS6	1.875	2	2 1/8	55	99
IS7	2.5	2.625	2 7/8	73	110
IS8	2.5	2.625	2 7/8	73	165
IS9	2.75	3	3 3/8	86	181
IS10	2.75	3	3 3/8	86	238
IS11	3.5	3.75	3 7/8	100	269
IS12	3.5	3.75	3 7/8	100	408
IS13	4.5	4.625	5	127	485
IS15	4.5	4.625	5	127	595 (F35), 672 (F40)
*IS16	4.625	5	5 7/8	150	882
IS17	4.5	4.625	5	127	1182
*IS18	4.625	5	5 7/8	150	1451
**IS19	6.125	6.5	7 3/8	190	1338 (F40), 1684 (F48)
***IS20	7.5	7.75	8 3/4	225	1642 (F48), 2161 (F60)
****IS21	7.5	7.75	8 3/4	225	2319

Aluminum output sleeve supplied with cast pilot bore as standard.

Cast bores \*Ø2.36 or optional Ø1.57, \*\*\*Ø3.54 or optional Ø1.97 and \*\*\*\*Ø3.94. \*\*Machined bore Ø2.95 or optional Ø2.44.

Gearbox	Ratio	A	B	C	ØD	E	F	G	ØH	I	J	Input Options	Output Options
IS2	1, 2 & 3:1	3.43	8.70	6.02	4.92	-0.20	2.01	4.45	6.77	0.12	2.5 BSP or NPT	FA10 & FA14	FA10
IS3	1, 2 & 3:1	4.29	9.06	6.02	6.77	0.67	2.01	4.45	6.77	0.16	2.5 BSP or NPT	FA10 & FA14	FA14
IS4	2, 3, 4 & 6:1	3.62	8.70	8.03	4.92	0.16	2.01	4.45	10.31	0.12	2.5 BSP or NPT	FA10 & FA14	FA10
IS5	2, 3, 4 & 6:1	4.53	9.41	8.03	6.89	1.06	2.01	4.45	10.31	0.16	2.5 BSP or NPT	FA10 & FA14	FA14
IS6	2, 3, 4, 6 & 8:1	4.69	9.25	12.00	6.54	0.16	2.01	4.45	12.99	0.16	3.5 BSP or NPT	FA10, FA14 & FA16	FA14
IS7	2, 3, 4, 6 & 8:1	4.79	9.29	12.00	7.87	0.20	2.01	4.45	12.99	0.19	3.5 BSP or NPT	FA10, FA14 & FA16	FA16
IS8	4, 6, 8, 10, 12 & 15:1	7.20	13.50	13.11	8.27	1.50	2.36	6.10	12.99	0.19	4 BSP or NPT	FA10, FA14, FA16 & FA25	FA16
IS9	4, 6, 8, 10, 12 & 15:1	7.44	13.74	13.11	11.81	1.73	2.36	6.10	12.99	0.19	4 BSP or NPT	FA10, FA14, FA16 & FA25	FA25
IS10	4, 6, 8, 10, 12 & 15:1	8.70	14.80	14.02	11.81	1.61	2.36	6.10	16.22	0.19	5 BSP or NPT	FA14, FA16 & FA25	FA25
IS11	4, 6, 8, 10, 12 & 15:1	9.53	15.63	14.02	13.78	2.44	2.36	6.10	16.22	0.19	5 BSP or NPT	FA14, FA16 & FA25	FA30
IS12	8, 10, 12 & 15:1	11.10	17.20	16.02	13.78	2.44	2.36	6.10	16.22	0.19	Ø7.7 Bore (4 x M10 on 8.7 PCD)	FA14, FA16 & FA25	FA30
IS13	8, 10, 12 & 15:1	11.73	17.83	16.02	16.14	3.07	2.36	6.10	20.47	0.19	Ø7.7 Bore (4 x M10 on 8.7 PCD)	FA14, FA16 & FA25	FA35
IS15	10, 12 & 15:1	16.26	22.20	17.87	16.14	2.83	2.36	6.10	20.47	0.19/0.32	Ø7.7 Bore (4 x M10 on 8.7 PCD)	FA14, FA16 & FA25	FA35, FA40
IS16	10, 12 & 15:1	20.67	26.61	17.87	18.74	7.24	2.36	6.10	20.47	0.32	Ø7.7 Bore (4 x M10 on 8.7 PCD)	FA14, FA16 & FA25	FA40
IS17	15 & 24:1	19.02	26.10	24.02	16.14	2.83	3.54	7.28	27.76	0.19	Ø8.7 Bore (4 x M10 on 10.4 PCD)	FA16, FA25, FA30 & FA35	FA35
IS18	15 & 24:1	23.43	30.51	24.02	18.74	7.24	3.54	7.28	27.76	0.32	Ø8.7 Bore (4 x M10 on 10.4 PCD)	FA16, FA25, FA30 & FA35	FA40
IS19	15 & 24:1	25.47	32.56	24.02	18.74	9.29	3.54	7.28	27.76	0.32	Ø8.7 Bore (4 x M10 on 10.4 PCD)	FA16, FA25, FA30 & FA35	FA40, FA48
IS20	15 & 24:1	27.95	35.04	24.02	21.85	11.77	3.54	7.28	27.76	0.32	Ø9.6 Bore (4 x M10 on 11 PCD)	FA16, FA25, FA30 & FA35	FA48, FA60
IS21	15 & 24:1	30.71	37.80	24.02	TBC	14.53	3.54	7.28	27.76	0.32	Ø9.6 Bore (4 x M10 on 11 PCD)	FA16, FA25, FA30 & FA35	FA60

All dimensions in inches.

### Gearbox Selection Chart

Gearbox	Nominal Ratio					Exact Ratio					Manual Output Torque (ft-lb)	Max Manual Thrust (lb x 1000)	Motorised Output Torque (ft-lb)	Max Motorised Thrust (lb x 1000)	Mechanical Advantage ±10%*							
	1	2	3	6	8	1.25	2.04	3.00	6.00	8.00					1.125	1.830	2.700	5.400	7.200			
IS2	1	2	3			1.25	2.04	3.00			375	12	300	12	1.125	1.830	2.700					
IS3	1	2	3			1.25	2.04	3.00			375	40	300	40	1.125	1.830	2.700					
IS4	2	3	4	6		2.12	3.00	4.10	6.00		625	12	500	12	1.900	2.700	3.690	5.400				
IS5	2	3	4	6		2.12	3.00	4.10	6.00		625	40	500	40	1.900	2.700	3.690	5.400				
IS6	2	3	4	6	8	2.00	3.00	4.00	6.00	8.00	1250	40	1000	40	1.800	2.700	3.600	5.400	7.200			
IS7	2	3	4	6	8	2.00	3.00	4.00	6.00	8.00	1250	80	1000	60	1.800	2.700	3.600	5.400	7.200			
IS8	4	6	8	10	12	15	4.01	6.10	7.95	10.20	12.26	15.03	1875	80	1500	60	3.600	5.490	7.156	9.180	11.030	13.520
IS9	4	6	8	10	12	15	4.01	6.10	7.95	10.20	12.26	15.03	1875	100	1500	80	3.600	5.490	7.156	9.180	11.030	13.520
IS10	4	6	8	10	12	15	4.04	6.11	7.81	10.17	12.11	14.66	4000	100	3000	80	3.633	5.500	7.025	9.156	10.900	13.194
IS11	4	6	8	10	12	15	4.04	6.11	7.81	10.17	12.11	14.66	4000	150	3000	112.5	3.633	5.500	7.025	9.156	10.900	13.194
IS12	8	10	12	15		8.09	9.99	11.83	15.15		8000	150	6000	112.5	7.280	8.993	10.649	13.632				
IS13	8	10	12	15		8.09	9.99	11.83	15.15		8000	250	6000	187.5	7.280	8.993	10.649	13.632				
IS15	10	12	15			9.86	12.00	15.00			14000	250	12000	187.5	8.870	10.800	13.500					
IS16	10	12	15			9.86	12.00	15.00			14000	350	12000	296.75	8.870	10.800	13.500					
IS17	15	24				15.17	24.09				34000	250	32000	187.5	13.650	21.680						
IS18	15	24				15.17	24.09				34000	350	32000	296.75	13.650	21.680						
IS19	15	24				15.17	24.09				34000	500	32000	375	13.650	21.680						
IS20	15	24				15.17	24.09				34000	750	32000	500	13.650	21.680						
IS21	15	24				15.17	24.09				34000	975	32000	650	13.650	21.680						

For manual torque the static safety factor is 1.5. For motorised torque the static safety factor is 2. \*The published M.A. is achieved after a few cycles.

### Dimensions

Type	ØH	K	N
F200	8	2.97	3
F300	12	3.96	3
F400	16	3.96	4
F500	20	3.96	4
F600	24	3.96	4
F700	28	3.96	6
F800	32	3.96	6
F900	36	3.96	6
F1000	40	3.96	6
F1100	44	3.96	6
F1200	48	3.96	8

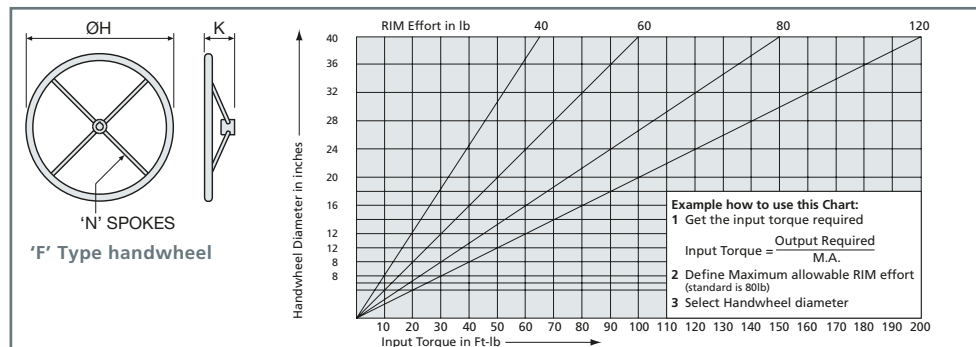

A full listing of the Rotork sales and service network is available on our website.

[www.rotork.com](http://www.rotork.com)

**Headquarters**  
Rotork Gears UK  
tel +44 (0)113 2567922  
email sales@rotorkgears.com

**Corporate Headquarters**  
Rotork plc  
tel +44 (0)1225 733200  
email mail@rotork.com

**rotork®**

Electric Actuators and Control Systems  
Fluid Power Actuators and Control Systems  
Gearboxes and Gear Operators  
Precision Control and Indication  
Projects, Services and Retrofit