

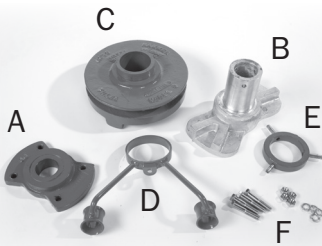

Installation Instructions

M Series *Hammer Blow Impact Actuator* *Chain Wheel*

Model: Direct Mount



Parts:

- A. Adapter Plate
- B. Anvil
- C. Hammer
- D. Chain Guide
- E. Set Collar
with Roll Pins
- F. Nuts and Bolts

Procedure:

- ① Remove existing valve handwheel and replace with Adapter Plate (A).
IMPORTANT: If a Set Screw is not provided in the existing handwheel retaining nut, such provision should be made to eliminate any possibility of the retaining nut backing off the stem.
- ② Install the Anvil (B) by bolting it securely to the Adapter Plate. Once the Anvil is in place, install the Hammer (C) then the Chain Guide (D) (Chain wheel models only). Complete the assembly by attaching the Set Collar (E).
- ③ **Chain wheel Models**
When installing, match the Roll Pins in the Set Collar to the holes drilled in the Anvil. Drive the Roll Pins in the Collar in to the matching holes in the Anvil. This step is the same for both chain and handwheel models.

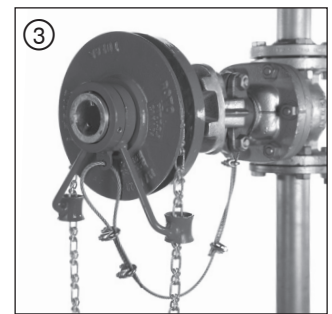
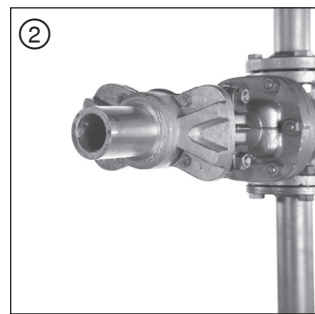
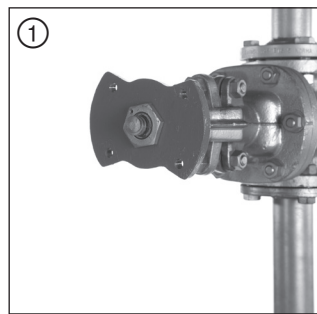

Caution:

Chain wheel **MUST** be installed properly for safe operation. Follow **ALL** Installation instructions carefully.

NEVER install an M-Series Impact Operation on **ANY** make, model or type of **GEAR OPERATED** valve.

To eliminate any possibility of the valve handwheel retaining nut backing off the stem, **IT MUST HAVE A SET SCREW IN PLACE.**

EVERY Impact Operator must be scheduled for **REGULAR, PERIODIC inspection and maintenance.**

Roto Hammer **STRONGLY RECOMMENDS** that **EVERY** overhead Impact Operator be fitted with a **Roto Hammer RCK Safety Cable Kit** (available from your local distributor or from Roto Hammer Industries).

Set screws and other threaded fasteners **MUST** be secure and tight.

(See other side for
Clamp-On Installation
Instructions)

