



Installation Instructions

C Series Chain Wheels

Models:

C9, C12, C15, C18, C30 & C40

Parts:

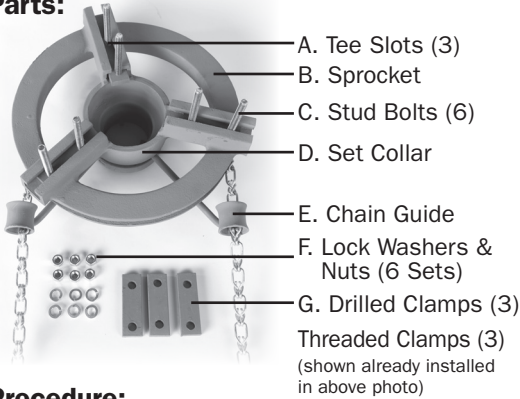

Completed Assembly:

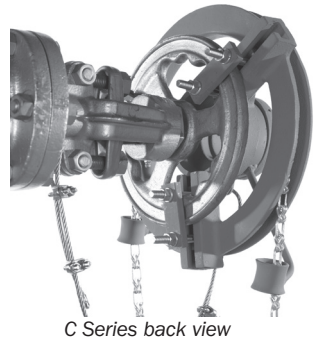

Procedure:

- ① Screw all six Stud Bolts (C) into the Threaded Clamps (G).
- ② Slide the three clamps (with bolts) into the three Tee Slots (A) and slightly tighten the bolts against the bottom of the tee slots just enough to hold them in place. Do Not Over Tighten.
- ③ Center the chain wheel over the valve handwheel.
- ④ Slide the Stud Bolts over the rim of the handwheel and install the Threaded Clamps and Lock Washers & Nuts (F). Securely tighten all six nuts.

Caution:

- ① Whenever a chain wheel is installed, provision must be made to KEEP THE VALVE HANDWHEEL RETAINING NUT FROM BACKING OFF THE STEM. This best done by installing a SET SCREW that secures the nut to the stem.
- ② All chain wheel installations, regardless of age, must be regularly inspected as part of the user's Safety/Maintenance Procedures. Set screws and other threaded fasteners MUST be secure and tight.
- ③ As an additional safeguard, Roto Hammer strongly recommends that ALL chain wheels be fitted with an appropriately sized Roto Hammer RCK Safety Cable Kit available from your local distributor or Roto Hammer Industries.

See other side for Instructions for E Series Chain Wheels



Rotork plc, Bath, UK
tel: +44 (0)1225 733200 email: mail@rotork.com
Rotork, Winston-Salem, USA
tel: +1 (336) 659 3400 email: US-WS-CS@rotork.com