

INPUT FLANGE DETAILS							MOUNTING HOLES - BOLT CIRCLE (OFF CENTRES)								
INPUT FLANGE	FLANGE O/DIA. + THICKNESS	SHAFT DIA.	RECESS DIA.	RECESS DEPTH	HOLE DETAILS (45° OFF CENTRES)	KEY DETAILS	ISO 5211 / MSS SP-101 MOUNTING OPTION	HOLE DETAILS (45° OFF CENTRES)	STANDARD	MIN BORE	SQ KEY MAX BORE	SQ KEY SIZE	RECT. KEY MAX BORE	RECT. KEY SIZE	SQ BORE MAX
ISO F10	Ø125 x 10 (Ø4.92" x 0.38")	Ø20.00-0.05 (Ø0.787"-0.002")	Ø70.05+0.15 (Ø2.758"+0.006")	4 (0.16")	4 x Ø10.5 ON Ø102.0 P.C. (4 x Ø0.41" ON Ø4.02" P.C.)	6x6x40 (0.24"x0.24"x1.57")	ISO F16*	4 x M20 x 20 (0.79") DEEP ON Ø165.0 (Ø6.50") P.C.	BS4235	-	-	-	76.0	22 x 14	□ 62.0 (2.44")
FA10			BS46						-	2.75"	3/4" SQ.	3.00"	3/4" x 1/2"		
	ANSI B17.1	-	2.75"	5/8" SQ.	3.00"	3/4" x 1/2"									
			Ø58.70+0.15 (Ø2.311"+0.006")				FA16*	4 x 3/4" UNC x 20 (0.79") DEEP ON Ø165.0 (Ø6.50") P.C.	DIN 6885	-	-	-	76.0	22 x 14	

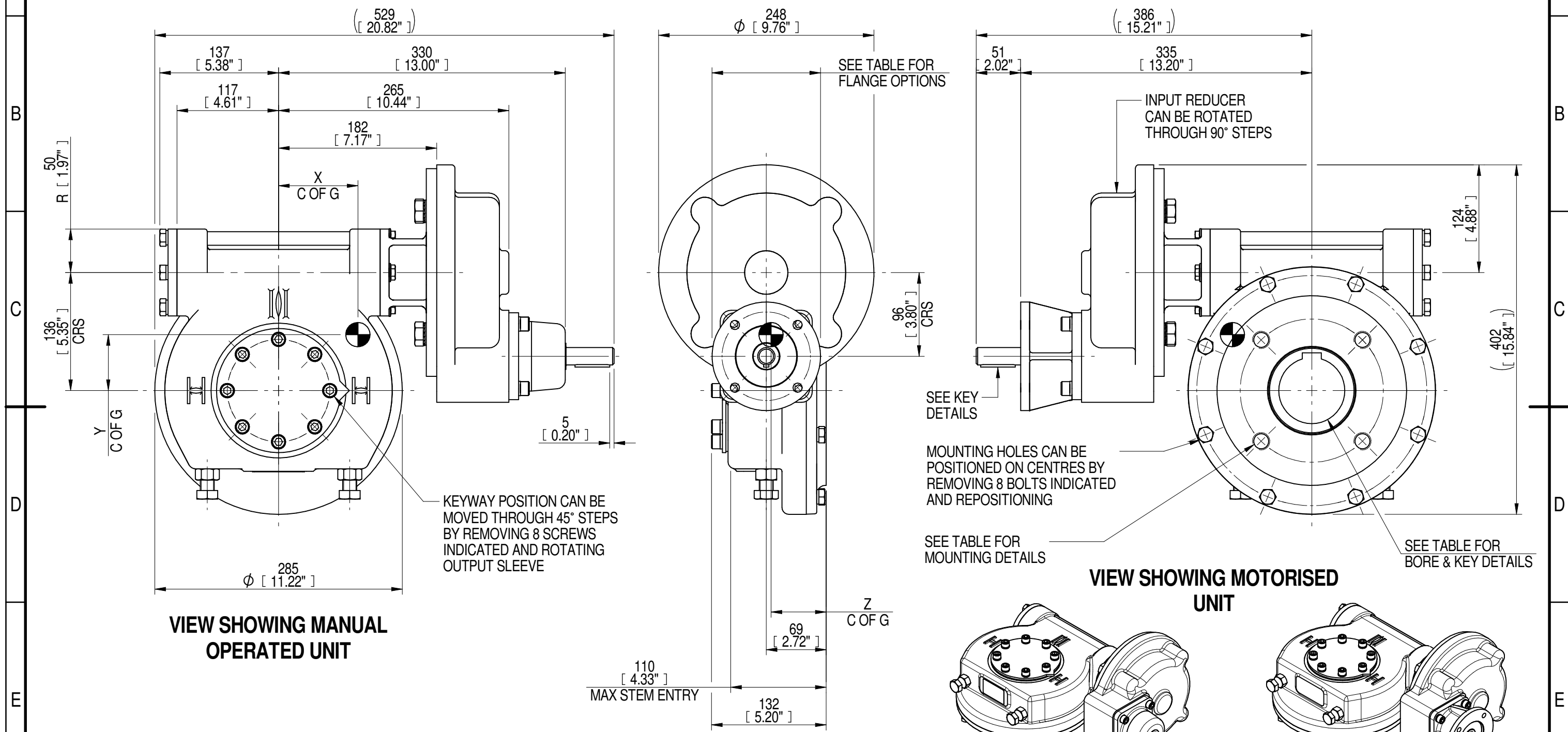

PLAN VIEW OF GEARBOX IN CLOSED POSITION SHOWING STANDARD KEYWAY POSITIONS. ALTERNATIVES AVAILABLE ON REQUEST

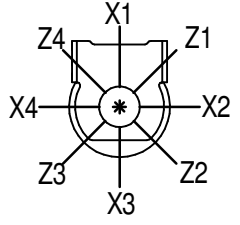

NOTES:  
 1. \* THREAD DEPTH DOES NOT MATCH ISO STANDARD  
 2. CENTRE OF GRAVITY POSITION IS INDICATIVE FOR STANDARD BUILD WHEN IN POSITION SHOWN

RATIO	TURNS TO CLOSE	M.A. ± 10%	WEIGHT (Kg)	MAX OUTPUT (Nm)	MAX INPUT (Nm)	X	Y	Z
240	60	97	62	5334	55	92	65	64
200	50	81	62	5334	66	91	64	64
DESCRIPTION				TORQUE		CENTRE OF GRAVITY		

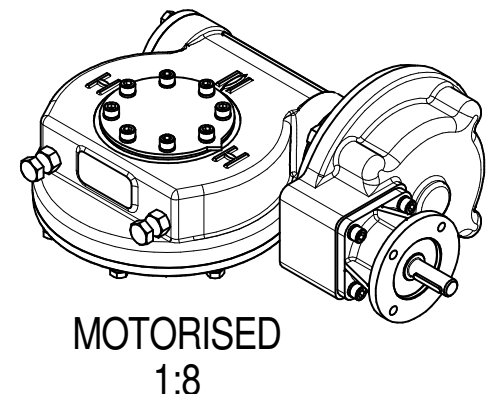
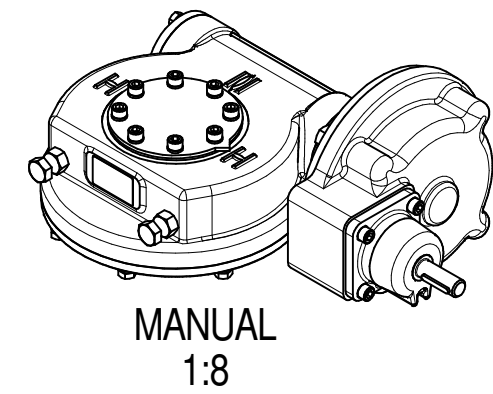

AS PART OF CONTINUOUS PRODUCT DEVELOPMENT, ALL DETAILS SUBJECT TO CHANGE WITHOUT PRIOR NOTICE. FOR UP TO DATE DETAILS PLEASE VISIT [www.rotork.com](http://www.rotork.com)

**rotork** Gears  
LEEDS - UK  
[www.rotork.com](http://www.rotork.com)

This drawing is confidential and is the property of Rotork Gears and must not be reproduced either wholly or partly. All rights in respect of patents, designs and copyrights are reserved. ©2016

Document Type **PUBLICITY**  
Dimensions in mm

Title  
**IW/MOW52 QUARTER TURN GEARBOX, 200/240 ; 1, MANUAL F10/ FA10 INPUT : F16/ FA16 OUTPUT**

Drawing Number  
**PUB-IW52FBIRL-F10-F16**

Sheet 1 of 1 | Size A3