

INPUT FLANGE DETAILS				MOUNTING HOLES - BOLT CIRCLE (OFF CENTRES)				STEM ACCEPTANCE IN ACCORDANCE TO STANDARD							
INPUT FLANGE	FLANGE O/DIA.	HOLE DETAILS (OFF CENTRES)	KEY DETAILS	ISO 5211 / MSS SP-101 MOUNTING OPTION	HOLE DETAILS (OFF CENTRES)	MAX OUTSIDE DIA. INCLUDING DRILLED HOLES	MIN INSIDE DIA. INCLUDING DRILLED HOLES	STANDARD	MIN BORE	SQ KEY MAX BORE	SQ KEY SIZE	RECT. KEY MAX BORE	RECT KEY SIZE	SQ BORE MAX	
F10	Ø125 (Ø4.92")	4x Ø11 ON A Ø102P.C. (4x Ø0.43" ON A Ø4.02"P.C.)	6x6x36 (0.24"x0.24"x1.42")	F07 (FA07)	4x M8 x 13 DEEP ON A Ø70P.C. (4x 5/16"UNC x 0.51" DEEP ON A Ø2.75"P.C.)	Ø156 (Ø6.14")	Ø62 (Ø2.44")	BS4235	-	-	-	-	-	-	-
				F10 (FA10)	4x M10* x 13 DEEP ON A Ø102P.C. (4x 3/8"UNC x 0.51" DEEP ON A Ø4"P.C.)			BS46	-	-	-	-	-	-	
				F12 (FA12)	4x M12* x 16 DEEP ON A Ø125P.C. (4x 1/2"UNC x 0.63" DEEP ON A 4.95"P.C.)			ANSI B17.1	Ø0.63"	Ø1.77"	-	-	-	□ 1.5"	
				F14 (FA14)	4x M16* x 18 DEEP ON A Ø140P.C. (4x 5/8"UNC x 0.71" DEEP ON A Ø5.5"P.C.)			DIN 6885	Ø16	Ø45	-	-	-	□ 38	

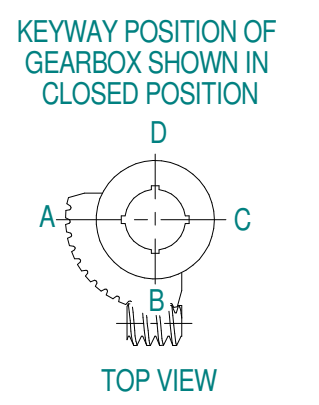
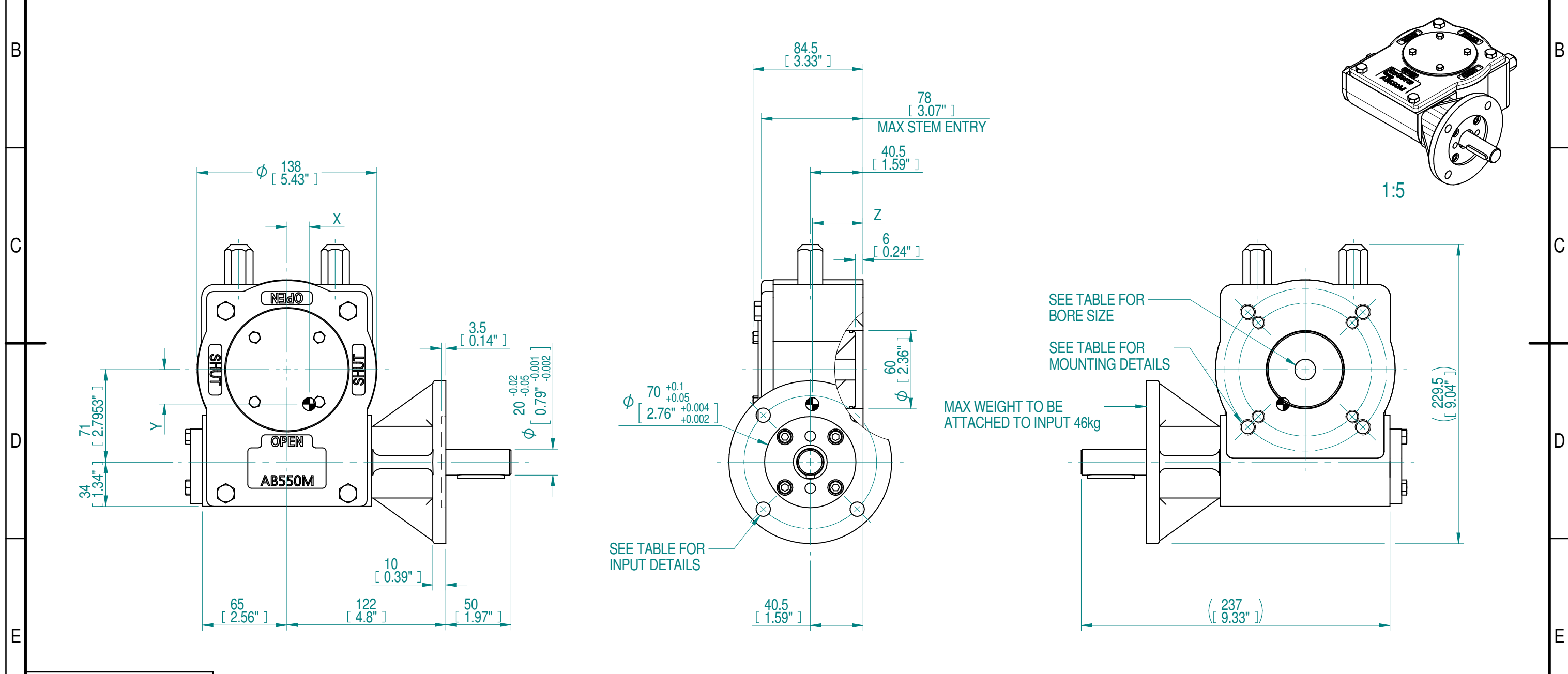

NOTES:
1. * THREAD DEPTH DOES NOT MATCH ISO STANDARD

DESCRIPTION	TORQUE	CENTRE OF GRAVITY
RATIO	MAX OUTPUT	X
34:1	600Nm	17.1
8.5	5310 lbf.in.	26.4
TURNS TO CLOSE	MAX INPUT	39
12 ± 15%	443lbf.in.	1.54"
M.A.	WEIGHT	
	11.9 kg	
	26.18 lbs.	

AS PART OF CONTINUOUS PRODUCT DEVELOPMENT, ALL DETAILS SUBJECT TO CHANGE WITHOUT PRIOR NOTICE. FOR UP TO DATE DETAILS PLEASE VISIT www.rotork.com

rotork Gears
LEEDS - UK
www.rotork.com

This drawing is confidential and is the property of Rotork Gears and must not be reproduced either wholly or partly. All rights in respect of patents, designs and copyrights are reserved. © 2015

Document Type	DETAIL DRAWINGS	Title	GEARBOX AB550 MOTORISED FOR BURRIED DUTY LEFT HANDED
Created	M JONES	26-2-2016	Drawing Number
Checked	T WITAMORE	30-3-2015	AB550M BUR LH
Approved			Sheet 1 of 1 Size A3